

blyweert[®]
aluminium
exactly your profile

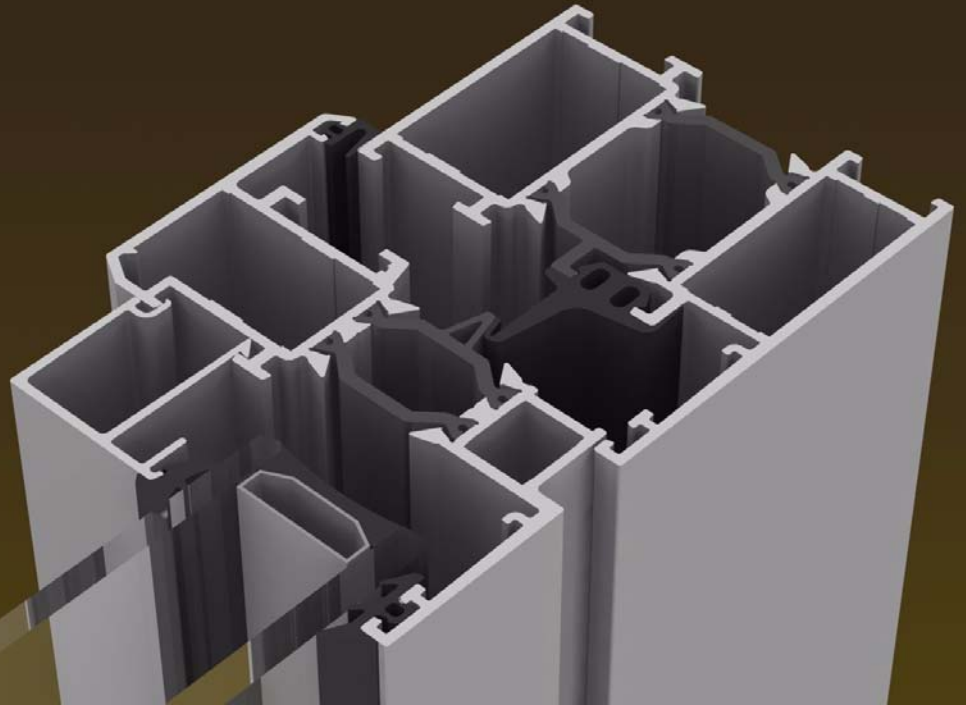

Hercules P02

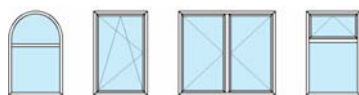

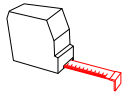

Lengte (mm)
Longueur (mm)
Length (mm)

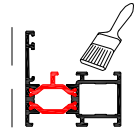

Omtrek
Périmètre
Perimeter



Kleur
Couleur
Color

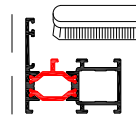

Borstel-omtrek
Périmètre brossage
Perimeter of brushing

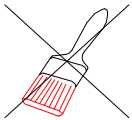

Brut
Brut
Mill finish



Pershoek
Équerre sertir
Clamping corner



Zwart
Noir
Black



Schroefhoek
Équerre à visser
Square coupling joint



Wit
Blanc
White



T-verbinding
Attacher traverse
Connection for transom



RAL
RAL
RAL



Variabele hoekverbinding
Équerre à angle variable
Adjustable connecting component



Pagina
Page
Page



Primaire zichtzijde
Surface primaire
Primary surface



Toepassing
Application
Application



Secundaire zichtzijde
Surface secondaire
Secondary surface

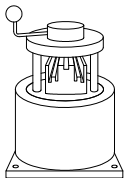

Kapmatrijs
Poinçonneuse
Punch tool

AN

Geanodiseerd
Anodisé
Anodised

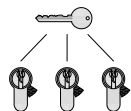

Cilinder gelijksluitend
Cylindre même fermeture
Cylinder keyed-alike

~~AN~~

Niet geanodiseerd
Pas de anodisé
not anodised

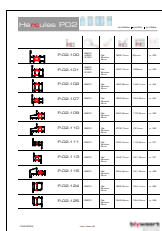

Profieloverzicht
Overview profil
Profile overview

p. 7

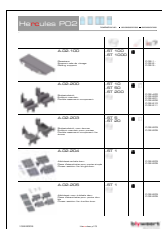

Toebehoren
Accessoires
Accessories

p. 21

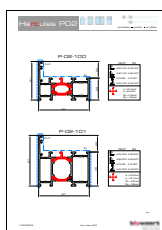

Profielen
Profils
Profiles

p. 73

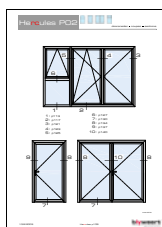

Doorsneden
Coupes
Section

p. 141

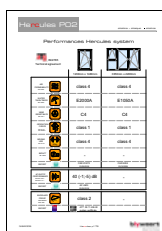

Statica
Statique
Statics

p. 209

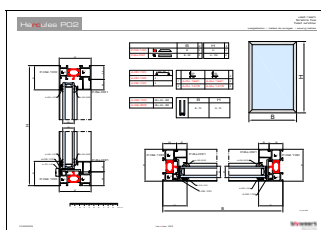

Zaagtabellen
Tables de sciages
Sawing tables

p. 219

vast raam
fenêtre fixe
fixed window

p. 219

vast raam met tussenstijl
fenêtre fixe avec traverse
fixed window with mullion

p. 220

kipraam
fenêtre basculante
tilt window

p. 222

draaikip fenêtre oscillo battante tilt and turn window	p. 223
tuimelraam chassis pivotants pivoting window	p. 224
kipschuif coulissant a translation fixed window	p. 225
stolpraam double ouvrant à la française double casement window	p. 226
samengesteld raam fenêtre composé complex window	p. 227
enkele deur naar binnen draaiend porte simple ouvrant interieur single door inside opening	p. 228
vlakke enkele deur naar binnen draaiend plat de porte simple ouvrant interieur flat single door inside opening	p. 229
enkele deur naar buiten draaiend porte simple ouvrant exterieur single door outside opening	p. 231
vlakke enkele deur naar buiten draaiend plat de porte simple ouvrant exterieur flat single door outside opening	p. 234
dubbele deur naar binnen draaiend porte double ouvrant interieur double door inside opening	p. 237
vlakke dubbele deur naar binnen draaiend plat de porte double ouvrant interieur flat double door inside opening	p. 238
dubbele deur naar buiten draaiend porte double ouvrant exterieur double door outside opening	p. 241
vlakke dubbele deur naar buiten draaiend plat de porte double ouvrant exterieur flat double door outside opening	p. 243

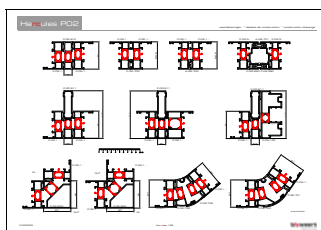





Werktekeningen Dessins de construction Construction drawings

p. 247

overzicht vue d'ensemble overview	p. 247
variabele hoek angle variable variable angle	p. 248
pershoek équerre à sertir clamping corner	p. 250
schroefhoek équerre à visser square coupling joint	p. 251

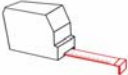
t-verbinder attacher traverse connection component for transom	p. 252
boormallen variabele schroefhoek gabarits de perçage équerre à visser variable drilling jig variable square coupling joint	p. 256
stolpeindstuk raam embout mauclair fenêtre double casement component window	p. 257
eindrubber verborgen afwateringsprofiel joint finale pour profile évacuation d'eau invisible Endgasket for invisible water outlet profile	p. 258
koppelstuk glaslat Linea raccord parclose Linea connector Glazing bead Linea	p. 259
montage rolluil assemblage volet roulant assembly rolling shutter	p. 260
plaathouder porteur de plaque plate holder	p. 261
tuimelraam chassis pivotants pivoting window	p. 262
uitfrezing kruk wentelraam A-BS-280 fraisage poignée chassis pivotants A-BS-280 milling handle pivoting window A-BS-280	p. 263
montage waterkapje A-00-100 assemblage busette A-00-100 assembly drain hole cover A-00-100	p. 264
uitfrezing raamkruk A-BS-023 / 024 / 084 - A-BF-004 / 005 / 006 fraisage poignée A-BS-023 / 024 / 084 - A-BF-004 / 005 / 006 milling handle A-BS-023 / 024 / 084 - A-BF-004 / 005 / 006	p. 265
stolpeindstuk deur embout mauclair porte double casement component door	p. 266
stolpeindstuk vlakke deur embout mauclair porte plat double casement component flat door	p. 267
connectie P-03-224 - P-03-225 connection P-03-224 - P-03-225 connection P-03-224 - P-03-225	p. 268
montage deur T-profiel assemblage porte T-profil assembly door T-profile	p. 270
sloten en bewerking binnendraaiende deur serrures et construction porte ouvrant interieur locks and construction door inside	p. 271
sloten en bewerking buitendraaiende deur serrures et construction porte ouvrant exterieur locks and construction door outside	p. 277
sloten en bewerking vlakke binnendraaiende deur serrures et construction porte plat interieur locks and construction flat door inside	p. 284
sloten en bewerking vlakke buitendraaiende deur serrures et construction porte plat exterieur locks and construction flat door outside	p. 289

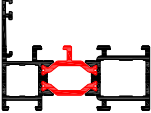
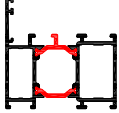
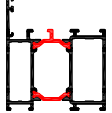
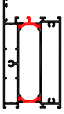
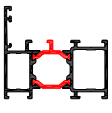
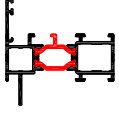
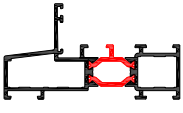
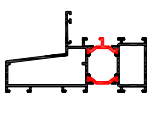
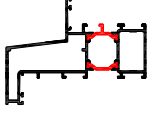
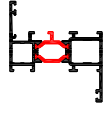
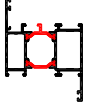

						
	P-02-100	6500 4350 2150	Ral Bicolor Brut	368.7mm	94mm	p. 73
	P-02-101	6500 4350 2150	Ral Bicolor Brut	400.7mm	126mm	p. 73
	P-02-102	6500	Ral Bicolor Brut	420.8mm	146.1mm	p. 74
	P-02-103	6500	Ral Bicolor Brut	522.8mm	246.9mm	p. 75
	P-02-104	6500	Ral Bicolor Brut	387.8mm	104.1mm	p. 74
	P-02-107	6500	Ral Bicolor Brut	393.5mm	124.6mm	p. 76
	P-02-108	6500	Ral Bicolor Brut	421mm	113.4mm	p. 76
	P-02-109	6500	Ral Bicolor Brut	520.6mm	170.6mm	p. 77
	P-02-110	6500	Ral Bicolor Brut	578.7mm	191mm	p. 78
	P-02-111	6500	Ral Bicolor Brut	430.4mm	115.5mm	p. 79
	P-02-113	6500	Ral Bicolor Brut	442.7mm	151.3mm	p. 79





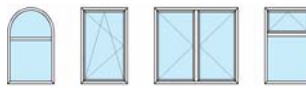

profielen ■ profils ■ profiles

Hercules P02

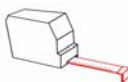
	P-02-115	6500	Ral Bicolor Brut	534.6mm	151.5mm	p. 80
	P-02-116	6500	Ral Bicolor Brut	376.9mm	93.3mm	p. 95
	P-02-124	6500	Ral Bicolor Brut	365.2mm	154.1mm	p. 81
	P-02-125	6500	Ral Bicolor Brut	345.9mm	154.3mm	p. 81
	P-02-200	6500 4350 2150	Ral Bicolor Brut	387.7mm	114.6mm	p. 82
	P-02-201	6500 4350 2150	Ral Bicolor Brut	420.1mm	146.6mm	p. 82
	P-02-202	6500	Ral Bicolor Brut	440.3mm	166.6mm	p. 83
	P-02-203	6500 4350 2150	Ral Bicolor Brut	441.4mm	175.7mm	p. 84
	P-02-205r2	6500 4350 2150	Ral Bicolor Brut	448.5mm	176.9mm	p. 85
	P-02-206	6500	Ral Bicolor Brut	467.2mm	204.7mm	p. 86
	P-02-207	6500	Ral Bicolor Brut	465mm	181.8mm	p. 86
	P-02-210	6500 4350 2150	Ral Bicolor Brut	393mm	108.9mm	p. 87

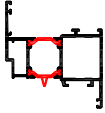
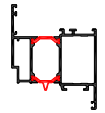
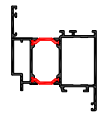
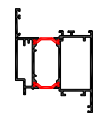
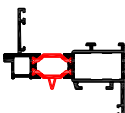
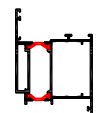
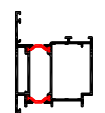
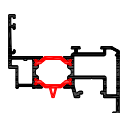
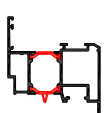
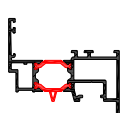
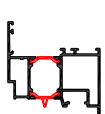
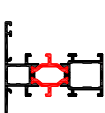

						
	P-02-211	6500 4350 2150	Ral Bicolor Brut	420.1mm	140.9mm	p. 87
	P-02-212	6500	Ral Bicolor Brut	448.3mm	164.6mm	p. 88
	P-02-213	6500	Ral Bicolor Brut	459.3mm	170mm	p. 88
	P-02-214	6500	Ral Bicolor Brut	477.5mm	204.3mm	p. 89
	P-02-220	6500	Ral Bicolor Brut	393mm	127.8mm	p. 90
	P-02-224	6500	Ral Bicolor Brut	410.8mm	172.2mm	p. 91
	P-02-225	6500	Ral Bicolor Brut	430.2mm	178mm	p. 91
	P-02-230	6500	Ral Bicolor Brut	411.5mm	122.5mm	p. 92
	P-02-231	6500	Ral Bicolor Brut	438.1mm	153.4mm	p. 94
	P-02-240	6500	Ral Bicolor Brut	429.5mm	115mm	p. 93
	P-02-241	6500	Ral Bicolor Brut	456.1mm	141.8mm	p. 93
	P-02-300	6500 4350 2150	Ral Bicolor Brut	456.8mm	118mm	p. 95







Hercules P02

profielen ■ profils ■ profiles

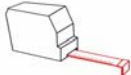
	P-02-301	6500 4350 2150	Ral Bicolor Brut	488.8mm	150mm	p. 96
	P-02-302	6500	Ral Bicolor Brut	508.8mm	170mm	p. 96
	P-02-303	6500 2150	Ral Bicolor Brut	610.8mm	272mm	p. 97
	P-02-304	6500 2150	Ral Bicolor Brut	710.8mm	372mm	p. 98
	P-02-305	6500	Ral Bicolor Brut	554mm	214.7mm	p. 99
	P-02-306	6500	Ral Bicolor Brut	532.7mm	235.7mm	p. 100
	P-02-309	6500	Ral Bicolor Brut	418.9mm	107.4mm	p. 101
	P-02-310	6500	Ral Bicolor Brut	456.8mm	118mm	p. 102
	P-02-311	6500	Ral Bicolor Brut	488.9mm	134mm	p. 102
	P-02-312	6500	Ral Bicolor Brut	508.9mm	170mm	p. 103
	P-02-313	6500	Ral Bicolor Brut	610.9mm	272mm	p. 104
	P-02-315	6500	Ral Bicolor Brut	526.3mm	187.4mm	p. 105



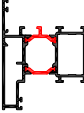
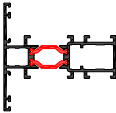
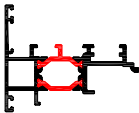
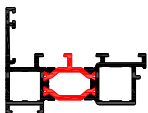
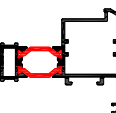
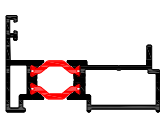
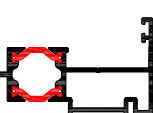
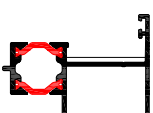
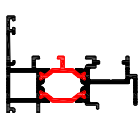
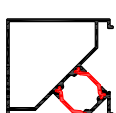
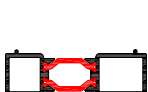
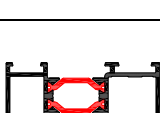







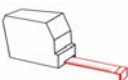

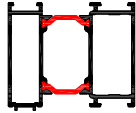

						
	P-02-319	6500	Ral Bicolor Brut	450.9mm	157.7mm	p. 101
	P-02-320	6500	Ral Bicolor Brut	442.7mm	118mm	p. 106
	P-02-400	6500 3250	Ral Bicolor Brut	420.7mm	85mm	p. 107
	P-02-404	6500	Ral Bicolor Brut	345.5mm	65mm	p. 107
	P-02-405	6500	Ral Bicolor Brut	301.3mm	116.9mm	p. 107
	P-02-424	6500	Ral Bicolor Brut	247.1mm	76.1mm	p. 108
	P-02-425	6500	Ral Bicolor Brut	246.5mm	84.8mm	p. 108
	P-02-426	6500	Ral Bicolor Brut	251.7mm	84.1mm	p. 108
	P-02-430	6500	Ral Bicolor Brut	434.2mm	84.4mm	p. 92
	P-02-500	6500	Ral Bicolor Brut	341.1mm	163.6mm	p. 109
	P-02-510	6500	Ral Bicolor Brut	189.9mm	52.8mm	p. 109
	P-02-514	6500	Ral Bicolor Brut	275.8mm	72.9mm	p. 110





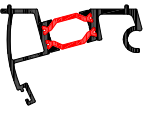
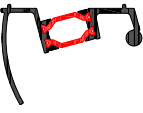
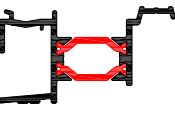
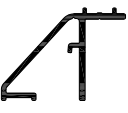

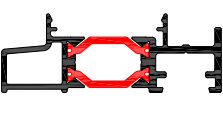



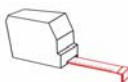

profielen ■ profils ■ profiles

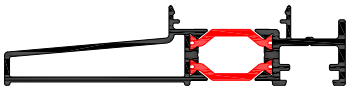
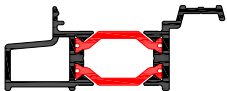
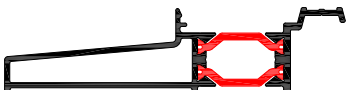
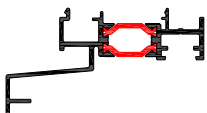
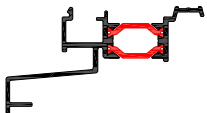
Hercules P02

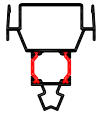
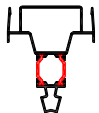
						
	P-02-515	6500	Ral Bicolor Brut	327.8mm	119.8mm	p. 110
	P-02-516	6500	Ral Bicolor Brut	429.9mm	226.4mm	p. 111
	P-02-530	6500	Ral Brut	237.7mm	22.7mm	p. 109
	P-02-535	6500	Ral Brut	105.8mm	58.3mm	p. 108
	P-02-700	6500	Ral Bicolor Brut	344.1mm	99.11mm	p. 112
	P-02-701	6500	Ral Bicolor Brut	367.2mm	103.9mm	p. 112
	P-02-702	6500	Ral Bicolor Brut	304.9mm	73.7mm	p. 112
	P-02-703	6500	Ral Bicolor Brut	313.6mm	76.1mm	p. 112
	P-02-720	6500	Ral Bicolor Brut	285.1mm	131.3mm	p. 113
	P-02-721	6500	Ral Brut	213.2mm	57.2mm	p. 113
	P-02-722	6500	Ral Brut	199.7mm	66.3mm	p. 113
	P-02-723	6500	Ral Bicolor Brut	259.5mm	61.7mm	p. 114











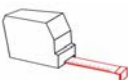







						
	P-02-724	6500	Ral Bicolor Brut	328.5mm	94.7mm	p. 114
	P-02-725	6500	Ral Bicolor Brut	192.9mm	80.8mm	p. 115
	P-02-726	6500	Ral Bicolor Brut	261.9mm	113.8mm	p. 115
	P-02-727	6500	Ral Bicolor Brut	446.6mm	245mm	p. 116
	P-02-728	6500	Ral Bicolor Brut	380mm	361mm	p. 116
	P-02-735	5500	Ral Brut	225.8mm	77.8mm	p. 117
	P-02-835	5500	Ral Bicolor Brut	406.4mm	213.3mm	p. 118
	P-02-850	5500	Ral Bicolor Brut	416.2mm	218.5mm	p. 118
	P-02-900	6500	Ral Brut	264.9mm	72.2mm	p. 119
	P-02-901	6500	Ral Brut	257.9mm	64.8mm	p. 119
	P-00-100	6500	Ral Brut	165.9mm	37.8mm	p. 120
	P-00-101	6500	Ral Brut	165.9mm	37.8mm	p. 120





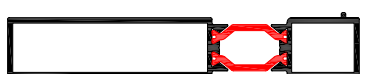





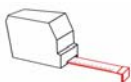







profielen ■ profils ■ profiles

Hercules P02

						
	P-00-105	6500	Ral Brut	62.2mm	19.6mm	p. 120
	P-00-106	6500	Ral Brut	109.6mm	62.2mm	p. 120
	P-00-203	6500	Ral Brut	165.9mm	34.9mm	p. 121
	P-00-204	6500	Ral Brut	110mm	26.6mm	p. 121
	P-00-205	6500	Ral Brut	79.5mm	16.7mm	p. 122
	P-00-206	6500	Ral Brut	114.7mm	26.6mm	p. 122
	P-00-207	6500	Ral Brut	123.6mm	21.3mm	p. 121
	P-00-208	6500	Ral Brut	151.7mm	30.8mm	p. 121
	P-00-500	6500 7000	Ral Brut	86.8mm	21.9mm	p. 119
	P-00-511	6500	Ral Bicolor Brut	295.8mm	295.8mm	p. 124
	P-00-512	6500	Ral Bicolor Brut	285mm	231mm	p. 124
	P-00-515	6500	Ral Brut	270mm	171.6mm	p. 124

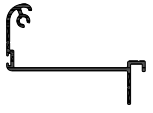









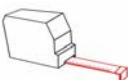







						
	P-00-601	6500	AN	51.7mm	22.5mm	p. 123
	P-00-602	6500	AN	45.1mm	17.1mm	p. 123
	P-00-610	6500	Ral Brut	55.5mm	28.6mm	p. 123
	P-00-700	6500	Brut	-	-	p. 112
	P-00-702	6500	Ral Brut	104.1mm	31.6mm	p. 112
	P-00-703	6500	Ral Brut	334.2mm	130.9mm	p. 126
	P-00-704	6500	Ral Brut	327.8mm	137mm	p. 126
	P-00-705	6500	Ral Brut	273.3mm	107.4mm	p. 126
	P-00-706	6500	Ral Brut	407.8mm	196.1mm	p. 126
	P-00-707	6500	Ral Brut	369.4mm	146.7mm	p. 126
	P-00-710	6500 5500	Ral Brut	220mm	48.6mm	p. 125
	P-00-711	6500	Ral Brut	208.7mm	42.7mm	p. 125





profielen ■ profils ■ profiles

Hercules P02

						
	P-00-720	6500	Ral Brut	204.8mm	83.9mm	p. 127
	P-00-721	6500	Ral Brut	287mm	138.5mm	p. 127
	P-00-722	6500	Ral Brut	345.9mm	168.6mm	p. 127
	P-00-723	6500	Ral Brut	406.1mm	198.7mm	p. 128
	P-00-724	6500	Ral Brut	466.3mm	228.8mm	p. 128
	P-00-725	6500	Ral Brut	526.5mm	258.9mm	p. 129
	P-00-726	6500	Ral Brut	586.8mm	289.1mm	p. 129
	P-6s-003	6500	Ral Brut	89.1mm	27.3mm	p. 130
	P-6s-007	6500	Ral Brut	108mm	31.3mm	p. 130
	P-6s-011	6500	Ral Brut	118.1mm	35.3mm	p. 130
	P-6s-013	6500	Ral Brut	122.8mm	37.3mm	p. 130
	P-6s-015	6500	Ral Brut	145.3mm	39.3mm	p. 130

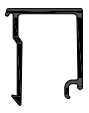

						
	P-6s-019	6500	Ral Brut	149.7mm	43.3mm	p. 130
	P-6s-021	6500	Ral Brut	150.3mm	45.3mm	p. 130
	P-6s-023	6500	Ral Brut	159.3mm	47.3mm	p. 130
	P-6s-025	6500	Ral Brut	169.8mm	47.3mm	p. 130
	P-6s-027	6500	Ral Brut	177.8mm	51.3mm	p. 130
	P-6s-029	6500	Ral Brut	178.1mm	53.3mm	p. 130
	P-6s-031	6500	Ral Brut	185.7mm	55.3mm	p. 130
	P-6s-033	6500	Ral Brut	186.1mm	57.3mm	p. 131
	P-6s-035	6500	Ral Brut	193.8mm	59.3mm	p. 131
	P-6s-037	6500	Ral Brut	193.4mm	61.3mm	p. 131
	P-6s-039	6500	Ral Brut	197.7mm	63.3mm	p. 131
	P-6s-041	6500	Ral Brut	201.4mm	65.3mm	p. 131



profielen ■ profils ■ profiles



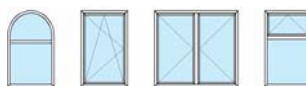

Hercules P02

						
	P-6s-043	6500	Ral Brut	205.4mm	67.3mm	p. 131
	P-6s-045	6500	Ral Brut	209.6mm	69.3mm	p. 131
	P-6s-J29	6500	Ral Brut	195mm	51.4mm	p. 132
	P-6s-J33	6500	Ral Brut	203mm	55.4mm	p. 132
	P-6b-015	6500	Ral Brut	92.3mm	39.9mm	p. 133
	P-6b-019	6500	Ral Brut	95.8mm	43.9mm	p. 133
	P-6b-021	6500	Ral Brut	98.1mm	45.9mm	p. 133
	P-6b-023	6500	Ral Brut	123.3mm	47.9mm	p. 133
	P-6b-025	6500	Ral Brut	124.7mm	49.9mm	p. 133
	P-6b-027	6500	Ral Brut	126.7mm	51.9mm	p. 133
	P-6b-029	6500	Ral Brut	128.7mm	53.9mm	p. 134
	P-6b-031	6500	Ral Brut	131.1mm	55.9mm	p. 134



						
	P-6b-033	6500	Ral Brut	134.2mm	57.9mm	p. 134
	P-6b-035	6500	Ral Brut	137mm	59.9mm	p. 134
	P-6b-037	6500	Ral Brut	141mm	61.9mm	p. 134
	P-6b-039	6500	Ral Brut	143.8mm	63.9mm	p. 135
	P-6b-042	6500	Ral Brut	149.2mm	66.9mm	p. 135
	P-6b-043	6500	Ral Brut	151mm	67.9mm	p. 135
	P-6b-045	6500	Ral Brut	154.8mm	69.9mm	p. 135
	P-6b-048	6500	Ral Brut	160.5mm	72.9mm	p. 135
	P-6f-028	6500	Ral Brut	130mm	51.1mm	p. 136
	P-6f-032	6500	Ral Brut	135.5mm	55.1mm	p. 136
	P-6f-036	6500	Ral Brut	143.5mm	59.1mm	p. 136













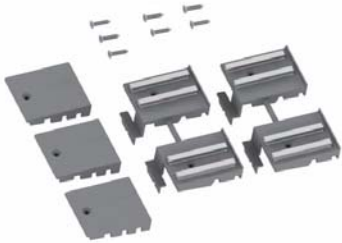





				
	<p>A-02-100</p> <p>Glassteun Support cale de vitrage Glazing support</p>	<p>-ST 100 -ST 1000</p> 	●	P-02-1.. P-02-2.. P-02-3..
	<p>A-02-101</p> <p>Glassteun P-02-207 Support cale de vitrage P-02-207 Glazing support P-02-207</p>	<p>-ST 1</p> 	●	P-02-207
	<p>A-02-200</p> <p>Stolpeindstuk Embout maclair Double-casement component</p>	<p>-ST 10 -ST 50 -ST 200</p> 	● ○	P-02-400
	<p>A-02-203</p> <p>Stolpeindstuk voor deuren Embout maclair pour portes Double-casement component for doors</p>	<p>-ST 5 -ST 20</p> 	● ○	P-02-400
	<p>A-02-204</p> <p>Afsluitset enkele deur Pièce d'étanchéité pour porte simple Closer section for single door</p>	<p>-ST 1</p> 	●	P-02-203 P-02-205r2 P-02-206 P-02-207





















Hercules P02

toebehoren ■ accessoires ■ accessories

			
 <p>A-02-205</p> <p>Afsluitset voor dubbele deur Pièce d'étanchéité pour porte double Closer section for double door</p>	<p>-ST 1</p> 		<p>P-02-203 P-02-205r2 P-02-206 P-02-207</p>
 <p>A-02-210</p> <p>Afsluitset enkele deur Pièce d'étanchéité pour porte simple Closer section for single door</p>	<p>-ST 1</p> 		<p>P-02-224 P-02-124</p>
 <p>A-02-211</p> <p>Afsluitset dubbele deur Pièce d'étanchéité pour porte double Closer section for double door</p>	<p>-ST 1</p> 		<p>P-02-224 P-02-124</p>
 <p>A-02-212</p> <p>Afsluitset enkele deur Pièce d'étanchéité pour porte simple Closer section for single door</p>	<p>-ST 1</p> 		<p>P-02-224 P-02-535</p>
 <p>A-02-213</p> <p>Afsluitset dubbele deur Pièce d'étanchéité pour porte double Closer section for double door</p>	<p>-ST 1</p> 		<p>P-02-224 P-02-535</p>



			
<p>A-02-214</p>  <p>Afsluitset enkele deur Pièce d'étanchéité pour porte simple Closer section for single door</p>	<p>-ST 1</p> 		<p>P-02-225 P-02-125</p>
<p>A-02-215</p>  <p>Afsluitset dubbele deur Pièce d'étanchéité pour porte double Closer section for double door</p>	<p>-ST 1</p> 		<p>P-02-225 P-02-125</p>
<p>A-02-216</p>  <p>Afsluitset enkele deur Pièce d'étanchéité pour porte simple Closer section for single door</p>	<p>-ST 1</p> 		<p>P-02-225 P-02-426</p>
<p>A-02-217</p>  <p>Afsluitset dubbele deur Pièce d'étanchéité pour porte double Closer section for double door</p>	<p>-ST 1</p> 		<p>P-02-225 P-02-426</p>
<p>A-02-218</p>  <p>Eindstuk voor deurdrempel Pièce laterale pour seuil Sealing for threshold</p>	<p>-ST 1</p> 		<p>P-02-124 P-02-125</p>

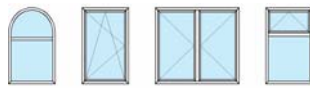

Hercules P02

toebehoren ■ accessoires ■ accessoires

				
 <p>A-02-219</p> <p>Eindstuk voor deurdrempel Pièce laterale pour seuil Sealing for threshold</p>	<p>-ST 1</p> 	●		<p>P-02-535 P-02-901</p>
 <p>A-02-220</p> <p>Eindstuk voor deurdrempel Pièce laterale pour seuil Sealing for threshold</p>	<p>-ST 1</p> 	●		<p>P-02-426 P-02-901</p>
 <p>A-02-224</p> <p>Stolpeindstuk Embout maclair Sealing double casement</p>	<p>-ST 1</p> 	● ○		<p>P-02-424</p>
 <p>A-02-225</p> <p>Stolpeindstuk Embout maclair Sealing double casement</p>	<p>-ST 1</p> 	● ○		<p>P-02-425</p>
 <p>A-02-230</p> <p>Stolpeindstuk voor raam Embout maclair pour fenêtre Sealing double casement prof for window</p>	<p>-ST 1</p> 	● ○		<p>P-02-430</p>





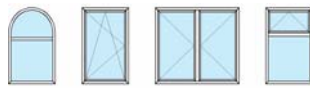







 <p>A-02-240</p> <p>Hulpstuk elektrische slotplaat Accessoire gache électrique Accessory electric lockplate</p>	<p>-ST 1</p> 	 		<p>P-02-125</p>
 <p>A-02-241</p> <p>Hulpstuk elektrische slotplaat Accessoire gache électrique Accessory electric lockplate</p>	<p>-ST 1</p> 	 		<p>P-02-425 P-02-426</p>
 <p>A-02-242</p> <p>Hulpstuk passeren dagschieter Accessoire laisser passer pêne lan- çant Accessory let through latch bolt</p>	<p>-ST 1</p> 			<p>P-02-125 P-02-224</p>
 <p>A-02-306</p> <p>Eindstuk versterkte T-profiel Embout pour traverse renforcée Component for reinforced transom</p>	<p>-ST 6 -ST 24</p> 	 		<p>P-02-306</p>
 <p>A-02-900</p> <p>Eindstuk zwart voor deurdrempel Pièce laterale noir pour bas de porte Sealing black bottom door profile</p>	<p>-ST 1</p> 			<p>P-02-900</p>



Hercules P02

toebehoren ■ accessoires ■ accessories

				
 <p>A-01-305</p> <p>Eindstuk versterkte T-profiel Embout pour traverse renforcé Component for reinforced transom</p>	<p>-ST 6 -ST 24</p> 	 		<p>P-02-305</p>
 <p>A-03-300</p> <p>Afdichting voor T-profiel Pièce d'étanchéité pour traverse Sealing for transom-mullion</p> <p>29 mm</p>	<p>-ST 1</p> 			<p>P-02-A1.. P-02-A3..</p>
 <p>A-03-301</p> <p>Afdichting voor T-profiel Pièce d'étanchéité pour traverse Sealing for transom-mullion</p> <p>45 mm</p>	<p>-ST 1</p> 			<p>P-02-A1.. P-02-A3..</p>
 <p>A-03-302</p> <p>Afdichting voor T-profiel Pièce d'étanchéité pour traverse Sealing for transom-mullion</p> <p>55 mm</p>	<p>-ST 1</p> 			<p>P-02-A1.. P-02-A3..</p>
 <p>A-00-100</p> <p>Waterkapje Busette Drain hole cover</p>	<p>-ST 100</p> <p>-ST 2000</p> 	  RAL 7016M RAL 9001 RAL 9006M RAL 9007M 	 	<p>P-02-1.. P-02-3.. A-KM-5402</p>

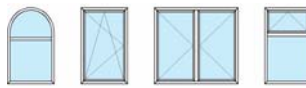

				
	<p>A-00-102</p> <p>Monodrain Blinde ontwatering Monodrain drainage invisible Monodrain Blind drainage</p>	-ST 1 	●	P-02-3..
	<p>A-00-105</p> <p>Verstekhoekje Équerre d'alignement Framing square</p>	-ST 200 -ST 3000 	●	P-02-1.. P-02-2..
	<p>A-00-106</p> <p>Koppelstukje T-profiel Pièce de montage pour traverse Component for transom assembly</p>	-ST 100 -ST 2000 	●	P-02-3..
	<p>A-00-107</p> <p>Koppelstuk glaslat Linea Raccord parclose Linea Connector Glazing bead Linea</p>	-ST 1 		P-6f-...
	<p>A-00-110</p> <p>Schroefblokje Clavette Cleat tensioning block</p>	-ST 40 		A-SH-...













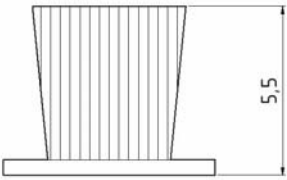

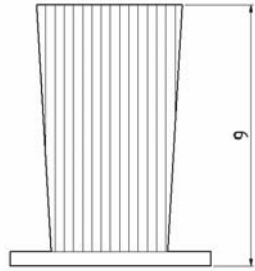
Hercules P02

toebehoren ■ accessoires ■ accessories

				
	<p>A-00-1 1 1</p> <p>Schroef t-verbinders Vis assemblage-t Screw transom bracket</p>	-ST 40 		A-TV-... A-VT-... A-VH-...
	<p>A-00-1 1 2</p> <p>Schroef T-profiel Vis traverse Screw transom-mullion</p>	-ST 100 		P-02-310 P-02-311 P-02-312 P-02-313
	<p>A-00-1 1 5</p> <p>Muuranker Fixation murale Wall anchor</p>	-ST 100 -ST 1000 		P-02-1..
	<p>A-00-1 1 6</p> <p>Plaathouder Porteur de plaque Plate-holder</p>	-ST 1 	●	P-02-1..
	<p>A-00-1 1 7</p> <p>Plaathouder Porteur de plaque Plate-holder</p>	-ST 1 	●	P-02-1..

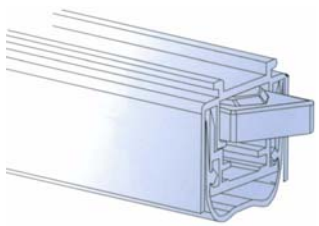



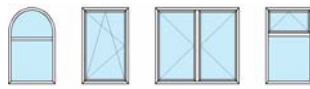







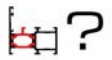
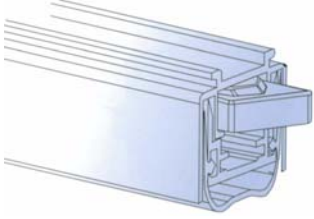

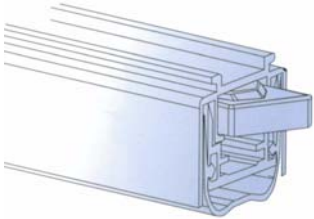
				
 <p>A-00-119</p> <p>Borstel Joint brosse Brush</p>	-LM 325		●	P-00-705 P-00-706
 <p>A-00-121</p> <p>Borstel Joint brosse Brush</p>	-LM 175		●	P-00-203 P-00-204 P-00-205
 <p>A-00-130</p> <p>Hoek middendichting Pièce d'angle moulé joint central Hook central gasket</p>	-ST 20 -ST 200		●	P-02-1.. P-02-3..
 <p>A-00-203</p> <p>Borsteldichting 15mm Joint brosse 15mm Linear brush seal 15mm</p> <p>L = 3000mm</p>	-ST 1		●	P-00-203
 <p>A-00-204</p> <p>Automatische tochtvaldorpel Joint bas de porte automatique Automatic door sealing system</p> <p>L = 700mm</p>	-ST 1			P-02-203 P-02-205r2

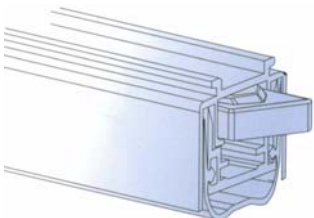

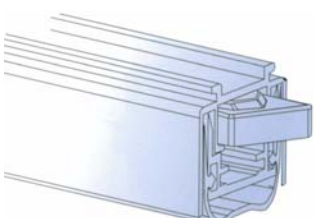

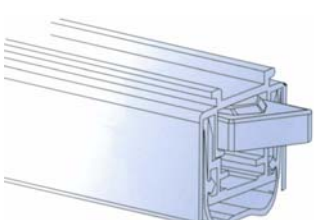







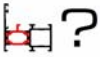
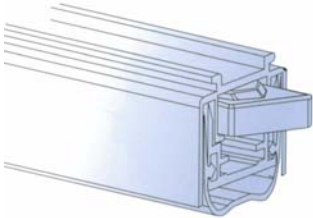

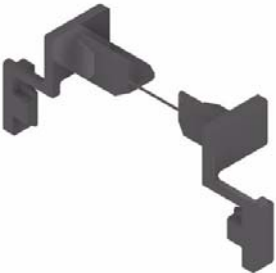

Hercules P02

toebehoren ■ accessoires ■ accessoires

				
 <p>A-00-205</p> <p>Automatische tochtvaldorpel Joint bas de porte automatique Automatic door sealing system</p> <p>L = 800mm</p>	<p>-ST 1</p> 			<p>P-02-203 P-02-205r2</p>
 <p>A-00-206</p> <p>Automatische tochtvaldorpel Joint bas de porte automatique Automatic door sealing system</p> <p>L = 900mm</p>	<p>-ST 1</p> 			<p>P-02-203 P-02-205r2</p>
 <p>A-00-207</p> <p>Automatische tochtvaldorpel Joint bas de porte automatique Automatic door sealing system</p> <p>L = 1000mm</p>	<p>-ST 1</p> 			<p>P-02-203 P-02-205r2</p>
 <p>A-00-208</p> <p>Automatische tochtvaldorpel Joint bas de porte automatique Automatic door sealing system</p> <p>L = 1100mm</p>	<p>-ST 1</p> 			<p>P-02-203 P-02-205r2</p>
 <p>A-00-209</p> <p>Automatische tochtvaldorpel Joint bas de porte automatique Automatic door sealing system</p> <p>L = 1200mm</p>	<p>-ST 1</p> 			<p>P-02-203 P-02-205r2</p>

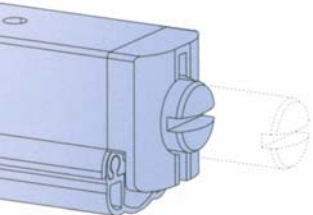



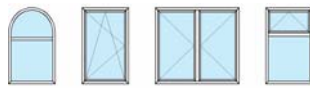







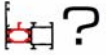
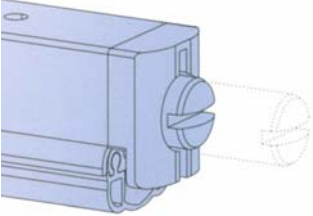

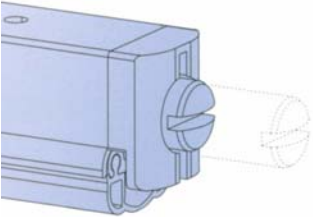
			
 <p>A-00-215</p> <p>Automatische tochtvaldorpel Joint bas de porte automatique Automatic door sealing system</p> <p>L = 1300mm</p>	<p>-ST 1</p> 		<p>P-02-203 P-02-205r2</p>
 <p>A-00-210</p> <p>Eindstuk voor P-00-205 Pièce latérale pour P-00-205 End cap for P-00-205</p>	<p>-ST 1</p> 		<p>P-00-205</p>
 <p>A-00-211</p> <p>Eindstuk voor P-00-206 Pièce latérale pour P-00-206 End cap for P-00-206</p>	<p>-ST 1</p> 		<p>P-00-206</p>
 <p>A-00-212</p> <p>Eindstuk voor P-02-224/225 Embout pour P-02-224/225 End piece for P-02-224/225</p>	<p>-ST 1</p> 		<p>P-02-224 P-02-225</p>
 <p>A-00-304</p> <p>Automatische tochtvaldorpel Joint bas de porte automatique Automatic door sealing system</p> <p>L = 700mm</p>	<p>-ST 1</p> 		<p>P-02-224 P-02-225</p>

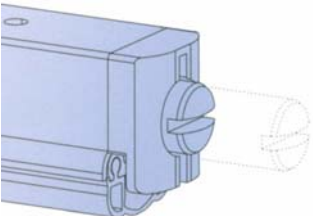

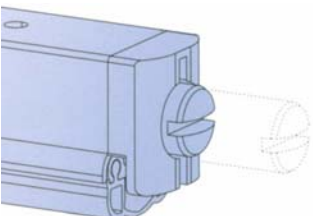
Hercules P02

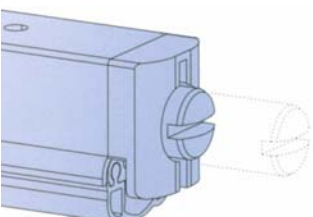
toebehoren ■ accessoires ■ accessoires

				
 <p>A-00-305</p> <p>Automatische tochtvaldorpel Joint bas de porte automatique Automatic door sealing system</p> <p>L = 800mm</p>	<p>-ST 1</p> 		<p>P-02-224 P-02-225</p>	
 <p>A-00-306</p> <p>Automatische tochtvaldorpel Joint bas de porte automatique Automatic door sealing system</p> <p>L = 900mm</p>	<p>-ST 1</p> 		<p>P-02-224 P-02-225</p>	
 <p>A-00-307</p> <p>Automatische tochtvaldorpel Joint bas de porte automatique Automatic door sealing system</p> <p>L = 1000mm</p>	<p>-ST 1</p> 		<p>P-02-224 P-02-225</p>	
 <p>A-00-308</p> <p>Automatische tochtvaldorpel Joint bas de porte automatique Automatic door sealing system</p> <p>L = 1100mm</p>	<p>-ST 1</p> 		<p>P-02-224 P-02-225</p>	
 <p>A-00-309</p> <p>Automatische tochtvaldorpel Joint bas de porte automatique Automatic door sealing system</p> <p>L = 1200mm</p>	<p>-ST 1</p> 		<p>P-02-224 P-02-225</p>	

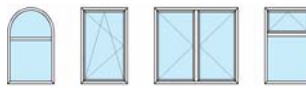

				
 <p>A-00-310</p> <p>Automatische tochtvaldorpel Joint bas de porte automatique Automatic door sealing system</p> <p>L = 1300mm</p>	<p>-ST 1</p> 			<p>P-02-224 P-02-225</p>
 <p>A-00-515</p> <p>Eindstuk voor P-00-515 Embout pour P-00-515 End piece for P-00-515</p>	<p>-ST 1</p> 			<p>P-00-515</p>
 <p>A-00-700</p> <p>Blindlinknagel Rivet Rivet</p>	<p>-ST 100</p> 			<p>P-00-702</p>
 <p>A-00-702</p> <p>Eindstuk waterneus Embout pour rejet d'eau Component for cover profile</p>	<p>-ST 10 -ST 100</p> 			<p>P-00-702</p>
 <p>A-00-703</p> <p>Klemstukje voor P-00-703 Clips pour P-00-703 Clips for P-00-703</p>	<p>-ST 10 -ST 100</p> 			<p>P-02-1..</p>



Hercules P02

toebehoren ■ accessoires ■ accessories

 <p>A-00-704</p> <p>Klemstuk Clips Clip</p>	-ST 100			P-02-1..
 <p>A-00-705</p> <p>Inloopstuk rolluikgeleider Guidage pour coulisse à volet Enterpiece rolling shutter</p>	-ST 10			P-00-703 P-00-704 P-00-706
 <p>A-00-706</p> <p>Aandrukrol voor rolluik Rouleau de renvoi pour volet Push roll for roller</p>	-ST 10 -ST 100			P-00-705 P-00-707
 <p>A-00-720</p> <p>Sluitstuk voor P-02-720 Bouchon pour P-02-720 Cap for P-02-720</p>	-ST 10			P-02-720
 <p>A-00-725</p> <p>Eindrubber blinde afwateringsprofiel Joint finale pour profilé évac.invisible eaux Endgasket for invisible water outlet profile</p>	-ST 100			P-02-723 P-02-724 P-02-725 P-02-726



			
 <p>A-00-850</p> <p>Boormal voor variabele hoek Gabarit de percage clame variable Drilling jigg for adjustable bracket</p>	<p>-ST 1</p> 		<p>P-02-1...</p>
 <p>A-00-851</p> <p>Boormal voor variabele hoek Gabarit de percage clame variable Drilling jigg for adjustable bracket</p>	<p>-ST 1</p> 		<p>P-02-1...</p>
 <p>A-00-852</p> <p>Boormal voor variabele hoek Gabarit de percage clame variable Drilling jigg for adjustable bracket</p>	<p>-ST 1</p> 		<p>P-02-2...</p>
 <p>A-00-853</p> <p>Boormal voor variabele hoek Gabarit de percage clame variable Drilling jigg for adjustable bracket</p>	<p>-ST 1</p> 		<p>P-02-2...</p>
 <p>A-00-854</p> <p>Boormal voor variabele hoek Gabarit de percage clame variable Drilling jigg for adjustable bracket</p>	<p>-ST 1</p> 		<p>P-02-3...</p>

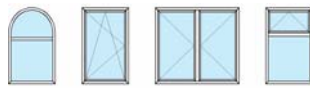

Hercules P02

toebehoren ■ accessoires ■ accessories

				
 <p>A-00-855</p> <p>Boormal voor variabele hoek Gabarit de percage clame variable Drilling jigg for adjustable bracket</p>	-ST 1			P-02-3...
 <p>A-00-856</p> <p>Boormal voor t-profiel met schroefgaten Gabarit de percage clame variable pour traverse avec trou de vis Drilling jigg for transom-mullion with screwholes</p>	-ST 1			P-02-31..
 <p>A-00-857</p> <p>Boormal voor t-profiel met schroefgaten Gabarit de percage clame variable pour traverse avec trou de vis Drilling jigg for transom-mullion with screwholes</p>	-ST 1			P-02-31..
 <p>A-00-858</p> <p>Boormal voor t-profiel Gabarit de percage pour traverse Drilling jigg for transom-mullion</p>	-ST 1			P-02-1.. P-02-3..
 <p>A-00-859</p> <p>Boormal voor t-profiel Gabarit de percage pour traverse Drilling jigg for transom-mullion</p>	-ST 1			P-02-1.. P-02-3..



				
	<p>A-00-900</p> <p>Secondenlijm Voor Rubber En Plastiek Colle Ultra Rapides Pour EPDM et Plastique Glue For Gaskets And Plastics</p> <p>20 gr</p>	-ST 1 		
	<p>A-00-901</p> <p>Lijm voor verstekhoek Colle pour équerre Glue for cornercleat</p> <p>310 ml</p>	-ST 1 		
	<p>A-00-902</p> <p>Afdichtingskit voor versteknaden transparant Silicone transparent One component adhesive/sealant transparent</p> <p>290 ml</p>	-ST 1 		
	<p>A-00-903</p> <p>Glue cleaner Glue cleaner Glue cleaner</p> <p>500 ml</p>	-ST 1 		
	<p>A-00-904</p> <p>Periodi-clean Periodi-clean Periodi-clean</p> <p>500 ml</p>	-ST 1 		



Hercules P02

toebehoren ■ accessoires ■ accessoires

				
	<p>A-00-905</p> <p>Heavy cleaner Heavy cleaner Heavy cleaner</p> <p>500 gr</p>	-ST 1 		
	<p>A-00-906</p> <p>Anodigum Anodigum Anodigum</p>	-ST 1 		
	<p>A-00-907</p> <p>Gloss en protector Gloss en protector Gloss en protector</p> <p>500 ml</p>	-ST 1 		
	<p>A-00-908</p> <p>Unionzement Unionzement Unionzement</p> <p>225 gr</p>	-ST 1 		
	<p>A-00-909</p> <p>Unionzement Unionzement Unionzement</p> <p>310 ml</p>	-ST 1 		





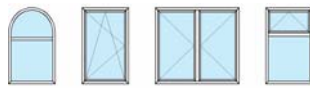







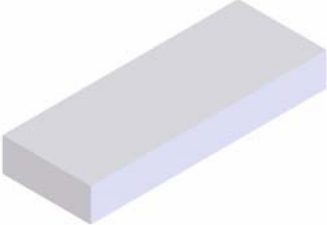







				
	<p>A-00-910</p> <p>Retoucheerstift Marqueur de retouche Touch up marker</p> <p>12 ml</p>	-ST 1 		
	<p>A-00-911</p> <p>Retoucheerstift transparent Marqueur de retouche transparente Touch up marker transparent</p> <p>12 ml</p>	-ST 1 		
	<p>A-00-915</p> <p>Multifunctions Spray Multifunctions Spray Multifunctions Spray</p> <p>500 ml</p>	-ST 1 		
	<p>A-00-920</p> <p>Dubbelzijdige kleefband Ruban adhésif double face Double coated adhesive tape</p> <p>33 m</p>	-ST 1 		P-00-610
	<p>A-00-950</p> <p>Klemblok 22mm Bloc de serrage 22mm Clamp block 22mm</p> <p>22x120x45mm</p>	-ST 1 		

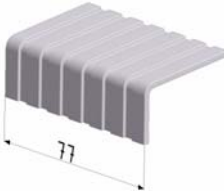

Hercules P02

toebehoren ■ accessoires ■ accessories

				
 <p>A-00-951</p> <p>Klemblok 17mm Bloc de serrage 17mm Clamp block 17mm</p> <p>17x120x45mm</p>	<p>-ST 1</p> 			
 <p>A-00-E140</p> <p>Dorpelafsluitstukjes 140mm Pièces paténales seuil 140mm Sealing for windowsill 140mm</p>	<p>-ST 1</p> 	 		P-00-72.
 <p>A-00-E230</p> <p>Dorpelafsluitstukjes 230mm Pièces paténales seuil 230mm Sealing for windowsill 230mm</p>	<p>-ST 1</p> 	 		P-00-72.
 <p>A-00-K050</p> <p>Koppelstuk raamdorpel P-00-720 Pièce raccord seuil P-00-720 Connector for windowsill P-00-720</p>	<p>-ST 1</p> 			P-00-720
 <p>A-00-K080</p> <p>Koppelstuk raamdorpel P-00-721 Pièce raccord seuil P-00-721 Connector for windowsill P-00-721</p>	<p>-ST 1</p> 			P-00-721



				
	<p>A-00-K110</p> <p>Koppelstuk raamdorpel P-00-722 Pièce raccord seuil P-00-722 Connector for windowsill P-00-722</p>	-ST 1 		P-00-722
	<p>A-00-K140</p> <p>Koppelstuk raamdorpel P-00-723 Pièce raccord seuil P-00-723 Connector for windowsill P-00-723</p>	-ST 1 		P-00-723
	<p>A-00-K170</p> <p>Koppelstuk raamdorpel P-00-724 Pièce raccord seuil P-00-724 Connector for windowsill P-00-724</p>	-ST 1 		P-00-724
	<p>A-00-K200</p> <p>Koppelstuk raamdorpel P-00-725 Pièce raccord seuil P-00-725 Connector for windowsill P-00-725</p>	-ST 1 		P-00-725
	<p>A-00-K230</p> <p>Koppelstuk raamdorpel P-00-726 Pièce raccord seuil P-00-726 Connector for windowsill P-00-726</p>	-ST 1 		P-00-726

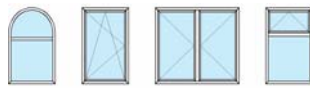











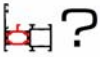



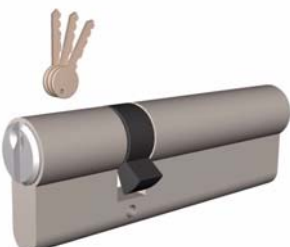

Hercules P02

toebehoren ■ accessoires ■ accessories

			
 <p>A-00-CE30</p> <p>Halve Cilinder 30 Demi-cylindre 30 Half cylinder 30</p> <p>A-00-GE30 </p>	<p>-ST 1</p> 		
 <p>A-00-CE35</p> <p>Halve Cilinder 35 Demi-cylindre 35 Half cylinder 35</p> <p>A-00-GE35 </p>	<p>-ST 1</p> 		
 <p>A-00-CE55</p> <p>Halve Cilinder 55 Demi-cylindre 55 Half cylinder 55</p> <p>A-00-GE55 </p>	<p>-ST 1</p> 		
 <p>A-00-CE65</p> <p>Halve Cilinder 65 Demi-cylindre 65 Half cylinder 65</p> <p>A-00-GE65 </p>	<p>-ST 1</p> 		
 <p>A-00-CE70</p> <p>Halve Cilinder 70 Demi-cylindre 70 Half cylinder 70</p> <p>A-00-GE70 </p>	<p>-ST 1</p> 		





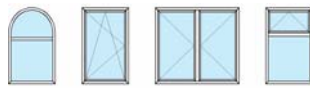











			
 <p>A-00-CE3045</p> <p>Cilinder 30/45 Cylindre 30/45 Cilinder 30/45</p> <p>A-00-GE3045 </p>	<p>-ST 1</p> 		
 <p>A-00-CE3055</p> <p>Cilinder 30/55 Cylindre 30/55 Cilinder 30/55</p> <p>A-00-GE3055 </p>	<p>-ST 1</p> 		
 <p>A-00-CE3065</p> <p>Cilinder 30/65 Cylindre 30/65 Cilinder 30/65</p> <p>A-00-GE3065 </p>	<p>-ST 1</p> 		
 <p>A-00-CE3070</p> <p>Cilinder 30/70 Cylindre 30/70 Cilinder 30/70</p> <p>A-00-GE3070 </p>	<p>-ST 1</p> 		
 <p>A-00-CE3555</p> <p>Cilinder 35/55 Cylindre 35/55 Cilinder 35/55</p> <p>A-00-GE3555 </p>	<p>-ST 1</p> 		



Hercules P02

toebehoren ■ accessoires ■ accessoires

			
 <p>A-00-CE3560</p> <p>Cilinder 35/60 Cylindre 35/60 Cilinder 35/60</p> <p>A-00-GE3560 </p>	<p>-ST 1</p> 		
 <p>A-00-CV3045</p> <p>Veiligheidscilinder 30/45 Cylindre de sécurité 30/45 Security cilinder 30/45</p>	<p>-ST 1</p> 		
 <p>A-00-CV3055</p> <p>Veiligheidscilinder 30/55 Cylindre de sécurité 30/55 Security cilinder 30/55</p>	<p>-ST 1</p> 		
 <p>A-00-CV3065</p> <p>Veiligheidscilinder 30/65 Cylindre de sécurité 30/65 Security cilinder 30/65</p>	<p>-ST 1</p> 		
 <p>A-00-CV3070</p> <p>Veiligheidscilinder 30/70 Cylindre de sécurité 30/70 Security cilinder 30/70</p>	<p>-ST 1</p> 		



			
 <p>A-00-CV3555</p> <p>Veiligheidscilinder 35/55 Cylindre de sécurité 35/55 Security cilinder 35/55</p>	<p>-ST 1</p> 		
 <p>A-00-CV3560</p> <p>Veiligheidscilinder 35/60 Cylindre de sécurité 35/60 Security cilinder 35/60</p>	<p>-ST 1</p> 		
 <p>A-GS-100</p> <p>Beglazingsrubber Joint de vitrage Sealing gasket</p>	<p>-LM 100</p> 		<p>P-02-1.. P-02-2.. P-02-3..</p>
 <p>A-GS-110</p> <p>Beglazingsrubber Joint de vitrage Sealing gasket</p>	<p>-LM 100</p> 		<p>P-02-1.. P-02-2.. P-02-3..</p>
 <p>A-GS-115</p> <p>Aanslagdichting Joint de frappe Flipper gasket</p> 	<p>-LM 100</p> 		<p>P-02-1.. P-02-2.. P-02-3..</p>



Hercules P02

toebehoren ■ accessoires ■ accessories

				
	A-GS-130 Middendichting Joint central Central gasket	-LM 50 	●	P-02-1.. P-02-3..
	A-GS-131 Aanslagdichting ramen Joint de frappe fenêtres Flipper gasket windows	-LM 100 	●	P-02-2..
	A-GS-133 Aanslagdichting deuren Joint de frappe portes Flipper gasket doors	-LM 100 	●	P-02-2..
	A-GS-303 Beglazingsrubber 3mm Joint de vitrage 3mm Sealing gasket 3mm	-LM 100 	●	P-02-1.. P-02-2.. P-02-3..
	A-GS-304 Beglazingsrubber 4mm Joint de vitrage 4mm Sealing gasket 4mm	-LM 100 	●	P-02-1.. P-02-2.. P-02-3..



				
	<p>A-GS-305</p> <p>Beglazingsrubber 5mm Joint de vitrage 5mm Sealing gasket 5mm</p>	<p>-LM 100</p> 	●	<p>P-02-1.. P-02-2.. P-02-3..</p>
	<p>A-GS-306</p> <p>Beglazingsrubber 6mm Joint de vitrage 6mm Sealing gasket 6mm</p>	<p>-LM 100</p> 	●	<p>P-02-1.. P-02-2.. P-02-3..</p>
	<p>A-GS-308</p> <p>Beglazingsrubber 8mm Joint de vitrage 8mm Sealing gasket 8mm</p>	<p>-LM 100</p> 	●	<p>P-02-1.. P-02-2.. P-02-3..</p>
	<p>A-GS-700</p> <p>Koppelrubber Joint de couplage Coupling gasket</p>	<p>-LM 100</p> 	●	<p>P-02-1..</p>
	<p>A-GS-701</p> <p>Koppelrubber Joint de couplage Coupling gasket</p>	<p>-LM 100</p> 	●	<p>P-02-530</p>

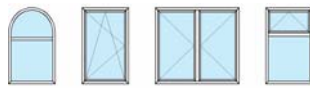

Hercules P02

toebehoren ■ accessoires ■ accessoires

				
	A-GS-703 Plaatrubber Joint plaque Gasket plate	-LM 50 	●	P-00-106
	A-GS-706 Basisrubber Joint de base Base gasket	-LM 25 	●	P-02-1..
	A-PH-1110 Pershoek Équerre à serrer Clamping corner	-ST 20 -ST 100 -ST 500 		P-02-200 P-02-210 P-02-220
	A-PH-1115 Pershoek Équerre à serrer Clamping corner	-ST 20 -ST 100 		P-02-116 P-02-300
	A-PH-1415 Pershoek Équerre à serrer Clamping corner	-ST 20 -ST 100 -ST 300 		P-02-100 P-02-107 P-02-111



				
	<p>A-PH-1430</p> <p>Pershoek Équerre à sertir Clamping corner</p>	<p>-ST 20 -ST 100</p> 		<p>P-02-230 P-02-240</p>
	<p>A-PH-1441</p> <p>Pershoek Équerre à sertir Clamping corner</p>	<p>-ST 20 -ST 100</p> 		<p>P-02-108</p>
	<p>A-PH-1464</p> <p>Pershoek Équerre à sertir Clamping corner</p>	<p>-ST 20 -ST 100</p> 		<p>P-02-115</p>
	<p>A-PH-1607</p> <p>Pershoek Équerre à sertir Clamping corner</p>	<p>-ST 20 -ST 100</p> 		<p>P-02-405</p>
	<p>A-PH-1610</p> <p>Pershoek Équerre à sertir Clamping corner</p>	<p>-ST 20 -ST 100</p> 		<p>P-02-230 P-02-240</p>

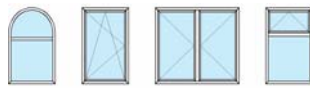

Hercules P02

toebehoren ■ accessoires ■ accessoires

				
	A-PH-1621 Pershoek Équerre à sertir Clamping corner	-ST 20 -ST 200 		P-02-100 P-02-107 P-02-108 P-02-111 P-02-115 P-02-116 P-02-300 P-02-309
	A-PH-1630 Pershoek Équerre à sertir Clamping corner	-ST 20 -ST 200 		P-02-200 P-02-210 P-02-220
	A-PH-1665 Pershoek Équerre à sertir Clamping corner	-ST 20 -ST 100 		P-02-109 P-02-110
	A-PH-2314 Pershoek Équerre à sertir Clamping corner	-ST 20 -ST 100 		P-02-104
	A-PH-2520 Pershoek Équerre à sertir Clamping corner	-ST 20 -ST 100 		P-02-104



				
	<p>A-PH-2710</p> <p>Pershoek Équerre à sertir Clamping corner</p>	<p>-ST 20 -ST 100</p> 		<p>P-02-201 P-02-211</p>
	<p>A-PH-2715</p> <p>Pershoek Équerre à sertir Clamping corner</p>	<p>-ST 20 -ST 100</p> 		<p>P-02-301</p>
	<p>A-PH-2730</p> <p>Pershoek Équerre à sertir Clamping corner</p>	<p>-ST 20 -ST 100</p> 		<p>P-02-231 P-02-241</p>
	<p>A-PH-3010</p> <p>Pershoek Équerre à sertir Clamping corner</p>	<p>-ST 20 -ST 100</p> 		<p>P-02-231 P-02-241</p>
	<p>A-PH-3015</p> <p>Pershoek Équerre à sertir Clamping corner</p>	<p>-ST 20 -ST 100</p> 		<p>P-02-101 P-02-113</p>

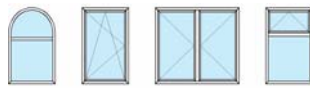

Hercules P02

toebehoren ■ accessoires ■ accessoires

				
	A-PH-3025 Pershoek Équerre à sertir Clamping corner	-ST 4 		P-02-405
	A-PH-3221 Pershoek Équerre à sertir Clamping corner	-ST 20 -ST 100 		P-02-101 P-02-109 P-02-110 P-02-113 P-02-301
	A-PH-3230 Pershoek Équerre à sertir Clamping corner	-ST 20 -ST 100 		P-02-201 P-02-211
	A-PH-3706 Pershoek Équerre à sertir Clamping corner	-ST 20 -ST 100 		P-02-203 P-02-213
	A-PH-3709 Pershoek Équerre à sertir Clamping corner	-ST 20 -ST 100 		P-02-309



			
 <p>A-PH-3710</p> <p>Pershoek Équerre à sertir Clamping corner</p>	-ST 20 -ST 100 		P-02-202 P-02-212
 <p>A-PH-3715</p> <p>Pershoek Équerre à sertir Clamping corner</p>	-ST 20 -ST 100 		P-02-302
 <p>A-PH-4006</p> <p>Pershoek Équerre à sertir Clamping corner</p>	-ST 20 -ST 200 		P-02-124 P-02-125 P-02-224 P-02-225
 <p>A-PH-4015</p> <p>Pershoek Équerre à sertir Clamping corner</p>	-ST 20 -ST 100 		P-02-102
 <p>A-PH-4206</p> <p>Pershoek Équerre à sertir Clamping corner</p>	-ST 20 -ST 100 		P-02-205r2

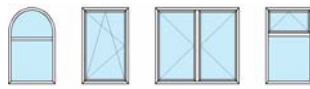

Hercules P02

toebehoren ■ accessoires ■ accessoires

				
 <p>A-PH-4207</p> <p>Pershoek Équerre à sertir Clamping corner</p>	<p>-ST 20 -ST 100</p> 			P-02-214
 <p>A-PH-4221</p> <p>Pershoek Équerre à sertir Clamping corner</p>	<p>-ST 20 -ST 100</p> 			P-02-102 P-02-302
 <p>A-PH-4229</p> <p>Pershoek Équerre à sertir Clamping corner</p>	<p>-ST 20 -ST 100</p> 			P-02-205r2
 <p>A-PH-4230</p> <p>Pershoek Équerre à sertir Clamping corner</p>	<p>-ST 20 -ST 100</p> 			P-02-202 P-02-203 P-02-212 P-02-213
 <p>A-PH-4707</p> <p>Pershoek Équerre à sertir Clamping corner</p>	<p>-ST 20 -ST 100</p> 			P-02-206 P-02-207



			
 <p>A-PH-4709</p> <p>Pershoek Équerre à sertir Clamping corner</p>	<p>-ST 20 -ST 100</p> 		<p>P-02-319</p>
 <p>A-PH-4725</p> <p>Pershoek Équerre à sertir Clamping corner</p>	<p>-ST 20</p> 		<p>P-02-124 P-02-125 P-02-224 P-02-225</p>
 <p>A-PH-4730</p> <p>Pershoek Équerre à sertir Clamping corner</p>	<p>-ST 20 -ST 100</p> 		<p>P-02-206 P-02-207 P-02-214</p>
 <p>A-SH-1110</p> <p>Schroefhoek Équerre à visser Square coupling joint</p>	<p>-ST 4 -ST 40</p> 		<p>P-02-200 P-02-210 P-02-220</p>  <p>A-KM-5401</p>
 <p>A-SH-1415</p> <p>Schroefhoek Équerre à visser Square coupling joint</p>	<p>-ST 4 -ST 40</p> 		<p>P-02-100 P-02-111</p>  <p>A-KM-5401</p>

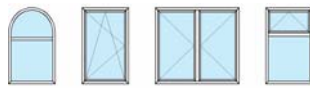

Hercules P02

toebehoren ■ accessoires ■ accessories

				
	A-SH-1441 Schroefhoek Équerre à visser Square coupling joint	-ST 4 -ST 40 		P-02-108  A-KM-5401
	A-SH-1464 Schroefhoek Équerre à visser Square coupling joint	-ST 4 -ST 40 		P-02-115  A-KM-5401
	A-SH-1621 Schroefhoek Équerre à visser Square coupling joint	-ST 4 -ST 40 		P-02-100 P-02-107 P-02-108 P-02-111 P-02-116 P-02-300 P-02-309  A-KM-5401 P-02-115  A-KM-5403
	A-SH-1630 Schroefhoek Équerre à visser Square coupling joint	-ST 4 -ST 40 		P-02-200 P-02-210 P-02-220  A-KM-5401
	A-SH-1663 Schroefhoek Équerre à visser Square coupling joint	-ST 4 -ST 40 		P-02-110  A-KM-5403

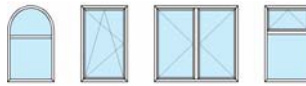

				
	<p>A-SH-1665</p> <p>Schroefhoek Équerre à visser Square coupling joint</p>	<p>-ST 4 -ST 40</p> 		<p>P-02-109</p>  A-KM-5403
	<p>A-SH-2314</p> <p>Schroefhoek Équerre à visser Square coupling joint</p>	<p>-ST 4 -ST 40</p> 		<p>P-02-104</p>  A-KM-5401
	<p>A-SH-2520</p> <p>Schroefhoek Équerre à visser Square coupling joint</p>	<p>-ST 4 -ST 40</p> 		<p>P-02-104</p>  A-KM-5401
	<p>A-SH-2710</p> <p>Schroefhoek Équerre à visser Square coupling joint</p>	<p>-ST 4 -ST 40</p> 		<p>P-02-201 P-02-211</p>  A-KM-5401
	<p>A-SH-3015</p> <p>Schroefhoek Équerre à visser Square coupling joint</p>	<p>-ST 4 -ST 40</p> 		<p>P-02-101 P-02-113</p>  A-KM-5401

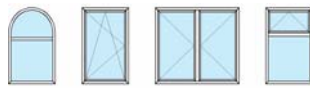

Hercules P02

toebehoren ■ accessoires ■ accessoires

				
 <p>A-SH-3025</p> <p>Schroefhoek Équerre à visser Square coupling joint</p>	<p>-ST 4</p> 		 <p>P-02-405</p>  <p>A-KM-5401</p>	
 <p>A-SH-3221</p> <p>Schroefhoek Équerre à visser Square coupling joint</p>	<p>-ST 4 -ST 40</p> 		<p>P-02-101 P-02-113 P-02-301</p>  <p>A-KM-5401</p> <p>P-02-109 P-02-110</p>  <p>A-KM-5403</p>	
 <p>A-SH-3230</p> <p>Schroefhoek Équerre à visser Square coupling joint</p>	<p>-ST 4 -ST 40</p> 		<p>P-02-201 P-02-211</p>  <p>A-KM-5401</p>	
 <p>A-SH-3709</p> <p>Schroefhoek Équerre à visser Square coupling joint</p>	<p>-ST 4 -ST 40</p> 		<p>P-02-309</p>  <p>A-KM-5401</p>	
 <p>A-SH-3710</p> <p>Schroefhoek Équerre à visser Square coupling joint</p>	<p>-ST 4 -ST 40</p> 		<p>P-02-202 P-02-212</p>  <p>A-KM-5401</p>	



			
 <p>A-SH-4015</p> <p>Schroefhoek Équerre à visser Square coupling joint</p>	<p>-ST 4 -ST 40</p> 		<p>P-02-102</p>  <p>A-KM-5401</p>
 <p>A-SH-4221</p> <p>Schroefhoek Équerre à visser Square coupling joint</p>	<p>-ST 4 -ST 40</p> 		<p>P-02-102 P-02-302</p>  <p>A-KM-5401</p>
 <p>A-SH-4229</p> <p>Schroefhoek Équerre à visser Square coupling joint</p>	<p>-ST 4 -ST 40</p> 		<p>P-02-205r2</p>  <p>A-KM-5403</p>
 <p>A-SH-4230</p> <p>Schroefhoek Équerre à visser Square coupling joint</p>	<p>-ST 4 -ST 40</p> 		<p>P-02-202 P-02-212</p>  <p>A-KM-5401</p> <p>P-02-203 P-02-213</p>  <p>A-KM-5403</p>
 <p>A-SH-4709</p> <p>Schroefhoek Équerre à visser Square coupling joint</p>	<p>-ST 4 -ST 40</p> 		<p>P-02-319</p>  <p>A-KM-5403</p>

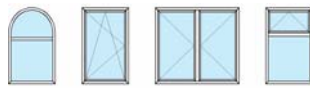

Hercules P02

toebehoren ■ accessoires ■ accessoires

			
 <p>A-SH-4730</p> <p>Schroefhoek Équerre à visser Square coupling joint</p>	<p>-ST 4 -ST 40</p> 		<p>P-02-206 P-02-207 P-02-214</p>  <p>A-KM-5403</p>
 <p>A-TV-001</p> <p>T-verbinding Attache traverse Connecting component for transom</p>	<p>-ST 10</p> 		<p>P-02-100 P-02-111 P-02-300 P-02-303 P-02-304 P-02-305 P-02-315 P-02-320</p>  <p>A-KM-5401</p>
 <p>A-TV-002</p> <p>T-verbinding Attache traverse Connecting component for transom</p>	<p>-ST 10</p> 		<p>P-02-101 P-02-113 P-02-301 P-02-306</p>  <p>A-KM-5401</p>
 <p>A-TV-003</p> <p>T-verbinding Attache traverse Connecting component for transom</p>	<p>-ST 10</p> 		<p>P-02-102 P-02-302</p>  <p>A-KM-5401</p>
 <p>A-TV-005</p> <p>T-verbinding Attache traverse Connecting component for transom</p>	<p>-ST 10</p> 		<p>P-02-300 P-02-305 P-02-315 P-02-320</p>  <p>A-KM-5401</p>



				
	<p>A-TV-051</p> <p>T-verbinding Attache traverse Connecting component for transom</p>	-ST 10 		<p>P-02-300 P-02-305 P-02-315 P-02-320</p>  A-KM-5401
	<p>A-TV-052</p> <p>T-verbinding Attache traverse Connecting component for transom</p>	-ST 10 		<p>P-02-301 P-02-303 P-02-304 P-02-306</p>  A-KM-5401
	<p>A-TV-053</p> <p>T-verbinding Attache traverse Connecting component for transom</p>	-ST 10 		<p>P-02-302</p>  A-KM-5401
	<p>A-TV-054</p> <p>T-verbinding Attache traverse Connecting component for transom</p>	-ST 10 		<p>P-02-100 P-02-111</p>  A-KM-5401
	<p>A-TV-055</p> <p>T-verbinding Attache traverse Connecting component for transom</p>	-ST 10 		<p>P-02-101 P-02-113</p>  A-KM-5401

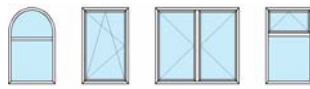

Hercules P02

toebehoren ■ accessoires ■ accessories

			
 <p>A-TV-056</p> <p>T-verbinding Attache traverse Connecting component for transom</p>	<p>-ST 10</p> 		<p>P-02-102</p>  <p>A-KM-5401</p>
 <p>A-TV-057</p> <p>T-verbinding Attache traverse Connecting component for transom</p>	<p>-ST 10</p> 		<p>P-02-300 P-02-305 P-02-315 P-02-320</p>  <p>A-KM-5401</p>
 <p>A-TV-064</p> <p>T-verbinding Attache traverse Connecting component for transom</p>	<p>-ST 10</p> 		<p>P-02-300 P-02-305 P-02-315 P-02-320</p>  <p>A-KM-5401</p>
 <p>A-TV-065</p> <p>T-verbinding Attache traverse Connecting component for transom</p>	<p>-ST 10</p> 		<p>P-02-301 P-02-303 P-02-304 P-02-306</p>  <p>A-KM-5401</p>
 <p>A-TV-066</p> <p>T-verbinding Attache traverse Connecting component for transom</p>	<p>-ST 10</p> 		<p>P-02-302</p>  <p>A-KM-5401</p>



				
 <p>A-TV-067</p> <p>T-verbinding Attache traverse Connecting component for transom</p>	-ST 10			<p>P-02-100 P-02-111</p>  A-KM-5401
 <p>A-TV-068</p> <p>T-verbinding Attache traverse Connecting component for transom</p>	-ST 10			<p>P-02-101 P-02-113</p>  A-KM-5401
 <p>A-TV-069</p> <p>T-verbinding Attache traverse Connecting component for transom</p>	-ST 10			<p>P-02-102</p>  A-KM-5401
 <p>A-VH-1110</p> <p>Variabele hoekverbinding Équerre à angle variable Adjustable connecting component</p>	-ST 10			<p>P-02-200 P-02-210</p>
 <p>A-VH-1415</p> <p>Variabele hoekverbinding Équerre à angle variable Adjustable connecting component</p>	-ST 10			<p>P-02-100 P-02-111</p>

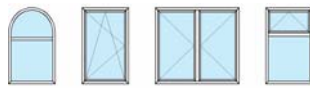

Hercules P02

toebehoren ■ accessoires ■ accessories

				
 <p>A-VH-1621</p> <p>Variabele hoekverbinding Équerre à angle variable Adjustable connecting component</p>	-ST 10			P-02-100 P-02-111 P-02-116 P-02-300
 <p>A-VH-1630</p> <p>Variabele hoekverbinding Équerre à angle variable Adjustable connecting component</p>	-ST 10			P-02-200 P-02-210
 <p>A-VH-1664</p> <p>Variabele hoekverbinding Équerre à angle variable Adjustable connecting component</p>	-ST 10			P-02-109 P-02-110
 <p>A-VH-3015</p> <p>Variabele hoekverbinding Équerre à angle variable Adjustable connecting component</p>	-ST 10			P-02-101 P-02-113
 <p>A-VH-3221</p> <p>Variabele hoekverbinding Équerre à angle variable Adjustable connecting component</p>	-ST 10			P-02-101 P-02-109 P-02-110 P-02-113 P-02-301



				
	A-VH-4015 Variabele hoekverbinding Équerre à angle variable Adjustable connecting component	-ST 10 		P-02-102
	A-VH-4221 Variabele hoekverbinding Équerre à angle variable Adjustable connecting component	-ST 10 		P-02-102 P-02-302
	A-VT-1115 Variabele T-verbinding Attacher traverse à angle variable Adjustable connecting component for transom	-ST 10 		P-02-300 P-02-320
	A-VT-1621 Variabele T-verbinding Attacher traverse à angle variable Adjustable connecting component for transom	-ST 10 		P-02-300 P-02-320
	A-VT-2715L Variabele T-verbinding Attacher traverse à angle variable Adjustable connecting component for transom	-ST 10 		P-02-301

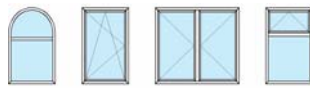

Hercules P02

toebehoren ■ accessoires ■ accessories

				
 <p>A-VT-2715R</p> <p>Variabele T-verbinding Attacher traverse à angle variable Adjustable connecting component for transom</p>	-ST 10 		P-02-301	
 <p>A-VT-3221L</p> <p>Variabele T-verbinding Attacher traverse à angle variable Adjustable connecting component for transom</p>	-ST 10 		P-02-301	
 <p>A-VT-3221R</p> <p>Variabele T-verbinding Attacher traverse à angle variable Adjustable connecting component for transom</p>	-ST 10 		P-02-301	
 <p>A-KM-5401</p> <p>Kapmatrijs Outillage de poinçonnage Punching tool</p>	-ST 1 			
 <p>A-KM-5402</p> <p>Kapmatrijs Outillage de poinçonnage Punching tool</p>	-ST 1 			





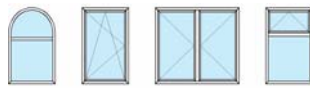











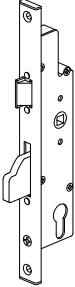

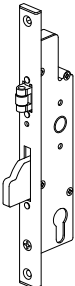
				
 <p>A-KM-5403</p> <p>Kapmatrijs Outilsage de poinçonnage Punching tool</p>	-ST 1 			
 <p>A-KM-54PD</p> <p>beveiligingspedaal voor A-KM-54PO Pédale de sécurité pour A-KM-54PO Safety pedal for A-KM-54PO</p>	-ST 1 			
 <p>A-KM-54PO</p> <p>Pneumatische eenheid Unite pneumatique Pneumatic unit</p>	-ST 1 			
 <p>A-KM-54SO</p> <p>Sokkel voor A-KM-54PO Socle pour A-KM-54PO Support for A-KM-54PO</p>	-ST 1 			
 <p>A-BS-237</p> <p>5 puntslot met haak en pen Serrure 5-points à crochet et pêne 5 point lock with pen</p>	-ST 1 			P-02-206













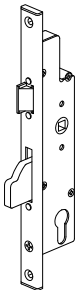

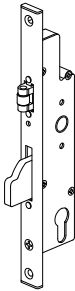



Hercules P02

toebehoren ■ accessoires ■ accessories

				
	<p>A-BS-238</p> <p>5 puntrolslot met haak en rol Serrure 5-points à crochet et rouleau 5 point lock with rol</p>	-ST 1 		P-02-206
	<p>A-BS-240</p> <p>Veiligheidsslot met pen Serrure de sécurité à pêne Security lock with pen</p>	-ST 1 		
	<p>A-BS-241</p> <p>Veiligheidsslot met rol Serrure de sécurité à rouleau Security lock with rol</p>	-ST 1 		
	<p>A-BS-242</p> <p>5 puntslot met haak en pen Serrure 5-points à crochet et pêne 5 point lock with pin</p>	-ST 1 		
	<p>A-BS-243</p> <p>5 puntrolslot met haak en rol Serrure 5-points à crochet et rouleau 5 point lock with rol</p>	-ST 1 		





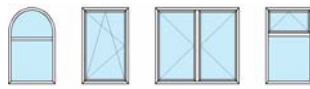







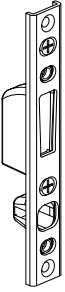

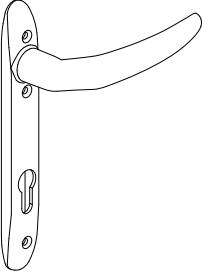
				
	<p>A-BS-245</p> <p>Veiligheidsslot met pen Serrure de sécurité à pêne Security lock with pen</p>	-ST 1 		
	<p>A-BS-246</p> <p>Veiligheidsslot met rol Serrure de sécurité à rouleau Security lock with rol</p>	-ST 1 		
	<p>A-BS-247</p> <p>5 puntslot met haak en pen Serrure 5-points à crochet et pêne 5 point lock with pin</p>	-ST 1 		
	<p>A-BS-248</p> <p>5 puntrolslot met haak en rol Serrure 5-points à crochet et rouleau 5 point lock with rol</p>	-ST 1 		
	<p>A-BS-250</p> <p>Slotplaat midden 5.5mm Gache central 5.5mm Central lockplate 5.5mm</p>	-ST 1 		

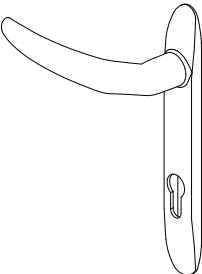

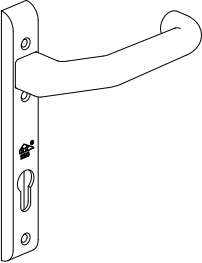

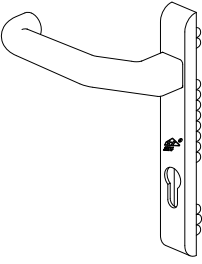



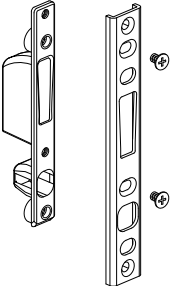

Hercules P02

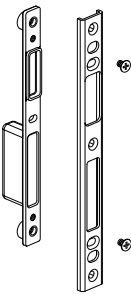
toebehoren ■ accessoires ■ accessories

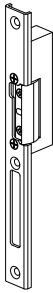
				
	<p>A-BS-251</p> <p>Slotplaat onder/boven 5.5mm Gache haut/basse 5.5mm Lockplates above and below 5.5mm</p>	-ST 1 		
	<p>A-BS-252</p> <p>Deurkruk binnen met langschild Bequille interieure avec plaque longue Handle inside with long plate</p>	-ST 1 		
	<p>A-BS-253</p> <p>Deurkruk buiten met langschild Bequille exterieure avec plaque longue handle outside with long plate</p>	-ST 1 		
	<p>A-BS-254</p> <p>SKG binnenkruk Bequille interieure SKG SKG handle inside</p>	-ST 1 		
	<p>A-BS-255</p> <p>SKG deurkruk buiten Bequille exterieure SKG SKG handle outside</p>	-ST 1 		

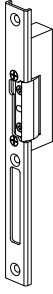



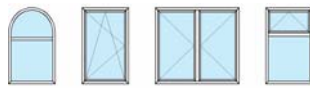





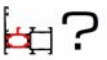
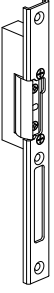

				
 <p>A-BS-256</p> <p>Slotplaat midden 8.5mm Gache central 8.5mm Central lockplate 8.5mm</p>	-ST 1			
 <p>A-BS-257</p> <p>Slotplaat onder/boven 8.5mm Gâche haut/basse 8.5mm Lockplates above and below 8.5mm</p>	-ST 1			
 <p>A-BS-258L</p> <p>Electrische slotplaat 5.5mm Gâche électrique 5.5mm Electric lockplates 5.5mm</p>	-ST 1			
 <p>A-BS-258R</p> <p>Electrische slotplaat 5.5mm Gâche électrique 5.5mm Electric lockplates 5.5mm</p>	-ST 1			
 <p>A-BS-259L</p> <p>Electrische slotplaat 8.5mm Gâche électrique 8.5mm Electric lockplates 8.5mm</p>	-ST 1			

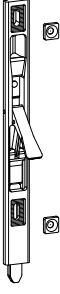

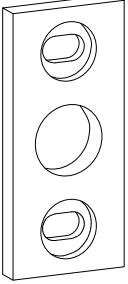
Hercules P02

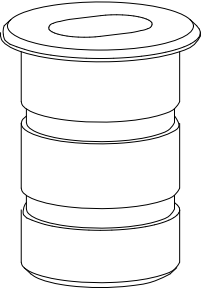

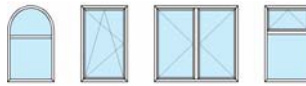

toebehoren ■ accessoires ■ accessories

			
 <p>A-BS-259R</p> <p>Electrische slotplaat 8.5mm Gache électrique 8.5mm Electric lockplates 8.5mm</p>	<p>-ST 1</p> 		
 <p>A-BS-260</p> <p>Deurgrendel voor 5 puntslot Verrou pour serrure 5-points Extended bolt for lock 5 points</p>	<p>-ST 1</p> 		
 <p>A-BS-261</p> <p>Sluitstukje voor A-BS-260 Gâche pour A-BS-260 Keeper for A-BS-260</p>	<p>-ST 1</p> 		
 <p>A-BS-262</p> <p>Bodemhuls voor deurgrendel Gâche encastrable pour verrou Ground sleeve</p>	<p>-ST 1</p> 		

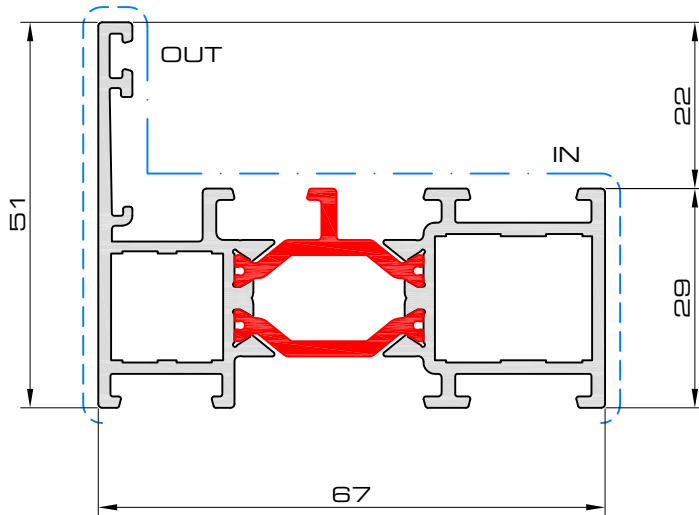







P-02-100

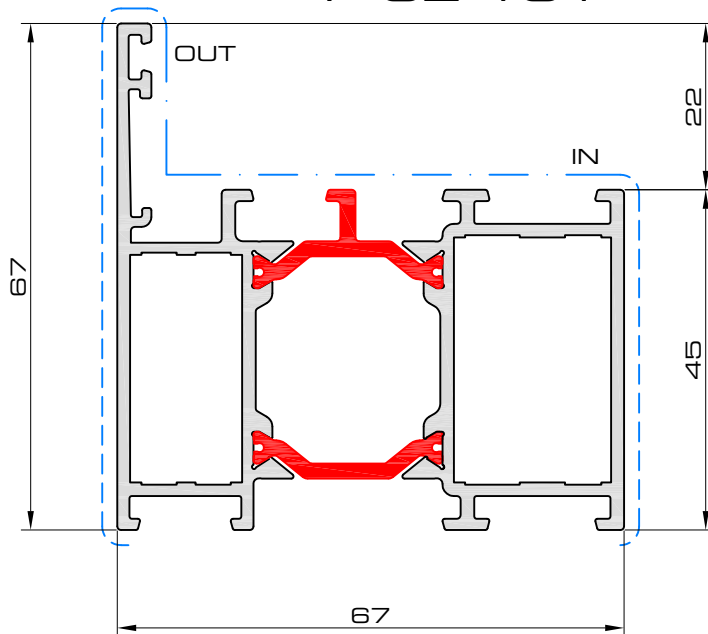

	OUT	IN
	A-PH-1415	A-PH-1621
	A-SH-1415	A-SH-1621
	A-TV-067	A-TV-001
	A-VH-1415	A-VH-1621
	$I_x = 25.14\text{cm}^4$ $I_y = 6.23\text{cm}^4$ $W_x = 6.78\text{cm}^3$ $W_y = 1.85\text{cm}^3$	

P-02-101



	OUT	IN
	A-PH-3015	A-PH-3221
	A-SH-3015	A-SH-3221
	A-TV-068	A-TV-002
	A-VH-3015	A-VH-3221
	$I_x = 32.07\text{cm}^4$ $I_y = 16.11\text{cm}^4$ $W_x = 9.97\text{cm}^3$ $W_y = 3.89\text{cm}^3$	

prof1

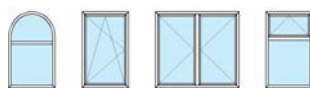



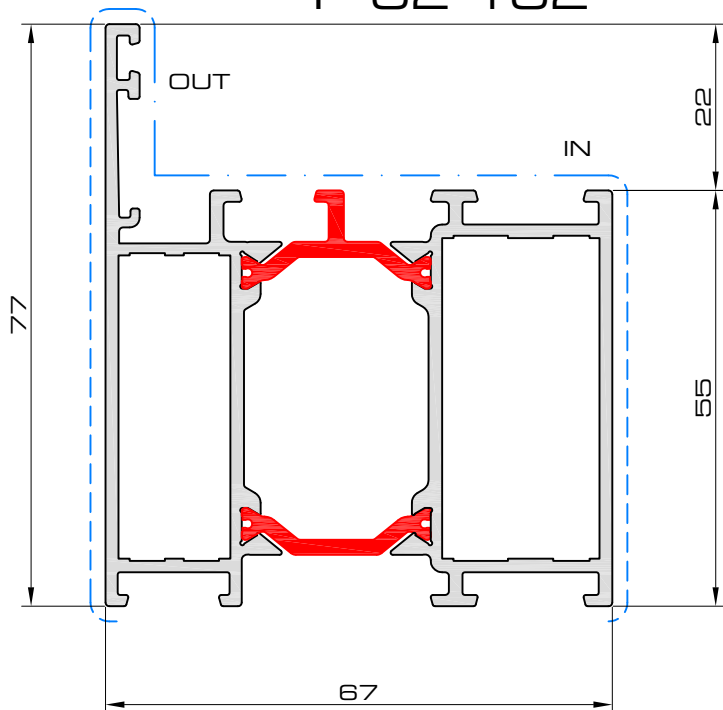

profielen ■ profils ■ profiles

Hercules P02





P-02-102

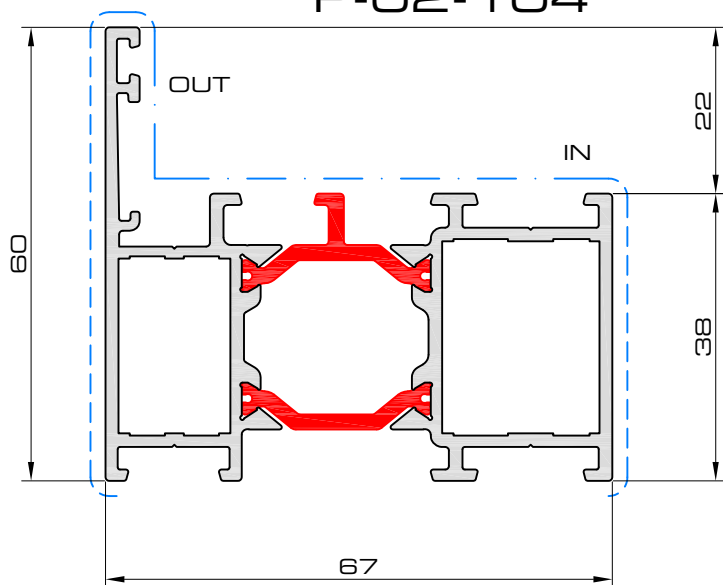

	OUT	IN
 P	A-PH-4015	A-PH-4221
 S	A-SH-4015	A-SH-4221
 TV	A-TV-069	A-TV-003
 V	A-VH-4015	A-VH-4221
	$I_x = 36.35\text{cm}^4$ $I_y = 25.81\text{cm}^4$ $W_x = 9.97\text{cm}^3$ $W_y = 5.57\text{cm}^3$	

P-02-104



	OUT	IN
 P	A-PH-2314	A-PH-2520
 S	A-SH-2314	A-SH-2520
 TV	-	-
 V	-	-
	$I_x = 29.06\text{cm}^4$ $I_y = 10.99\text{cm}^4$ $W_x = 7.9\text{cm}^3$ $W_y = 2.89\text{cm}^3$	

prof2



P-02-103

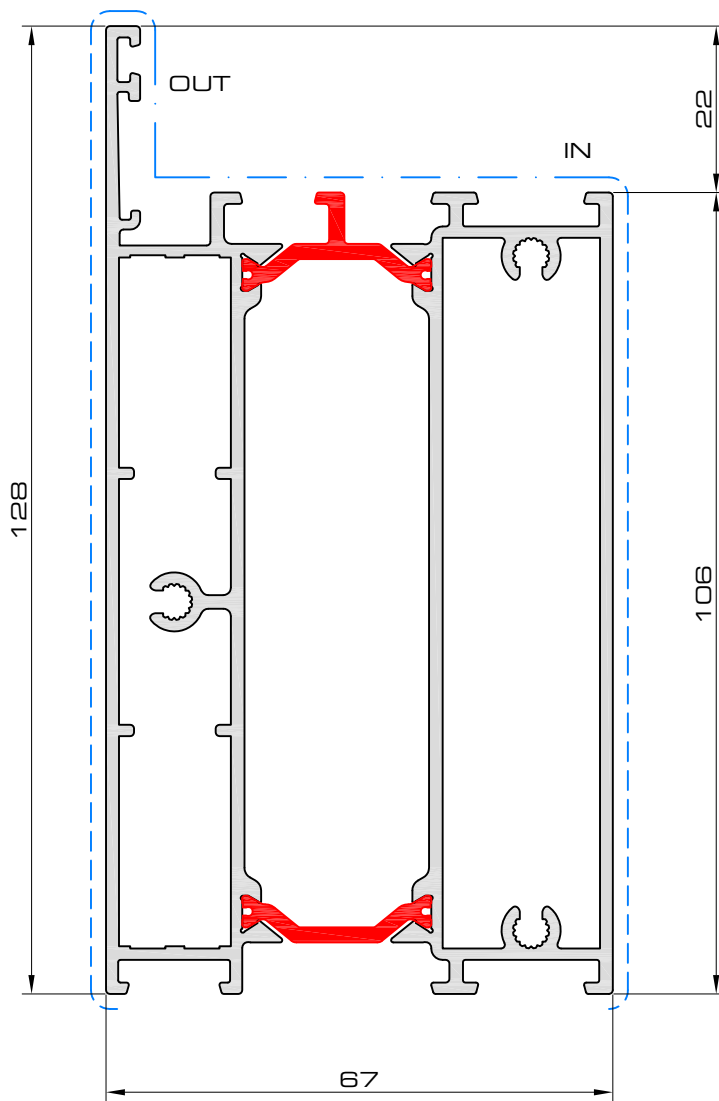

	$I_x = 62.25\text{cm}^4$
	$I_y = 138.44\text{cm}^4$
	$W_x = 17.29\text{cm}^3$
	$W_y = 19.24\text{cm}^3$

prof47



profielen ■ profils ■ profiles

Hercules P02

P-02-107

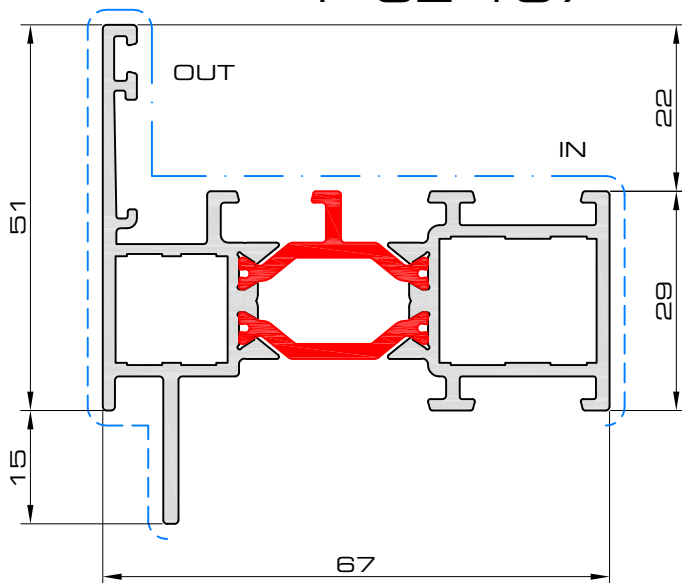

	OUT	IN
P	A-PH-1415	A-PH-1621
S	A-PH-1415	A-SH-1621
	-	-
	-	-
	$I_x = 26.46\text{cm}^4$ $I_y = 7.96\text{cm}^4$ $W_x = 6.88\text{cm}^3$ $W_y = 2.27\text{cm}^3$	

P-02-108

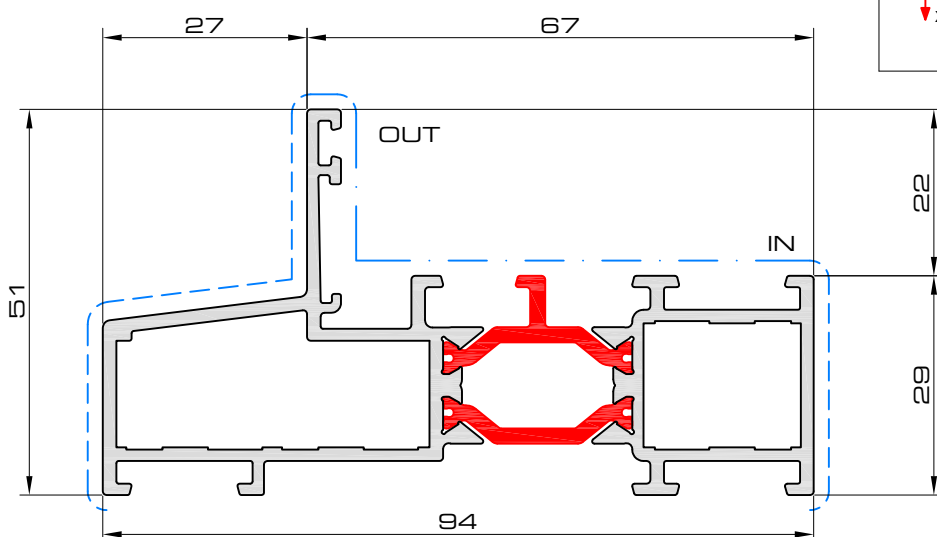

	OUT	IN
P	A-PH-1441	A-PH-1621
S	A-SH-1441	A-SH-1621
	$I_x = 48.46\text{cm}^4$ $I_y = 7.15\text{cm}^4$ $W_x = 10.21\text{cm}^3$ $W_y = 2.1\text{cm}^3$	





prof53

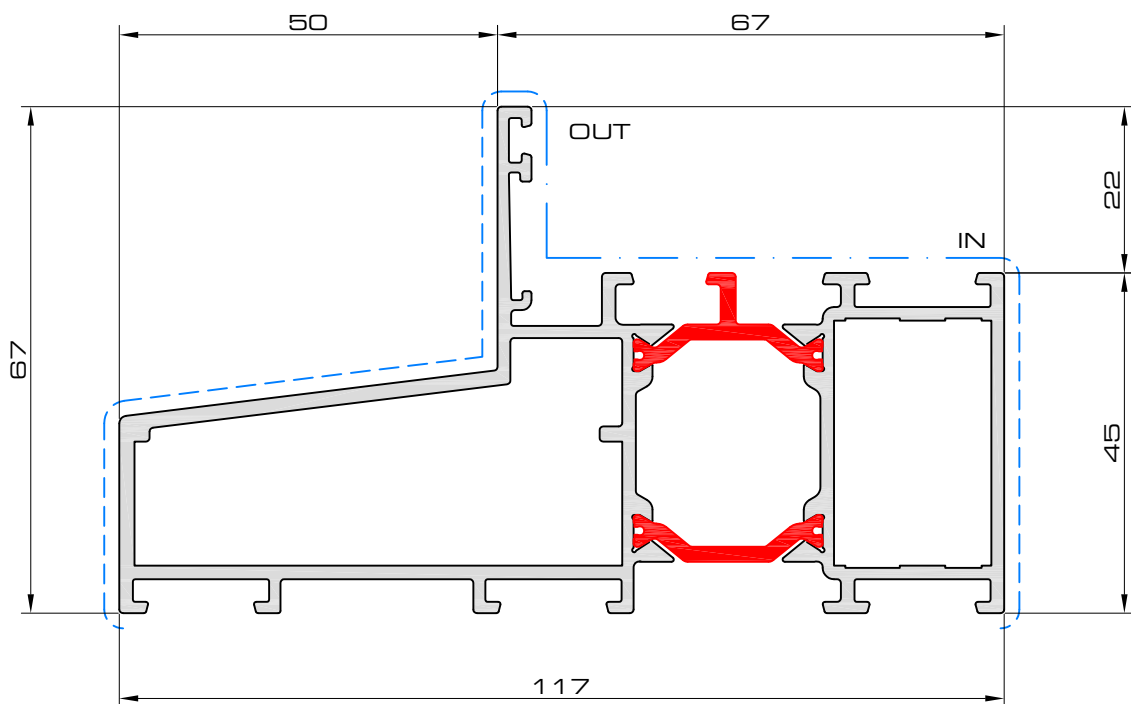

P-02-109



OUT IN

	A-PH-1665	A-PH-3221
	A-SH-1665	A-SH-3221
	-	-
	A-VH-1664	A-VH-3221
	$I_x = 100.51\text{cm}^4$ $I_y = 20.78\text{cm}^4$ $W_x = 16.16\text{cm}^3$ $W_y = 4.69\text{cm}^3$	

prof3

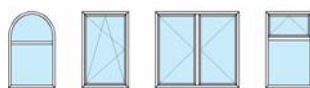

P-02-110

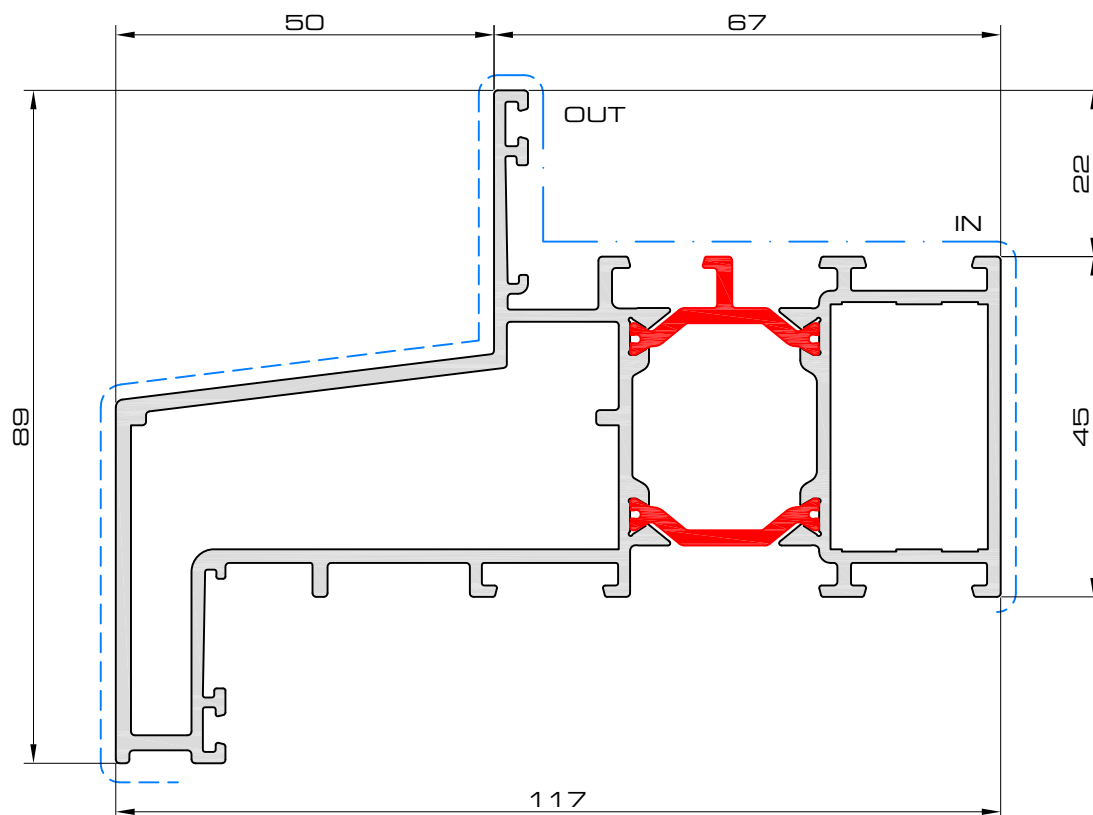

OUT IN

	A-PH-1665	A-PH-3221
	A-SH-1663	A-SH-3221
	-	-
	A-VH-1664	A-VH-3221
	$I_x = 127.52\text{cm}^4$ $I_y = 33.03\text{cm}^4$ $W_x = 20.89\text{cm}^3$ $W_y = 6.81\text{cm}^3$	



P-02-111

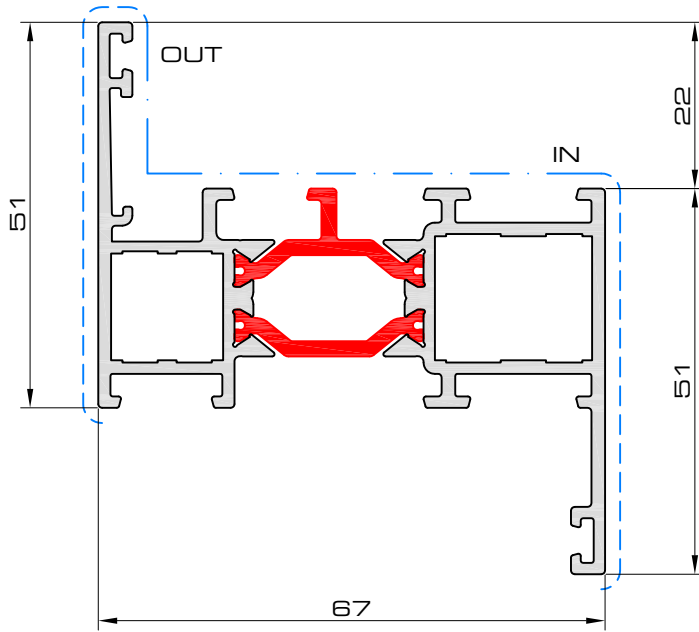

OUT IN

	A-PH-1415	A-PH-1621
	A-SH-1415	A-SH-1621
	A-TV-067	A-TV-001
	A-VH-1415	A-VH-1621

	$I_x = 30.72\text{cm}^4$
	$I_y = 10.28\text{cm}^4$
	$W_x = 9.16\text{cm}^3$
	$W_y = 2.81\text{cm}^3$

P-02-113

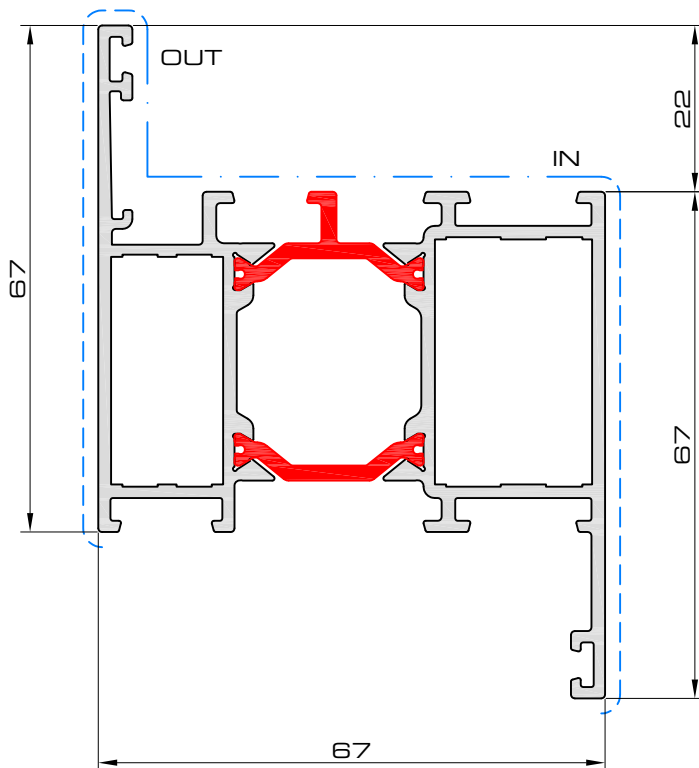

OUT IN

	A-PH-3015	A-PH-3221
	A-SH-3015	A-SH-3221
	A-TV-068	A-TV-002
	A-VH-3015	A-VH-3221





	$I_x = 37.65\text{cm}^4$
	$I_y = 22.71\text{cm}^4$
	$W_x = 11.14\text{cm}^3$
	$W_y = 5.10\text{cm}^3$

prof26

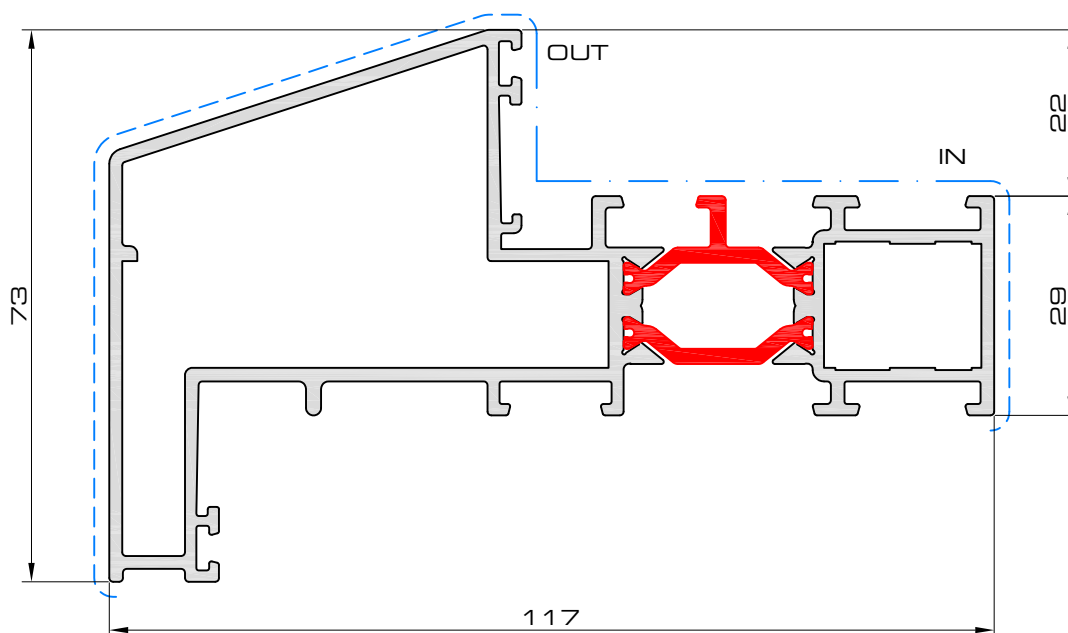

P-02-1 15







	OUT	IN
 P	A-PH-1464	A-PH-1621
 S	A-SH-1464	A-SH-1621
	-	-
 V	-	-
	$I_x = 110.94\text{cm}^4$ $I_y = 23.2\text{cm}^4$ $W_x = 17.12\text{cm}^3$ $W_y = 6.26\text{cm}^3$	

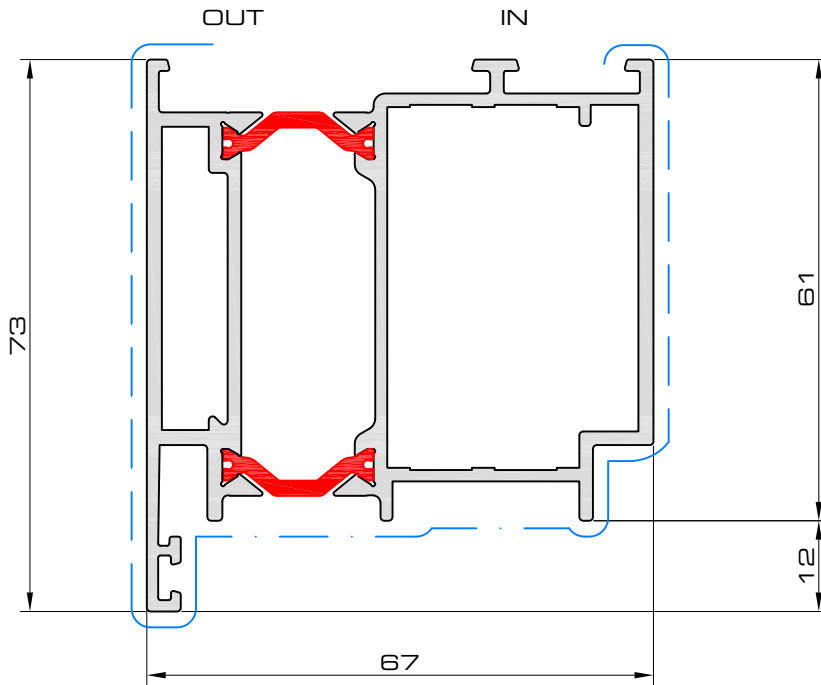







P-02-124

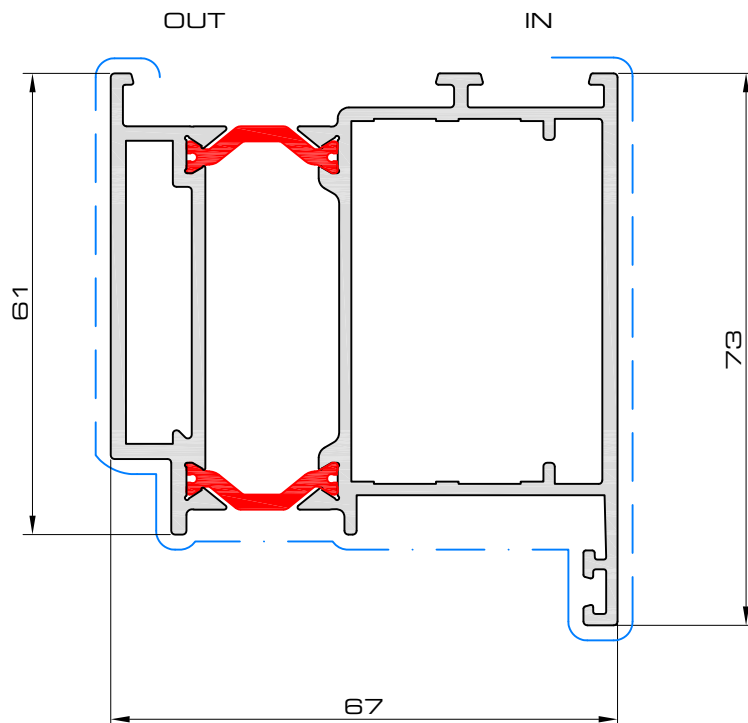

	OUT	IN
 P	A-PH-4006	A-PH-4725
 S	-	-
 H	-	-
 V	-	-
	$I_x = 38.91\text{cm}^4$ $I_y = 28.73\text{cm}^4$ $W_x = 10.18\text{cm}^3$ $W_y = 7.05\text{cm}^3$	

P-02-125



	OUT	IN
 P	A-PH-4006	A-PH-4725
 S	-	-
 H	-	-
 V	-	-
	$I_x = 39.57\text{cm}^4$ $I_y = 28.13\text{cm}^4$ $W_x = 11.54\text{cm}^3$ $W_y = 6.84\text{cm}^3$	

prof28

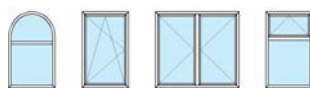

profielen ■ profils ■ profiles

Hercules P02

P-02-200

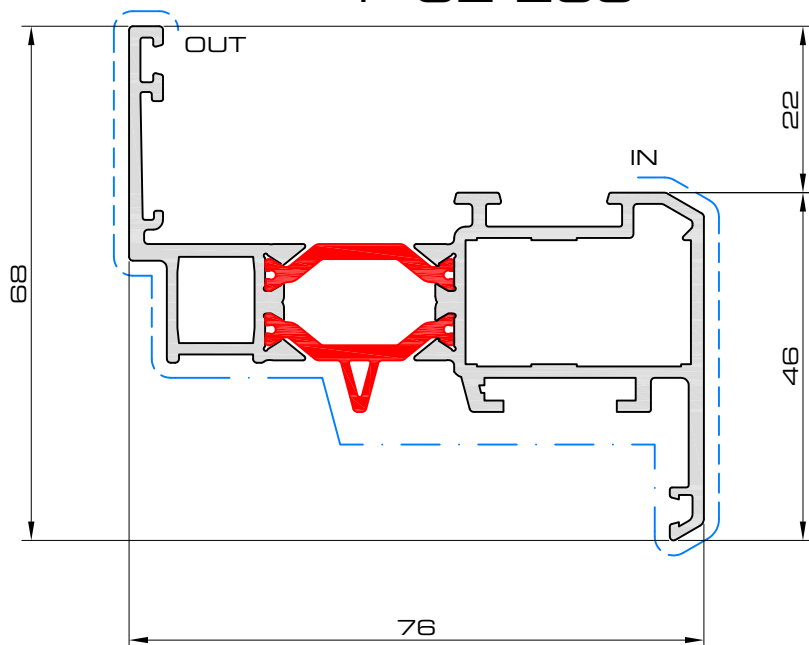

	OUT	IN
P	A-PH-1110	A-PH-1630
S	A-SH-1110	A-SH-1630
H	-	-
V	A-VH-1110	A-VH-1630
	$I_x = 35.01\text{cm}^4$ $I_y = 8.41\text{cm}^4$ $W_x = 8.75\text{cm}^3$ $W_y = 2.4\text{cm}^3$	

P-02-201

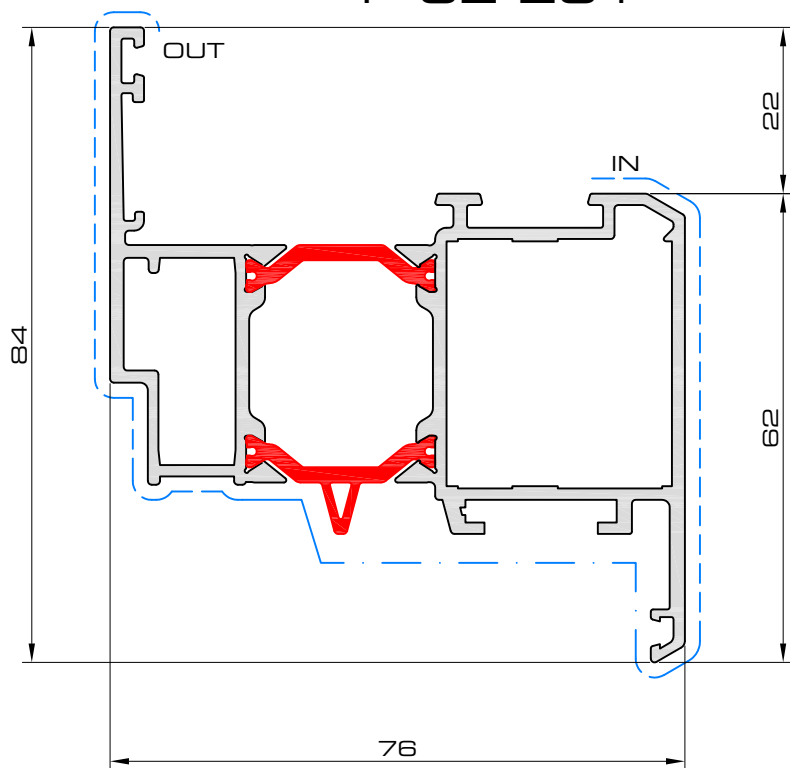





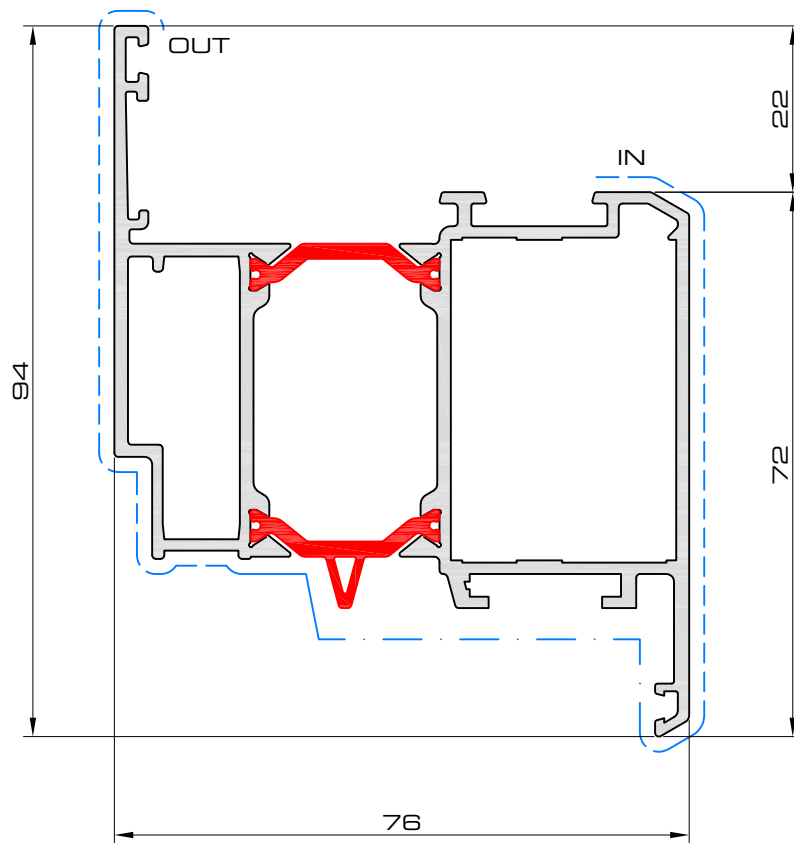

	OUT	IN
P	A-PH-2710	A-PH-3230
S	A-SH-2710	A-SH-3230
H	-	-
V	-	-
	$I_x = 45.18\text{cm}^4$ $I_y = 19.81\text{cm}^4$ $W_x = 11.81\text{cm}^3$ $W_y = 4.62\text{cm}^3$	

prof4



P-02-202



	OUT	IN
 P	A-PH-3710	A-PH-4230
 S	A-SH-3710	A-SH-4230
 H	-	-
 V	-	-
	$I_x = 50.84\text{cm}^4$ $I_y = 30.73\text{cm}^4$ $W_x = 13.3\text{cm}^3$ $W_y = 6.42\text{cm}^3$	

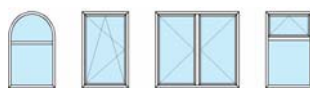



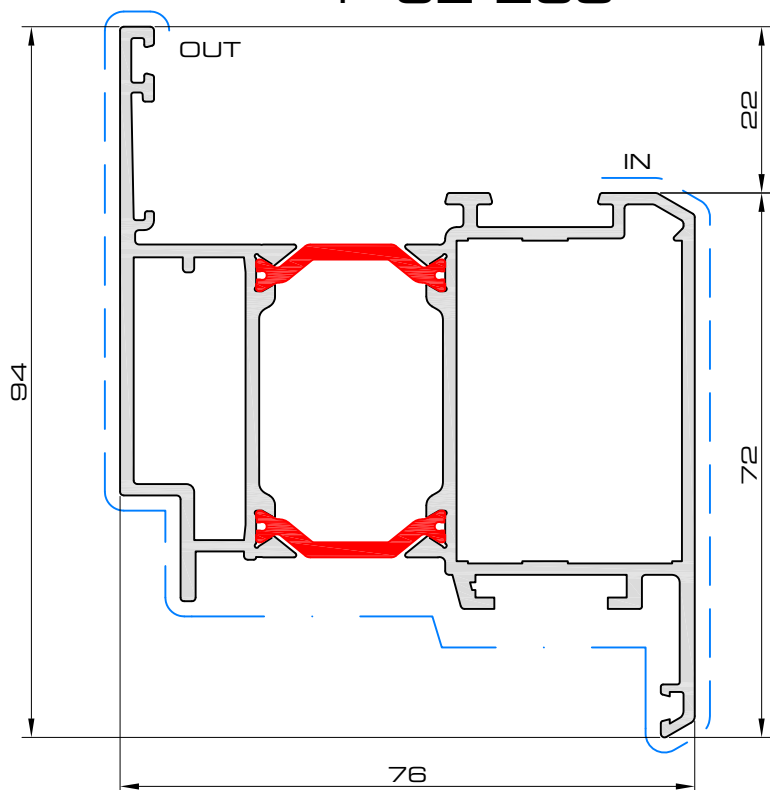

profielen ■ profils ■ profiles

Hercules P02





P-02-203

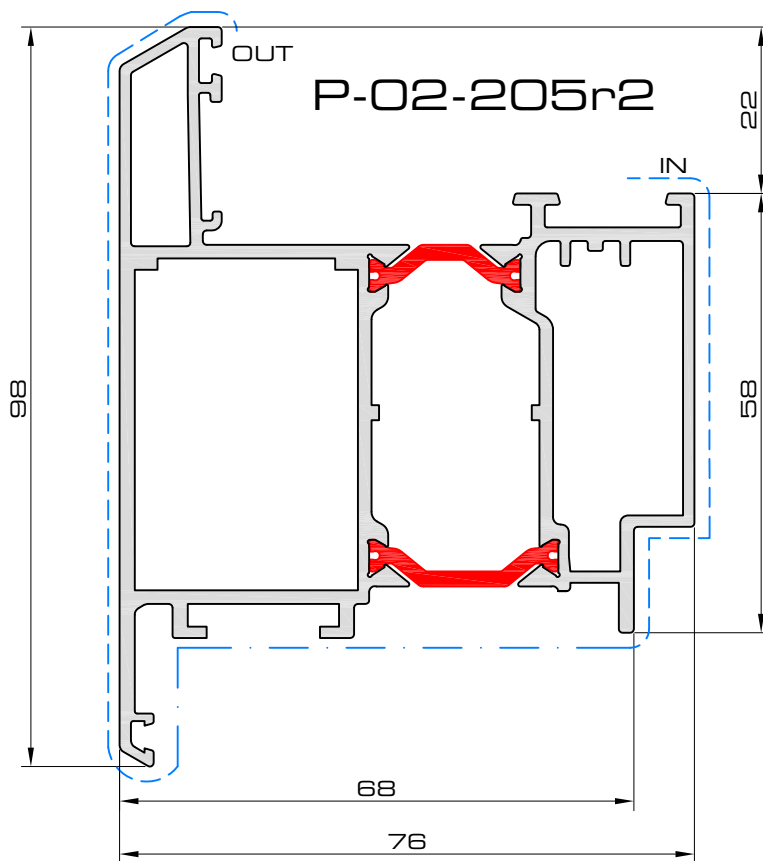
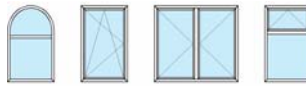

	OUT	IN
 P	A-PH-3706	A-PH-4230
 S	A-PH-3706	A-SH-4230
 H	-	-
 V	-	-
	$I_x = 52.1\text{cm}^4$ $I_y = 31.48\text{cm}^4$ $W_x = 13.4\text{cm}^3$ $W_y = 6.51\text{cm}^3$	

prof6



	OUT	IN
 P	A-PH-4229	A-PH-4206
 S	A-SH-4229	A-PH-4206
 H	-	-
 V	-	-
	$I_x = 56.42\text{cm}^4$ $I_y = 44.33\text{cm}^4$ $W_x = 12.93\text{cm}^3$ $W_y = 8.85\text{cm}^3$	

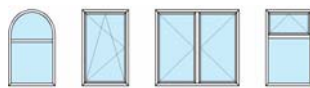

Hercules P02

profielen ■ profils ■ profiles

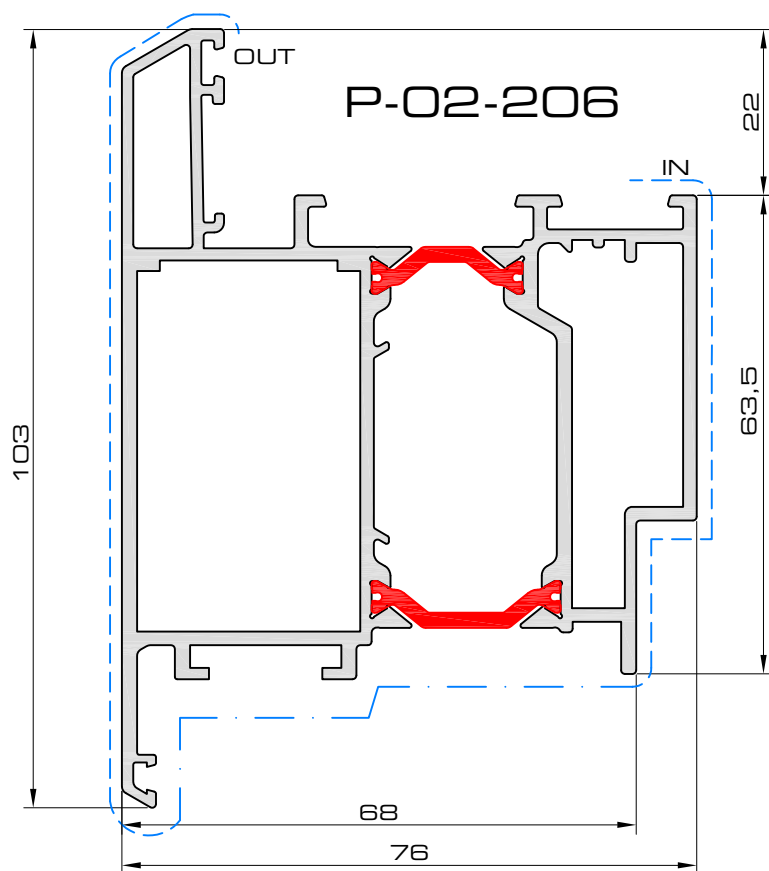

	OUT	IN
	A-PH-4730	A-PH-4707
	A-SH-4730	A-PH-4707
	-	-
	-	-
	$I_x = 61.51\text{cm}^4$ $I_y = 54.19\text{cm}^4$ $W_x = 14.38\text{cm}^3$ $W_y = 10.21\text{cm}^3$	

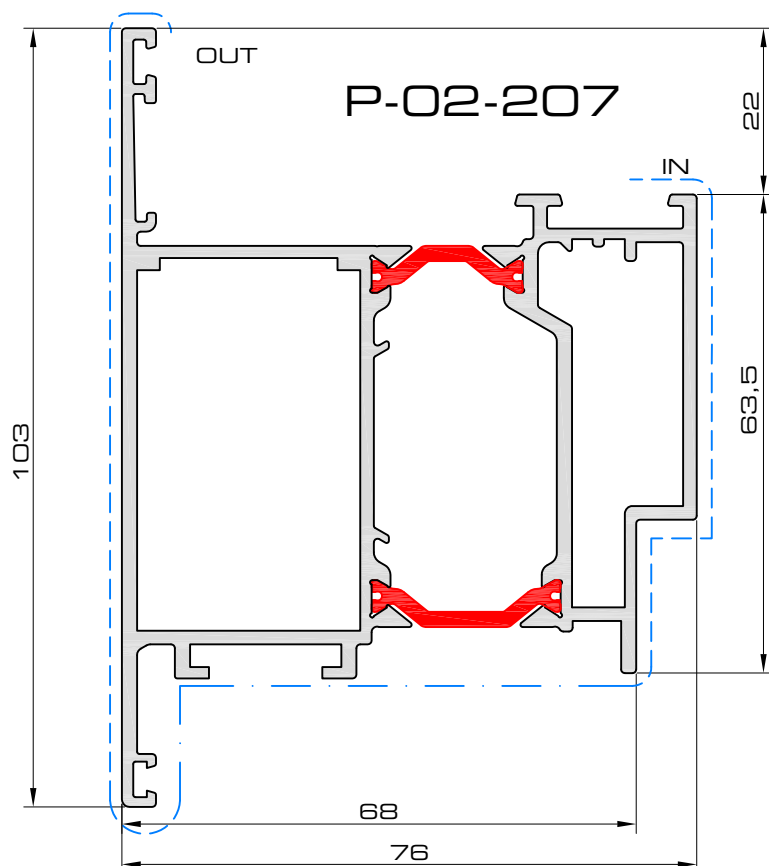

	OUT	IN
	A-PH-4730	A-PH-4707
	A-SH-4730	A-PH-4707
	-	-
	-	-
	$I_x = 60.11\text{cm}^4$ $I_y = 46.46\text{cm}^4$ $W_x = 14.44\text{cm}^3$ $W_y = 8.82\text{cm}^3$	

prof46



P-02-210

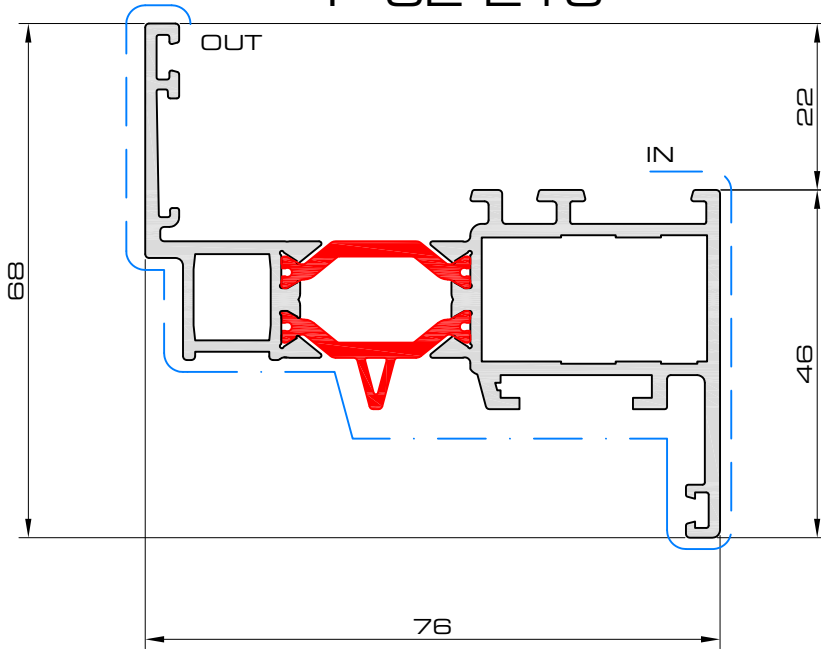

Variant! Planea

	OUT	IN
P	A-PH-1110	A-PH-1630
S	A-SH-1110	A-SH-1630
H	-	-
V	A-VH-1110	A-VH-1630
	$I_x = 35.84\text{cm}^4$ $I_y = 8.58\text{cm}^4$ $W_x = 8.84\text{cm}^3$ $W_y = 2.42\text{cm}^3$	

P-02-211

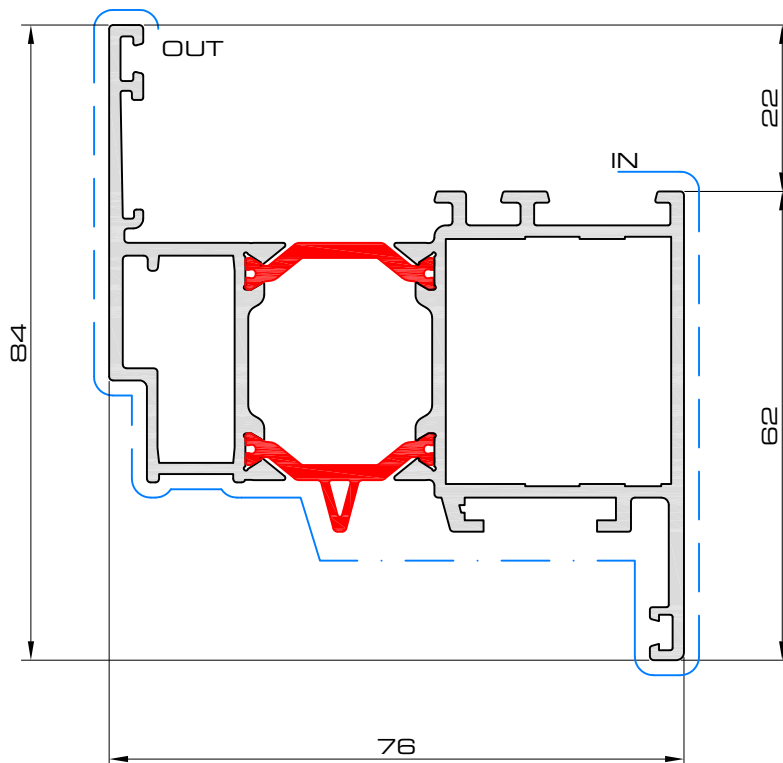

	OUT	IN
P	A-PH-2710	A-PH-3230
S	A-SH-2710	A-SH-3230
H	-	-
V	-	-
	$I_x = 46.08\text{cm}^4$ $I_y = 20.06\text{cm}^4$ $W_x = 11.91\text{cm}^3$ $W_y = 4.64\text{cm}^3$	

prof24

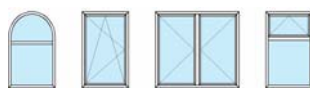

profielen ■ profils ■ profiles

Hercules P02

P-02-212

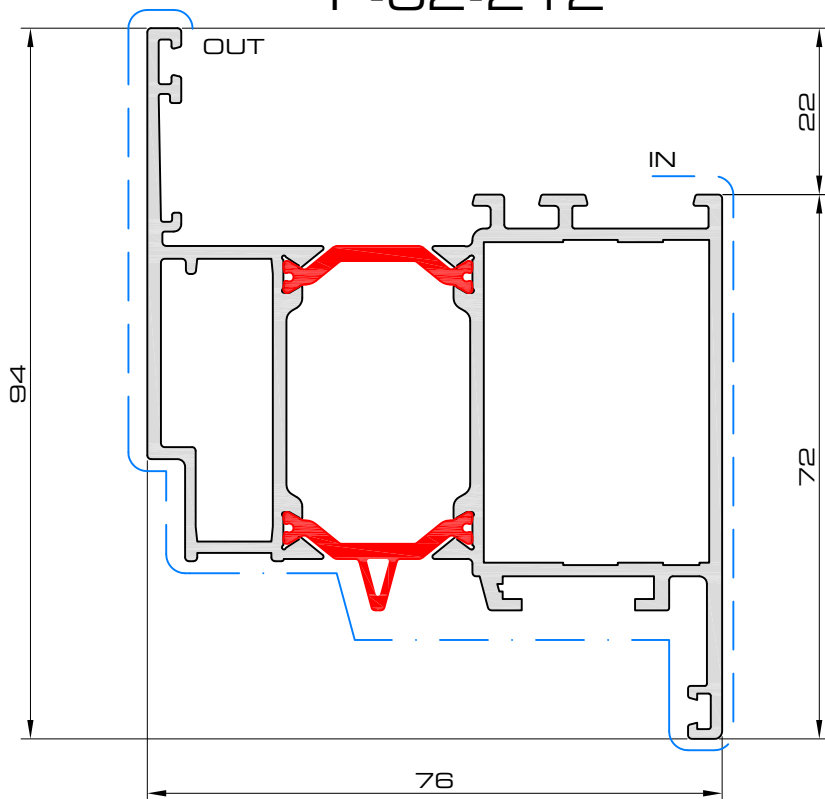

Variant! **Planea**

	OUT	IN
	A-PH-3710	A-PH-4230
	A-SH-3710	A-SH-4230
	-	-
	-	-
	$I_x = 51.83\text{cm}^4$ $I_y = 31.73\text{cm}^4$ $W_x = 13.54\text{cm}^3$ $W_y = 6.64\text{cm}^3$	

P-02-213

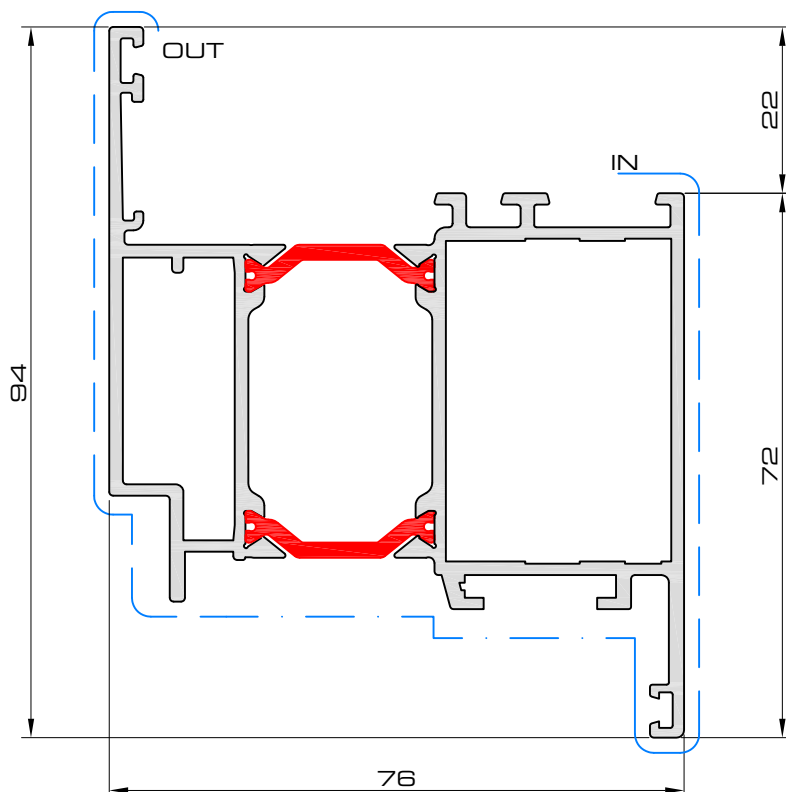





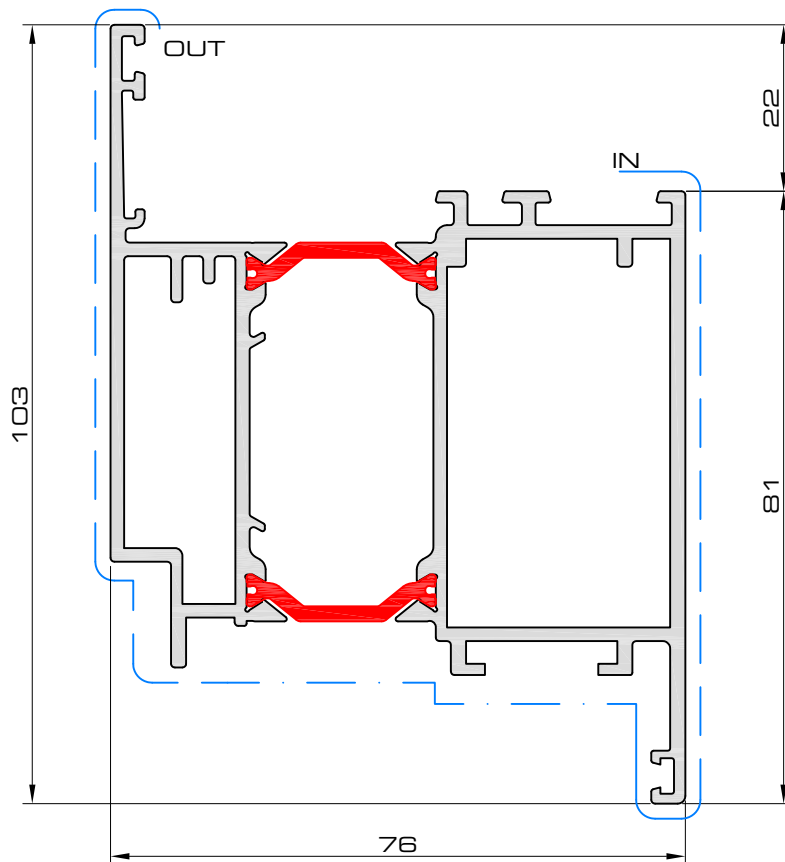

	OUT	IN
	A-PH-3706	A-PH-4230
	A-PH-3706	A-SH-4230
	-	-
	-	-
	$I_x = 53.14\text{cm}^4$ $I_y = 32.5\text{cm}^4$ $W_x = 13.85\text{cm}^3$ $W_y = 6.73\text{cm}^3$	

prof41



P-02-214



	OUT	IN
 P	A-PH-4207	A-PH-4730
 S	A-PH-4207	A-SH-4730
 V	-	-
 V	-	-
	$I_x = 63.05\text{cm}^4$ $I_y = 48.08\text{cm}^4$ $W_x = 16.53\text{cm}^3$ $W_y = 9.24\text{cm}^3$	

prof45

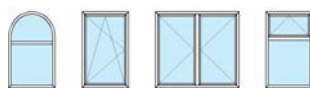





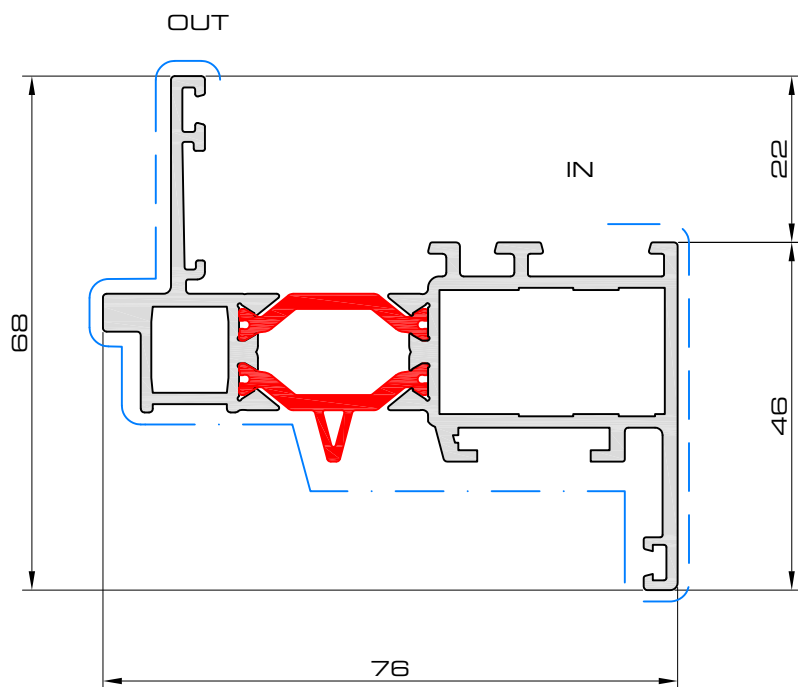

profielen ■ profils ■ profiles

Hercules P02

Variant!
Linea

P-02-220



	OUT	IN
 P	A-PH-1110	A-PH-1630
 S	A-SH-1110	A-SH-1630
 V	-	-
 V	A-VH-1110	A-VH-1630
	$I_x = 33.82\text{cm}^4$ $I_y = 8.58\text{cm}^4$ $W_x = 8.32\text{cm}^3$ $W_y = 2.43\text{cm}^3$	

prof34

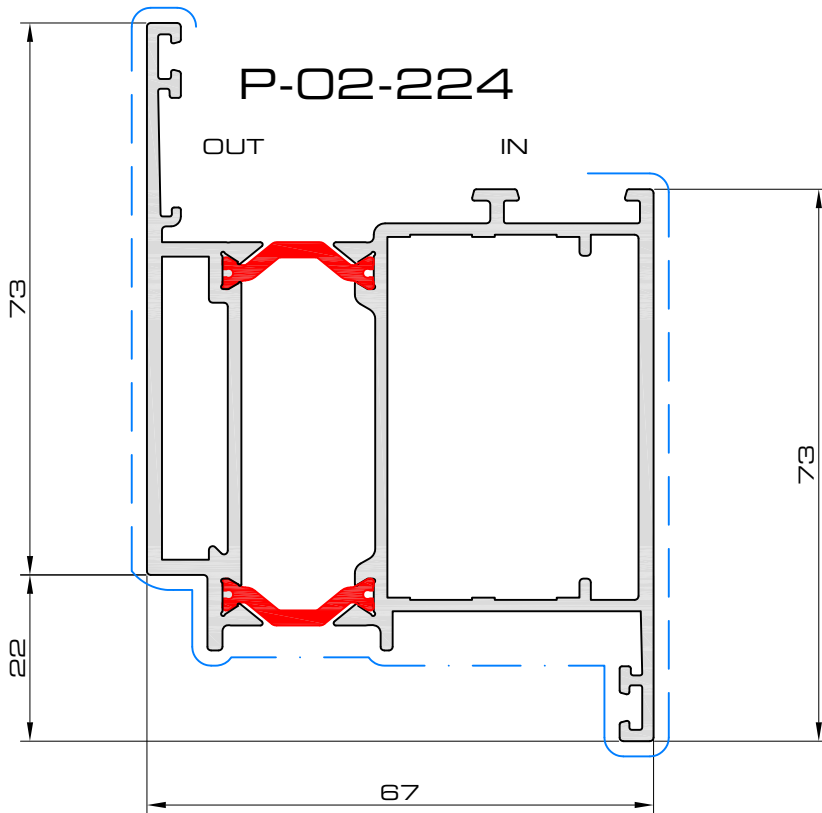

	OUT	IN
P	A-PH-4006	A-PH-4725
S	-	-
H	-	-
V	-	-
	$I_x = 44.25\text{cm}^4$ $I_y = 37.28\text{cm}^4$ $W_x = 12.11\text{cm}^3$ $W_y = 7.34\text{cm}^3$	

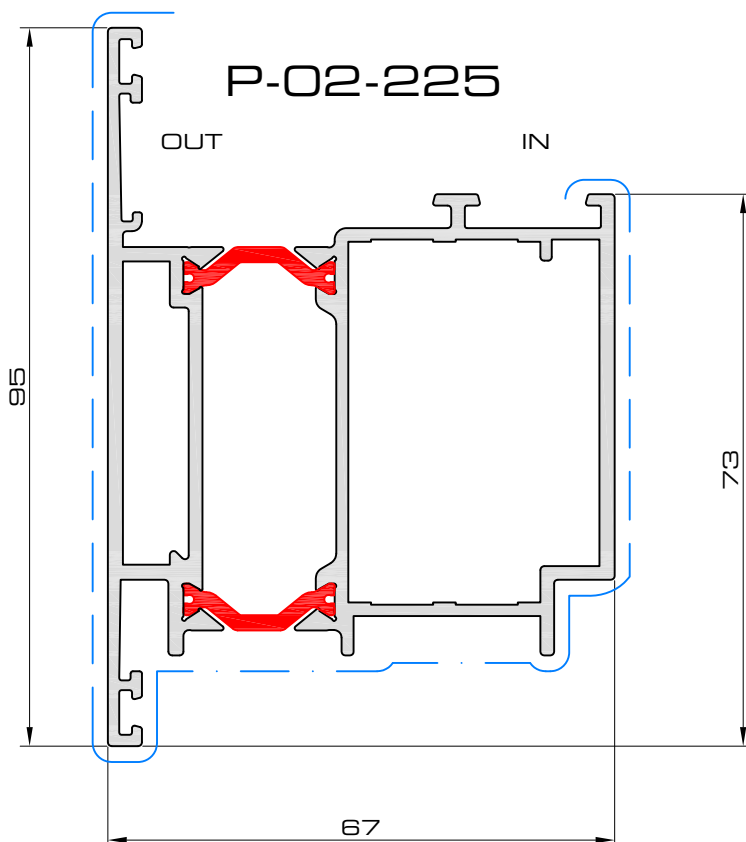

	OUT	IN
P	A-PH-4006	A-PH-4725
S	-	-
H	-	-
V	-	-
	$I_x = 42.49\text{cm}^4$ $I_y = 36.06\text{cm}^4$ $W_x = 10.58\text{cm}^3$ $W_y = 7.43\text{cm}^3$	

prof29



profielen ■ profils ■ profiles

Hercules P02

Variant! PVC-nut

P-02-230

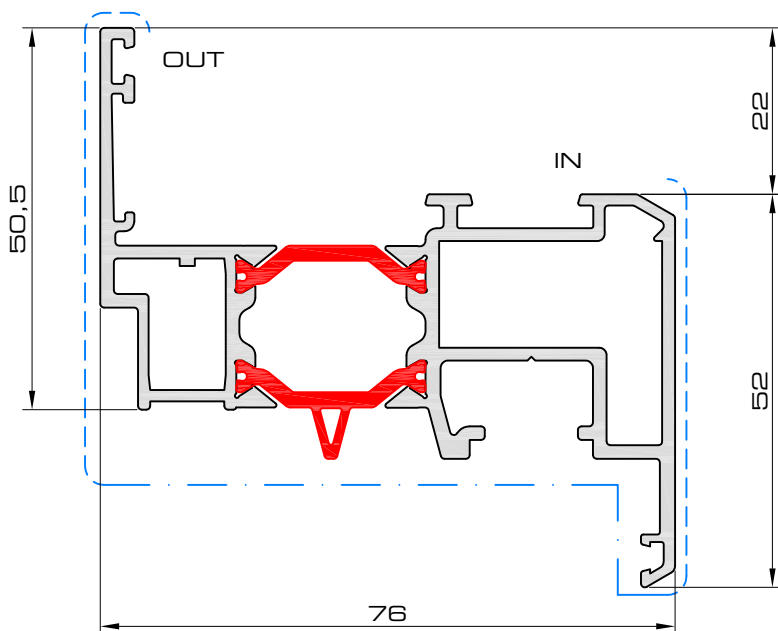

	OUT	IN
P	A-PH-1610	A-PH-1430
S	-	-
H	-	-
V	-	-
	$I_x = 40.56\text{cm}^4$ $I_y = 11.85\text{cm}^4$ $W_x = 10.17\text{cm}^3$ $W_y = 3.12\text{cm}^3$	

P-02-231

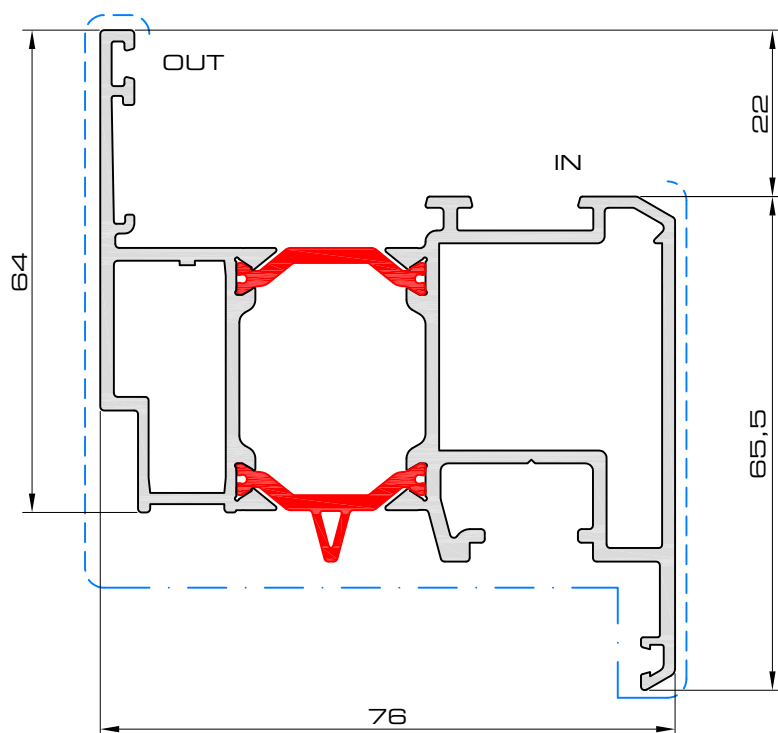

	OUT	IN
P	A-PH-3010	A-PH-2730
S	-	-
H	-	-
V	-	-
	$I_x = 48.14\text{cm}^4$ $I_y = 23.25\text{cm}^4$ $W_x = 12.33\text{cm}^3$ $W_y = 5.19\text{cm}^3$	

prof27

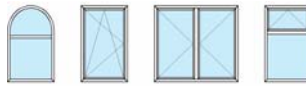

Variant! PVC-nut

P-02-240

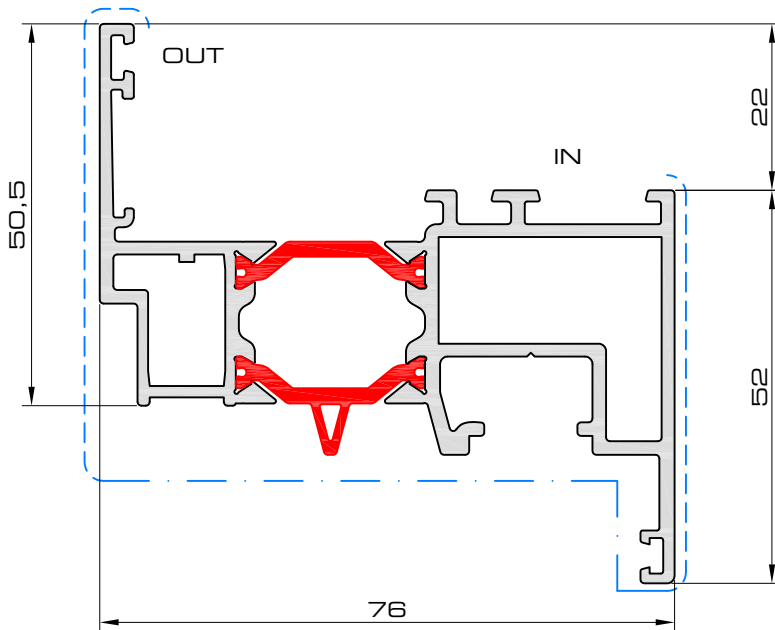

	OUT	IN
P	A-PH-1610	A-PH-1430
S	-	-
B	-	-
V	-	-
	$I_x = 41.37\text{cm}^4$ $I_y = 12.22\text{cm}^4$ $W_x = 10.24\text{cm}^3$ $W_y = 3.22\text{cm}^3$	

P-02-241

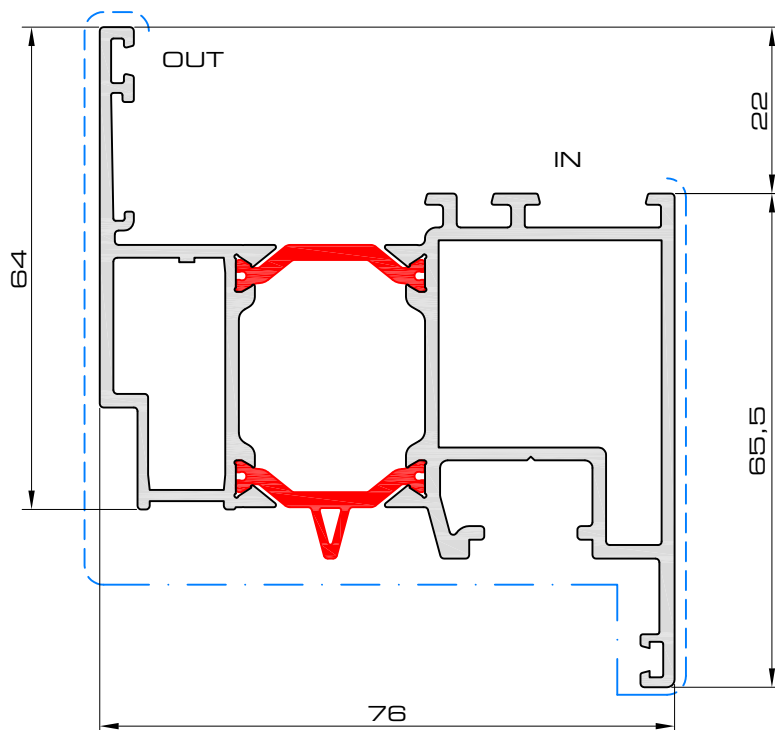

	OUT	IN
P	A-PH-3010	A-PH-2730
S	-	-
B	-	-
V	-	-
	$I_x = 48.99\text{cm}^4$ $I_y = 23.91\text{cm}^4$ $W_x = 12.41\text{cm}^3$ $W_y = 5.34\text{cm}^3$	

prof51



profielen ■ profils ■ profiles

Hercules P02

Variant! PVC-nut

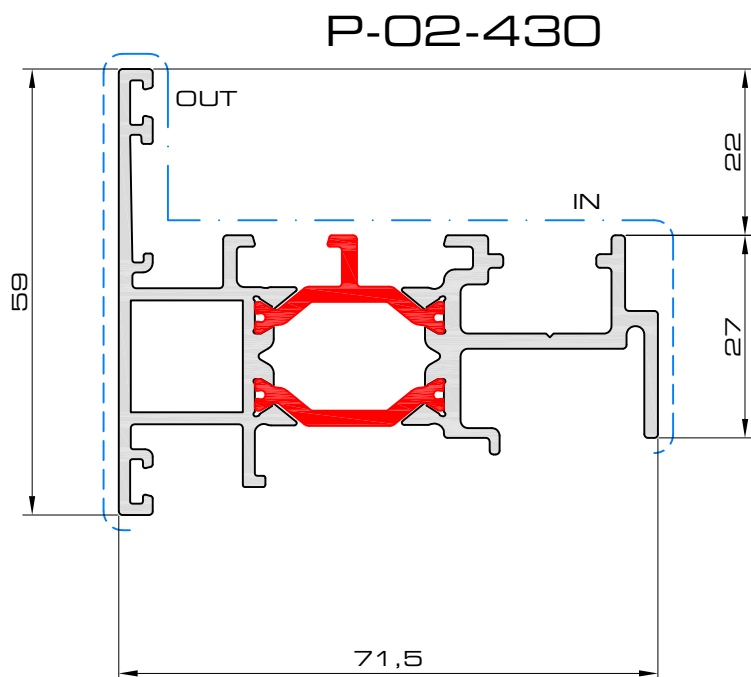





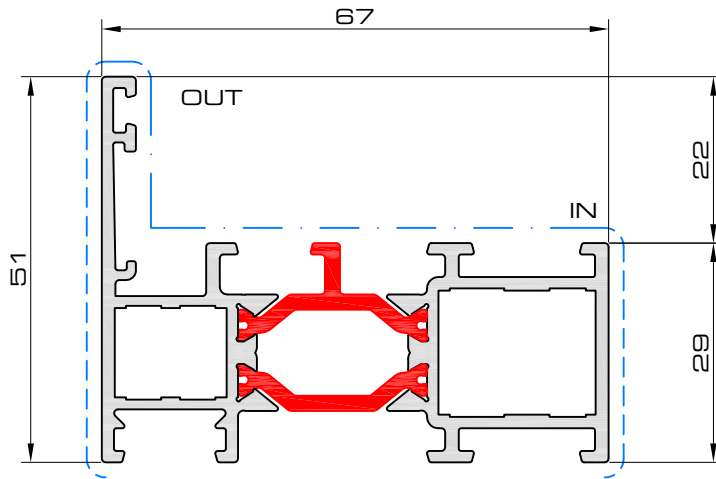

	$I_x = 28.50\text{cm}^4$
	$I_y = 6.98\text{cm}^4$
	$W_x = 6.76\text{cm}^3$
	$W_y = 2.02\text{cm}^3$

prof42









P-02-116

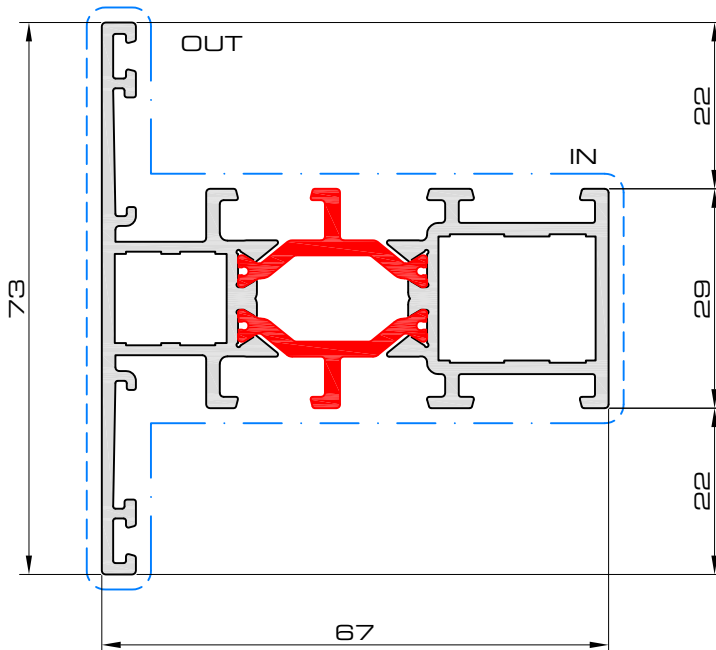

	OUT	IN
 P	A-PH-1115	A-PH-1621
 S	-	A-SH-1621
 TV	A-TV-064	A-TV-001
	A-TV-057	A-TV-005
 V	-	A-VH-1621
 VT	A-VT-1115	A-VT-1621
	$I_x = 25.15\text{cm}^4$ $I_y = 6.12\text{cm}^4$ $W_x = 6.79\text{cm}^3$ $W_y = 1.83\text{cm}^3$	

P-02-300



	OUT	IN
 P	A-PH-1115	A-PH-1621
 S	-	A-SH-1621
 TV	A-TV-064	A-TV-001
	A-TV-057	A-TV-005
 V	-	A-VH-1621
 VT	A-VT-1115	A-VT-1621
	$I_x = 28.84\text{cm}^4$ $I_y = 10.22\text{cm}^4$ $W_x = 7.2\text{cm}^3$ $W_y = 2.8\text{cm}^3$	

prof7



profielen ■ profils ■ profiles

Hercules P02

P-02-301

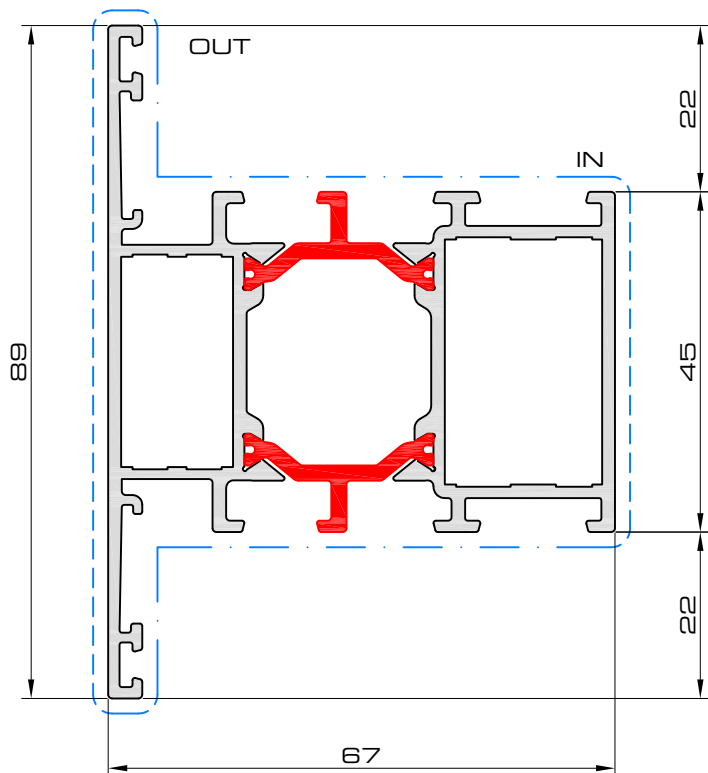

	OUT	IN
P	A-PH-2715	A-PH-3221
S	-	A-SH-3221
TV	A-TV-065	A-TV-002
V	-	A-VH-3221
V	A-VT-2715L	A-VT-3221L
V	A-VT-2715R	A-VT-3221R
	$I_x = 35.97\text{cm}^4$ $I_y = 22.63\text{cm}^4$ $W_x = 9.2\text{cm}^3$ $W_y = 5.09\text{cm}^3$	

P-02-302

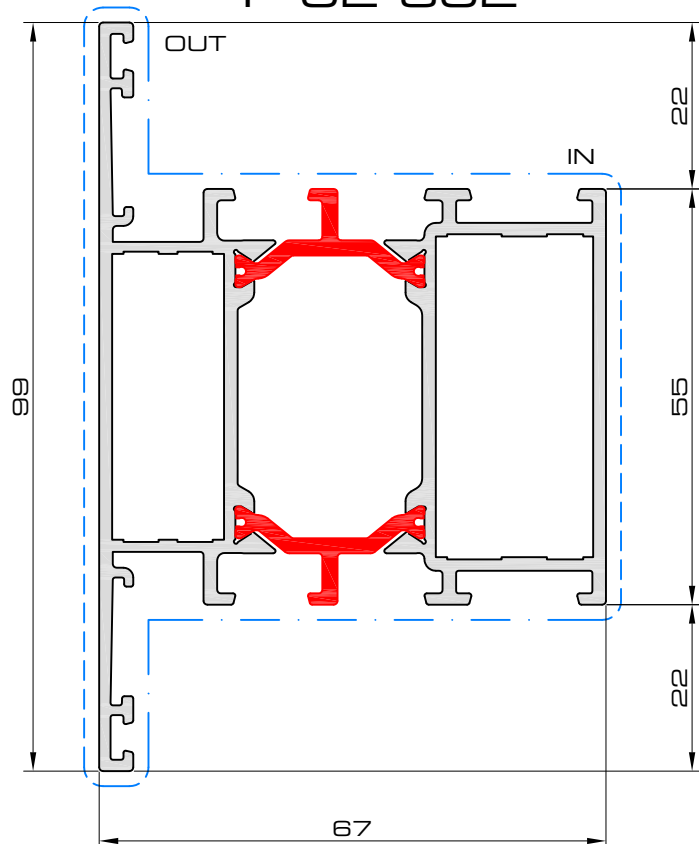

	OUT	IN
P	A-PH-3715	A-PH-4221
S	-	A-SH-4221
TV	A-TV-066	A-TV-003
V	-	A-VH-4221
	$I_x = 40.34\text{cm}^4$ $I_y = 34.25\text{cm}^4$ $W_x = 10.43\text{cm}^3$ $W_y = 6.92\text{cm}^3$	

prof8



P-02-303

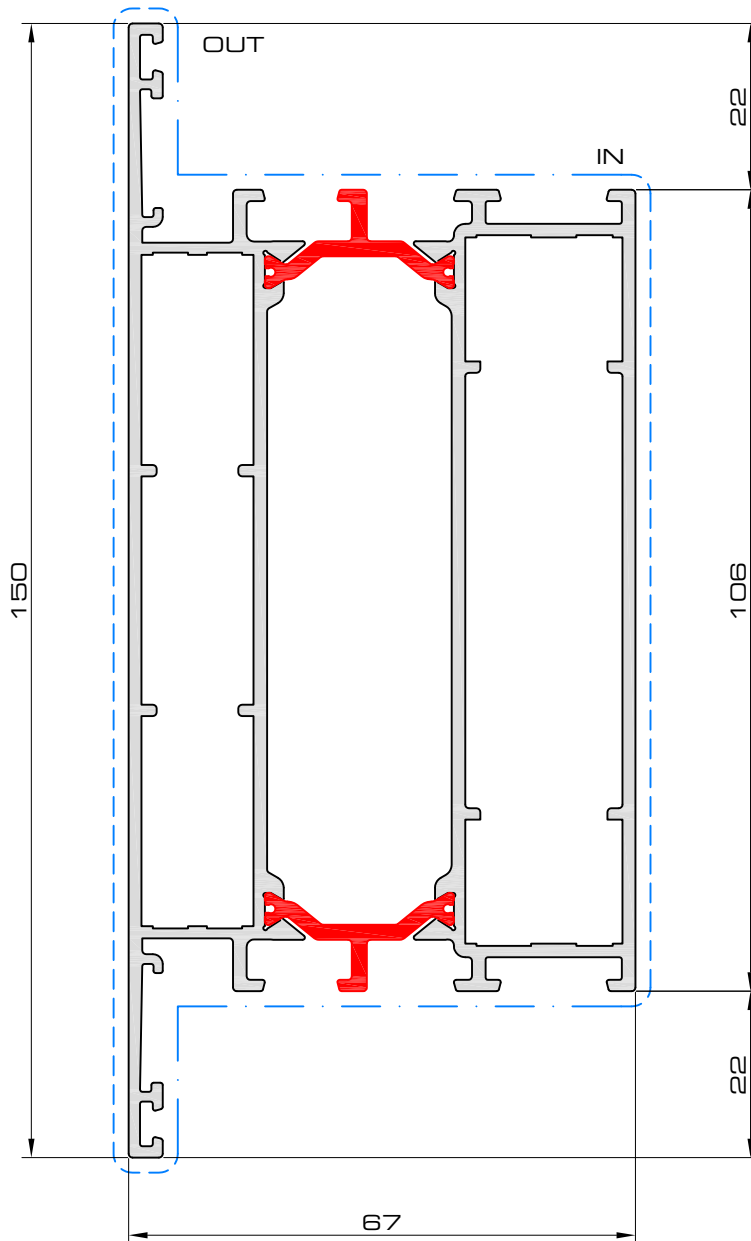

	OUT	IN
	-	-
	-	-
	A-TV-065	A-TV-001
	-	-
	$I_x = 63.23\text{cm}^4$ $I_y = 154.78\text{cm}^4$ $W_x = 17.03\text{cm}^3$ $W_y = 20.64\text{cm}^3$	







prof9

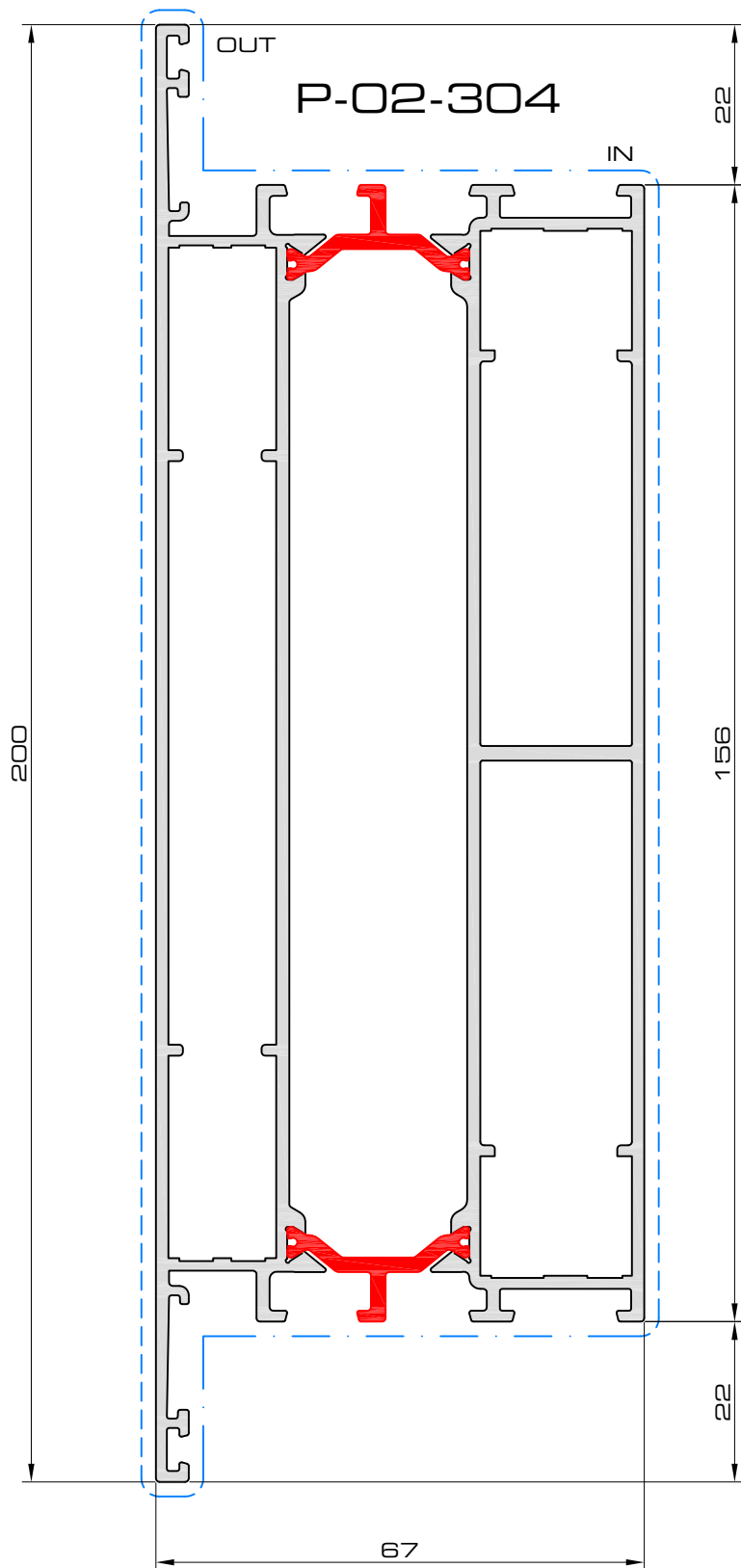

Hercules P02

profielen ■ profils ■ profiles







	OUT	IN
	-	-
	-	-
	A-TV-065	A-TV-001
	A-TV-065	-
	-	-
	$I_x = 87.83\text{cm}^4$ $I_y = 404.74\text{cm}^4$ $W_x = 24.3\text{cm}^3$ $W_y = 40.47\text{cm}^3$	

prof17

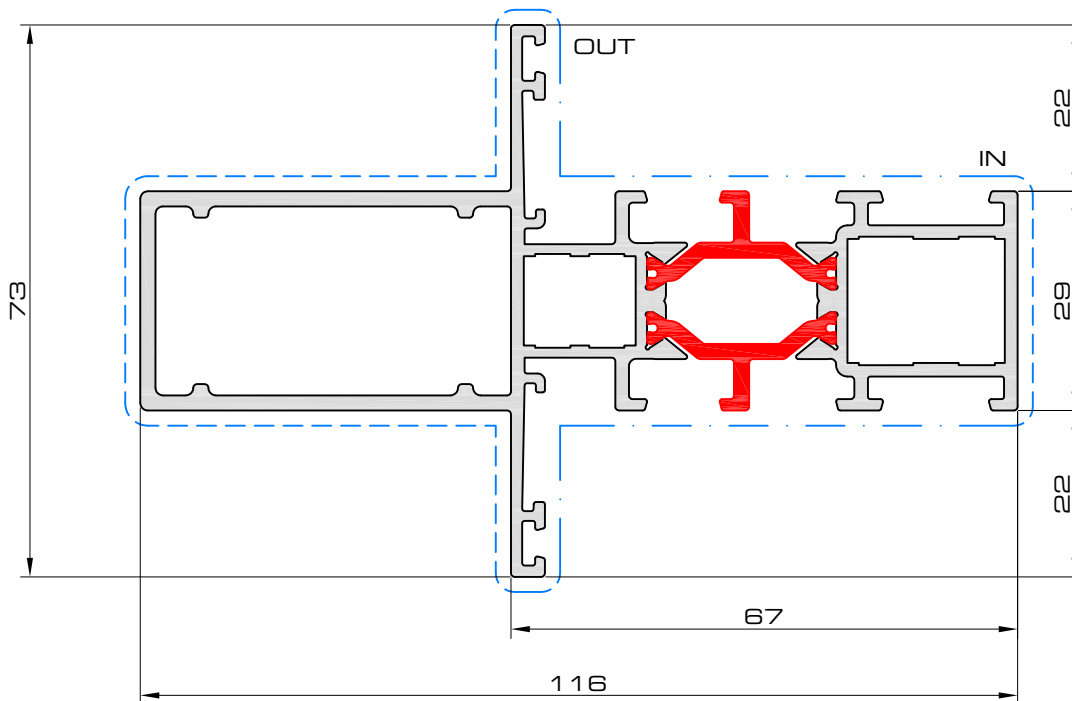

P-02-305



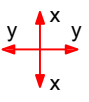

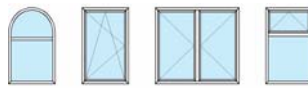

	OUT	IN
	-	-
	-	-
	A-TV-064	A-TV-001
	A-TV-057	A-TV-005
	-	-
	$I_x = 88.41\text{cm}^4$ $I_y = 14.28\text{cm}^4$ $W_x = 14.88\text{cm}^3$ $W_y = 3.91\text{cm}^3$	

prof10

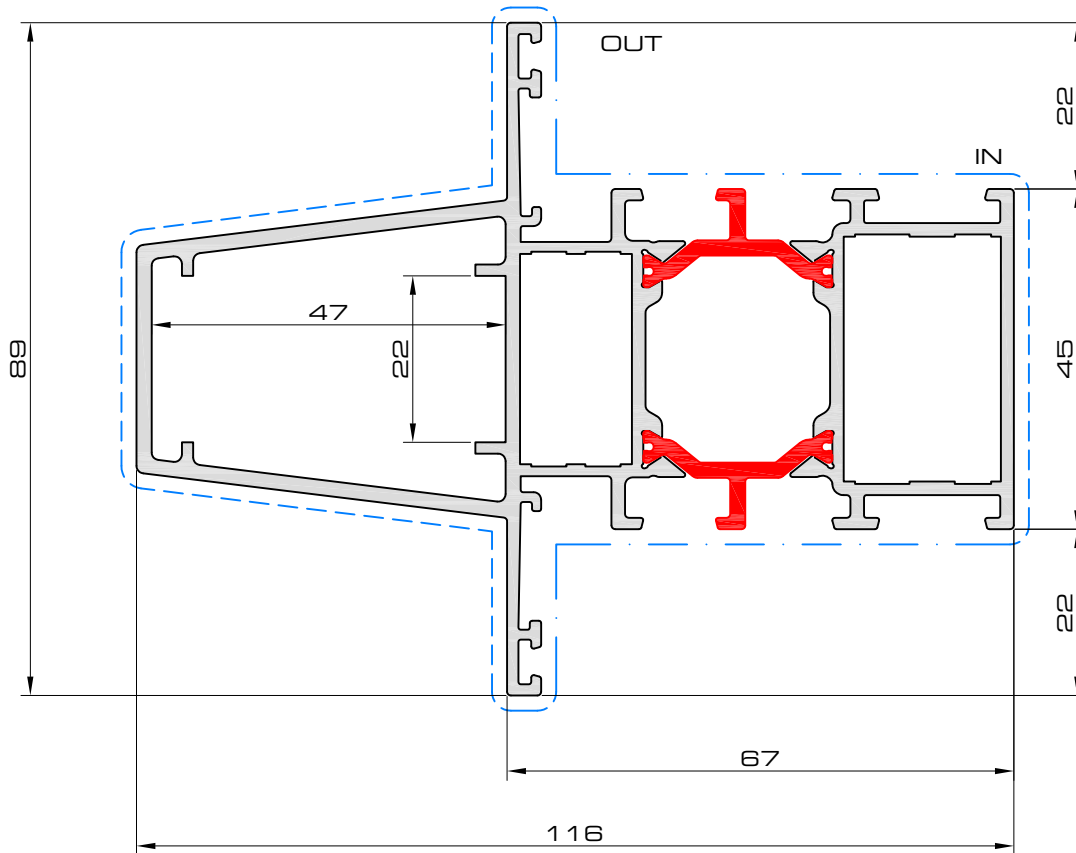

P-02-306



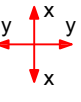



	OUT	IN
 P	-	-
 S	-	-
 TV	A-TV-065	A-TV-002
 V	-	-
	$I_x = 103.34\text{cm}^4$ $I_y = 29.2\text{cm}^4$ $W_x = 17.42\text{cm}^3$ $W_y = 6.56\text{cm}^3$	

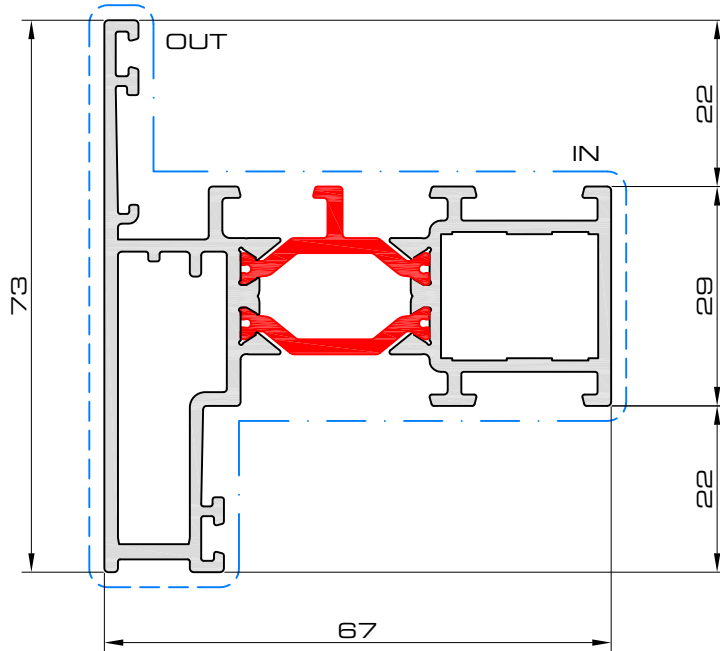





P-02-309

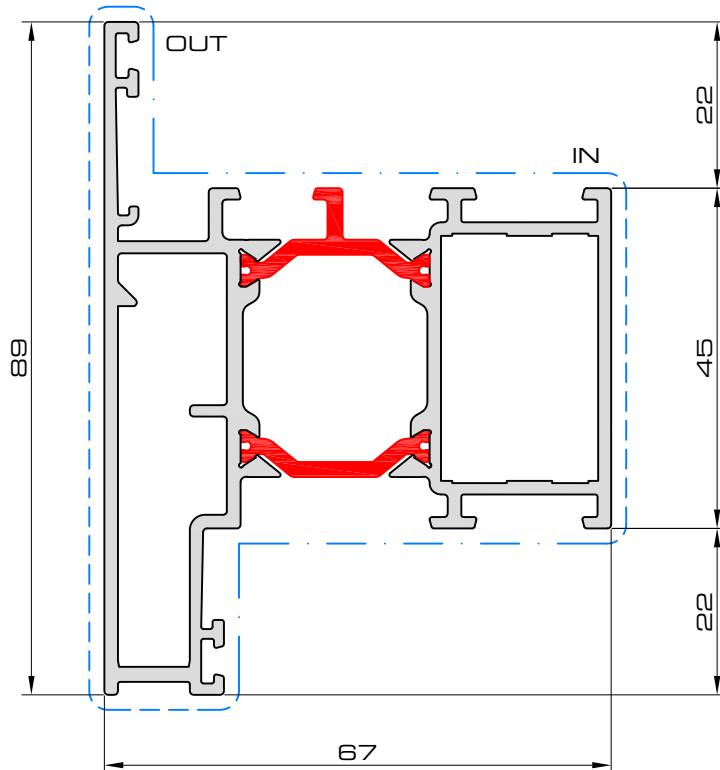

	OUT	IN
 P	A-PH-3709	A-PH-1621
 S	A-SH-3709	A-SH-1621
 V	-	A-VH-1621
	$I_x = 29.61\text{cm}^4$ $I_y = 14.7\text{cm}^4$ $W_x = 7.17\text{cm}^3$ $W_y = 3.75\text{cm}^3$	

P-02-319



	OUT	IN
 P	A-PH-4709	A-PH-3221
 S	A-SH-4709	A-SH-3221
 V	-	A-VH-3221
	$I_x = 37.25\text{cm}^4$ $I_y = 29.89\text{cm}^4$ $W_x = 9.2\text{cm}^3$ $W_y = 6.34\text{cm}^3$	

prof48

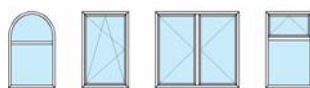

profielen ■ profils ■ profiles

P-02-310

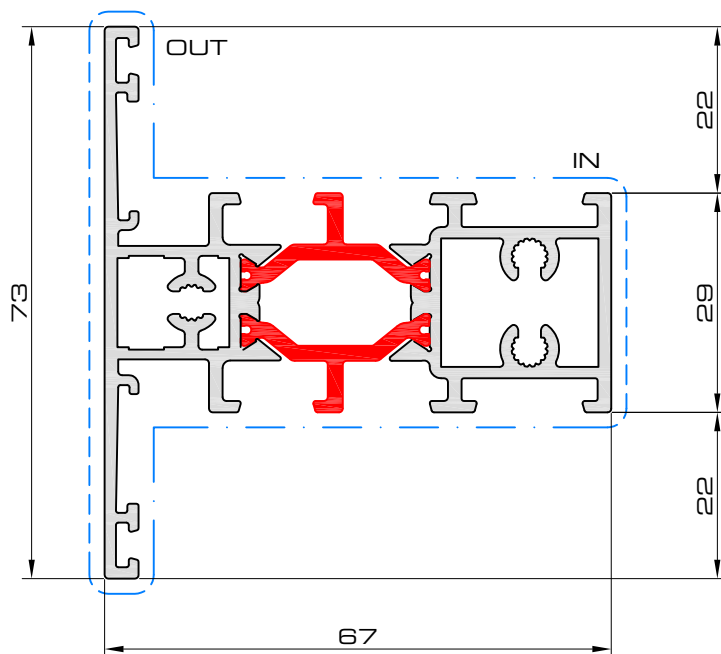

	$I_x = 31.56\text{cm}^4$
	$I_y = 10.34\text{cm}^4$
	$W_x = 8.27\text{cm}^3$
	$W_y = 2.83\text{cm}^3$

P-02-311

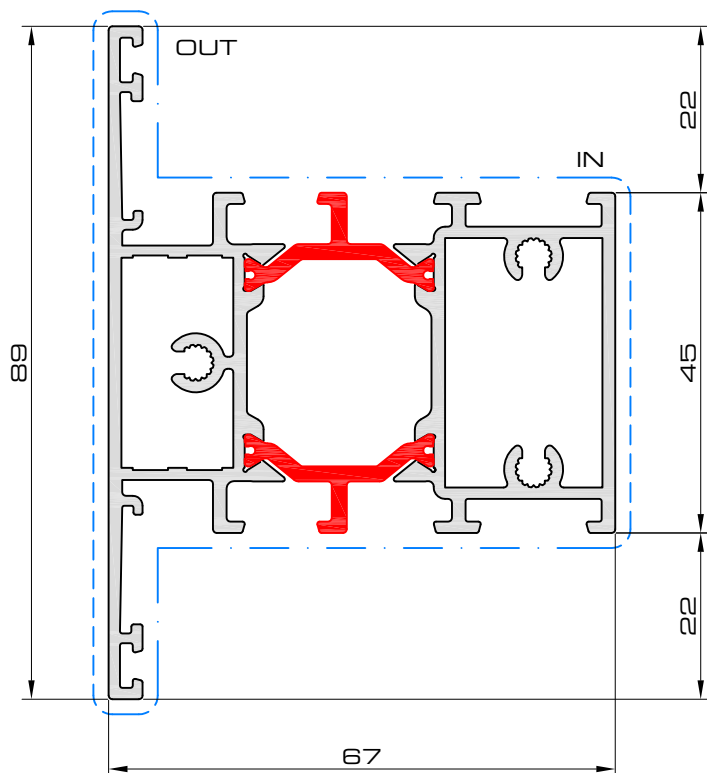

	$I_x = 38.55\text{cm}^4$
	$I_y = 23.26\text{cm}^4$
	$W_x = 10.25\text{cm}^3$
	$W_y = 5.23\text{cm}^3$

prof11



P-02-312

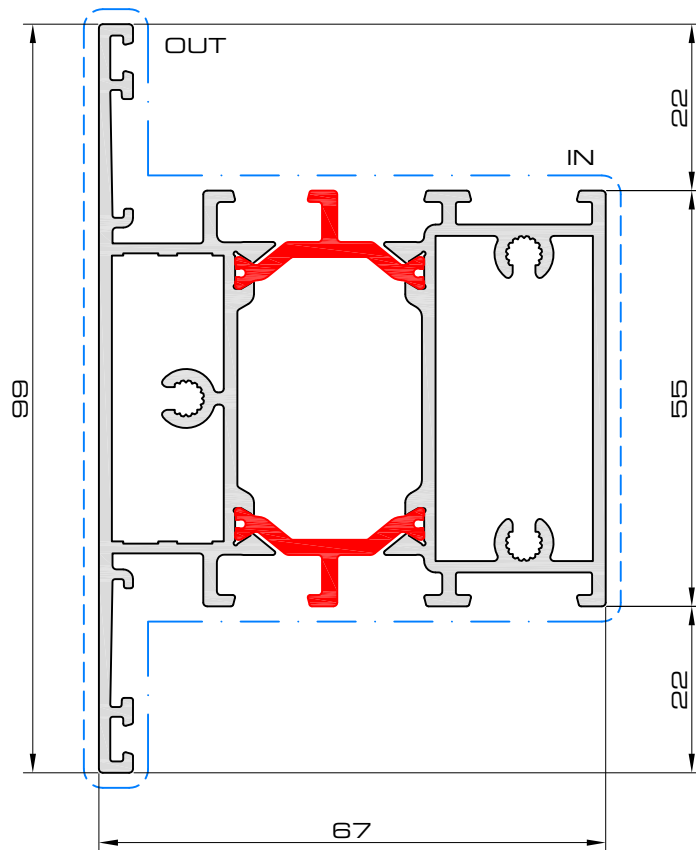

	$I_x = 42.85\text{cm}^4$
	$I_y = 35.42\text{cm}^4$
	$W_x = 11.47\text{cm}^3$
	$W_y = 7.16\text{cm}^3$

prof12

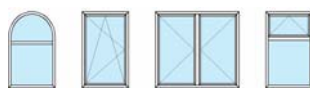

profielen ■ profils ■ profiles

Hercules P02

P-02-313

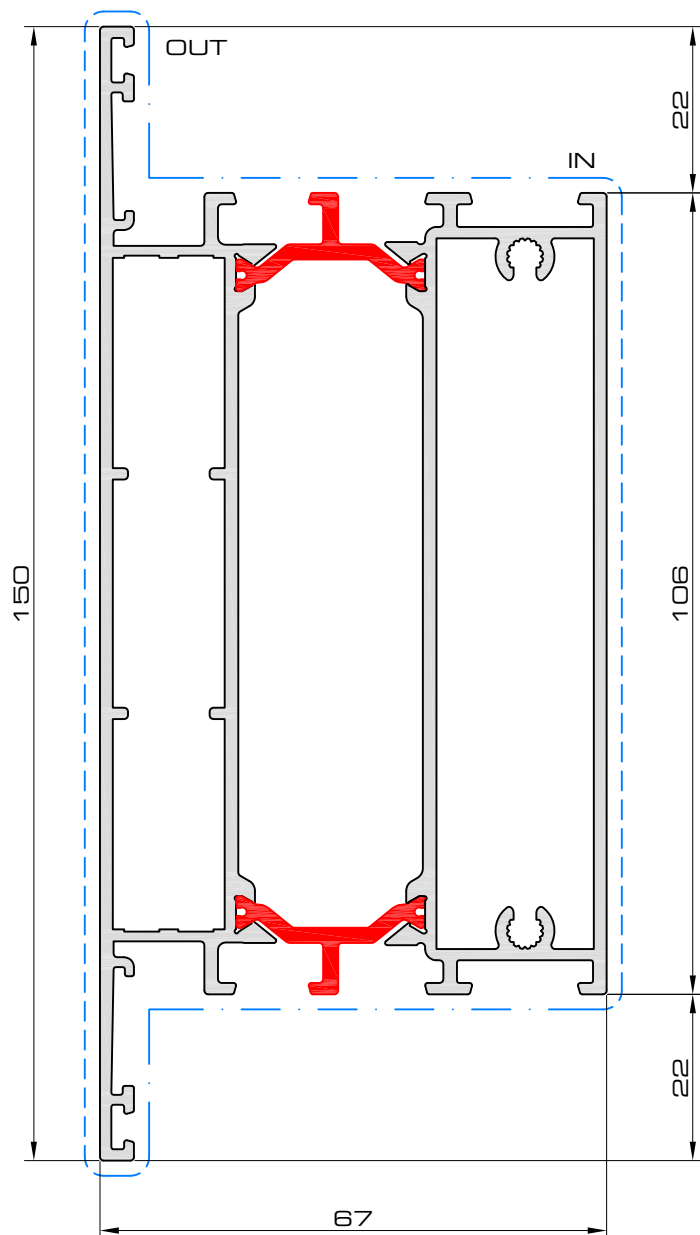

	$I_x = 65.67\text{cm}^4$
	$I_y = 160.52\text{cm}^4$
	$W_x = 17.73\text{cm}^3$
	$W_y = 21.4\text{cm}^3$

prof43

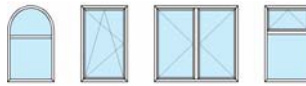

P-02-315

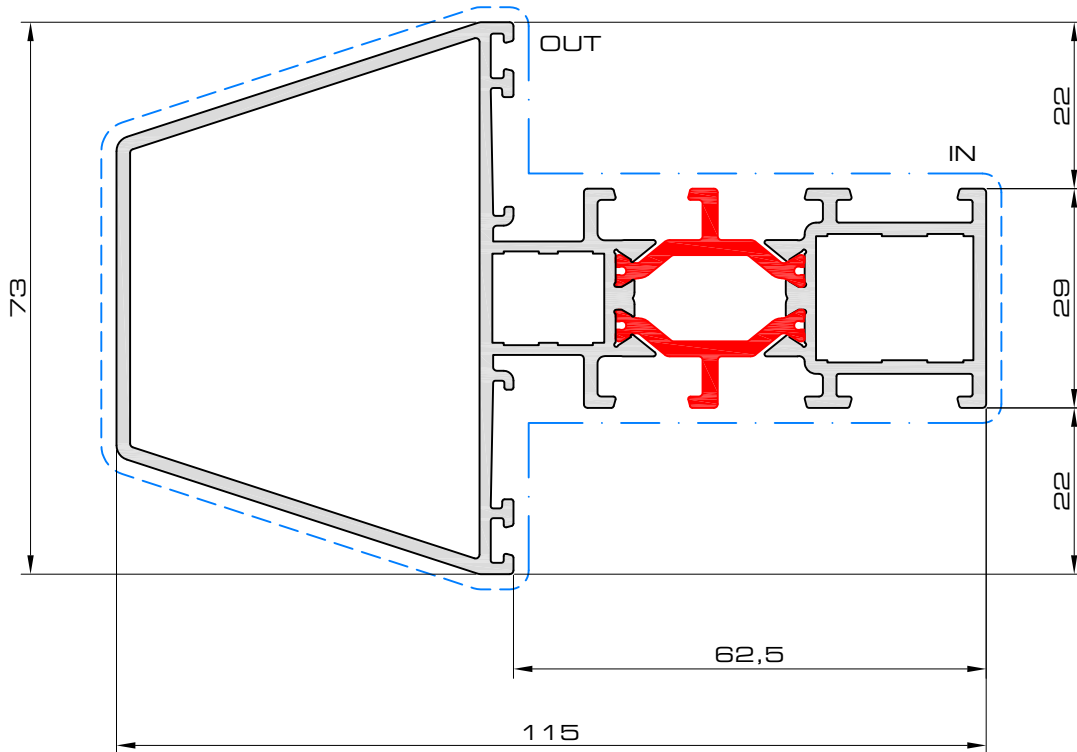

	OUT	IN
	-	-
	-	-
	A-TV-064	A-TV-001
	A-TV-057	A-TV-005
	-	-
	$I_x = 89.38 \text{cm}^4$ $I_y = 25.46 \text{cm}^4$ $W_x = 15.04 \text{cm}^3$ $W_y = 6.98 \text{cm}^3$	

prof13



profielen ■ profils ■ profiles



Hercules P02

P-02-320

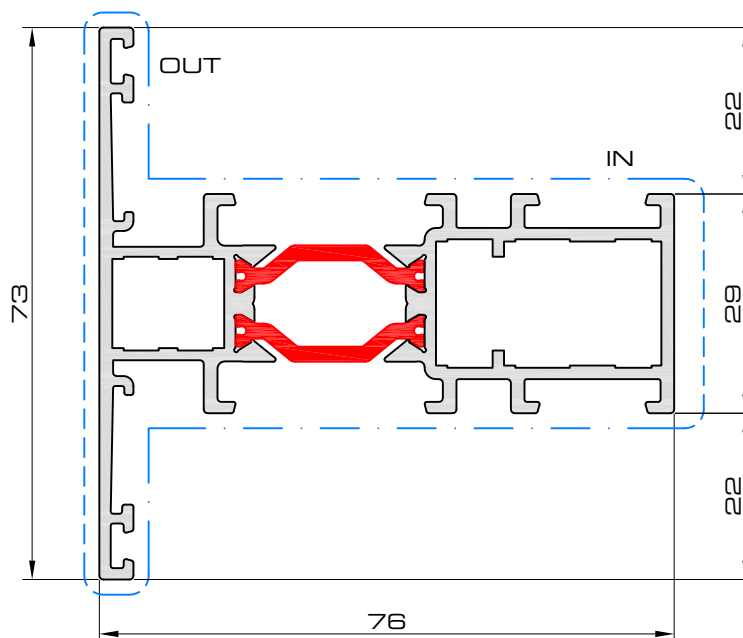

	OUT	IN
	-	-
	-	-
	A-TV-064	A-TV-001
	A-TV-057	A-TV-005
	A-VT-1115	A-VT-1621
	$I_x = 39.47\text{cm}^4$ $I_y = 10.74\text{cm}^4$ $W_x = 8.85\text{cm}^3$ $W_y = 2.94\text{cm}^3$	

prof25



P-02-400

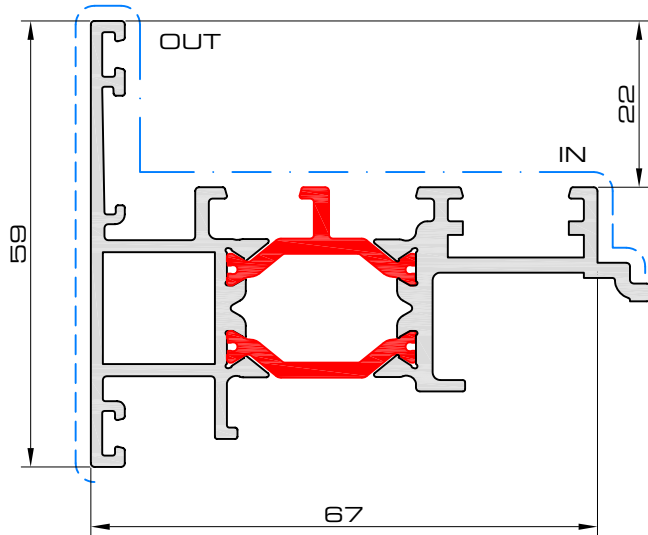

	$I_x = 25.03\text{cm}^4$
	$I_y = 6.75\text{cm}^4$
	$W_x = 5.36\text{cm}^3$
	$W_y = 2\text{cm}^3$

P-02-404

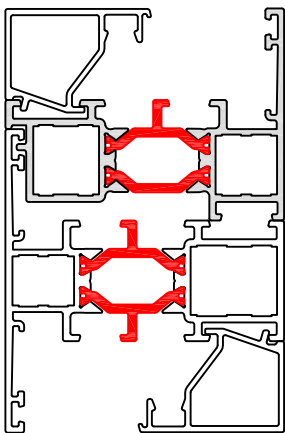

	$I_x = 21.82\text{cm}^4$
	$I_y = 5.43\text{cm}^4$
	$W_x = 5.57\text{cm}^3$
	$W_y = 1.68\text{cm}^3$

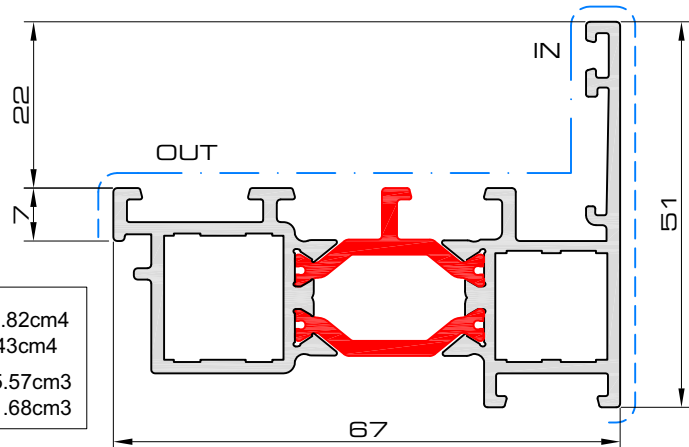

P-02-405

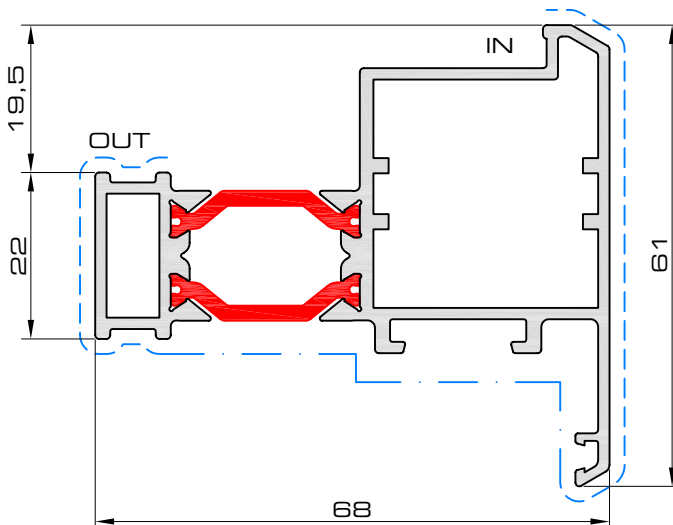

	OUT	IN
	A-PH-1607	A-PH-3025
	A-PH-1607	A-SH-3025
	-	-
	-	-
	$I_x = 23.84\text{cm}^4$	
	$I_y = 8.58\text{cm}^4$	
	$W_x = 6.06\text{cm}^3$	
	$W_y = 2.59\text{cm}^3$	

prof14

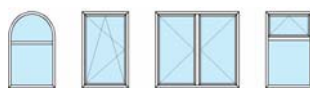

profielen ■ profils ■ profiles

P-02-424

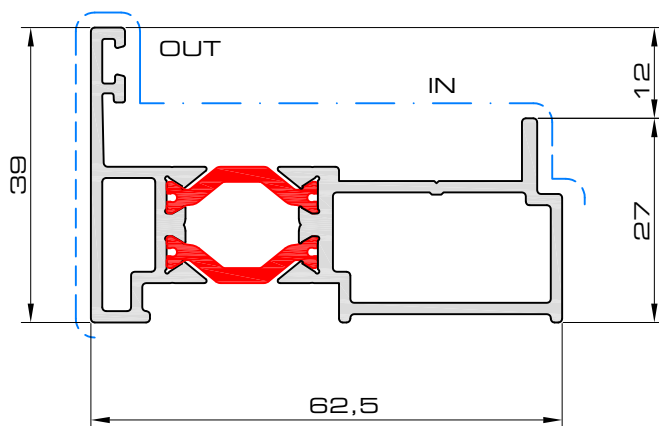

P-02-425

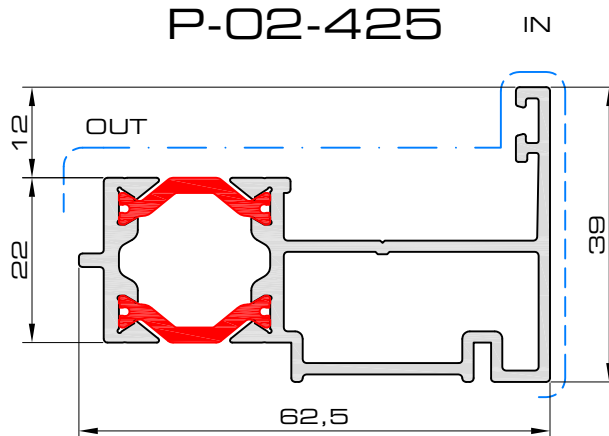

P-02-426

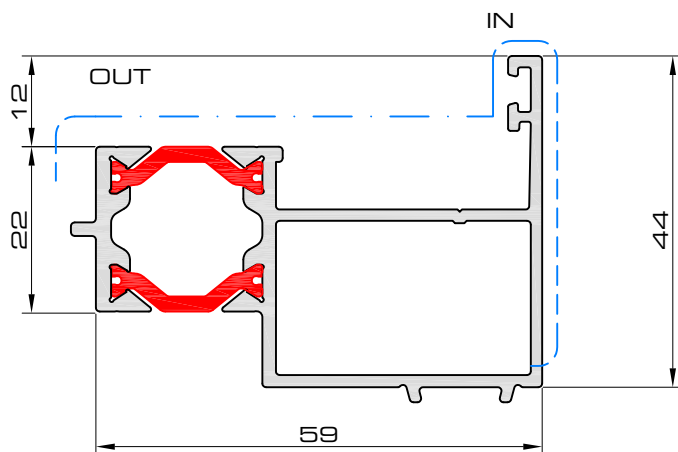

P-02-535

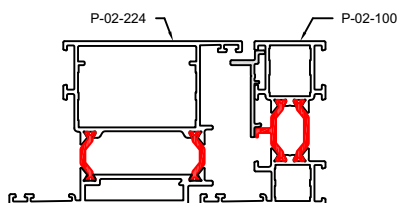
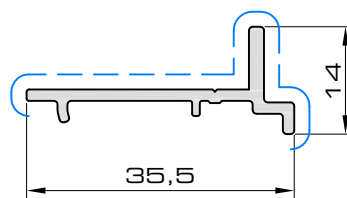

prof31



P-02-500

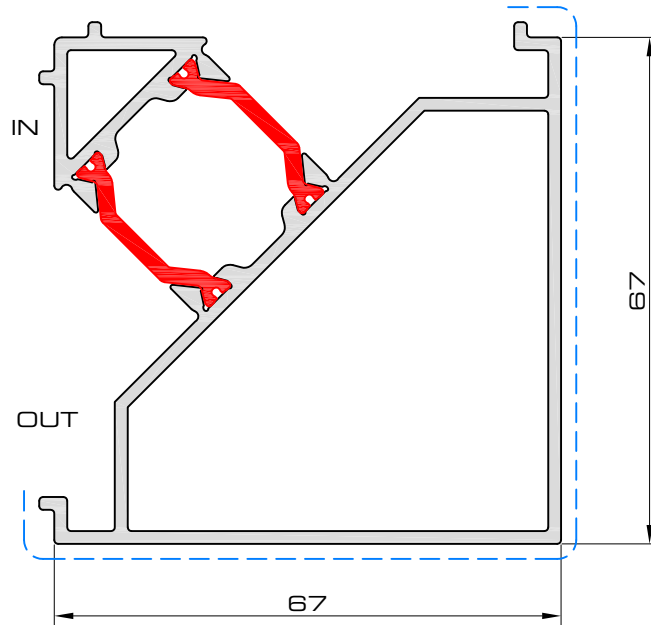

P-02-510

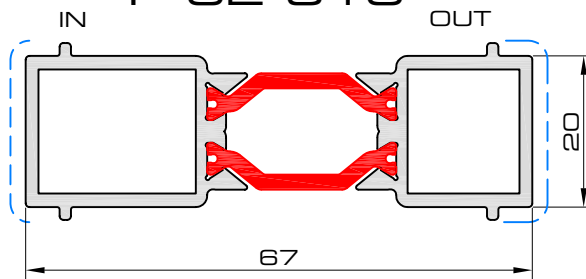

	$I_x = 16.73\text{cm}^4$
	$I_y = 1.76\text{cm}^4$
	$W_x = 4.98\text{cm}^3$
	$W_y = 1.51\text{cm}^3$

P-02-530

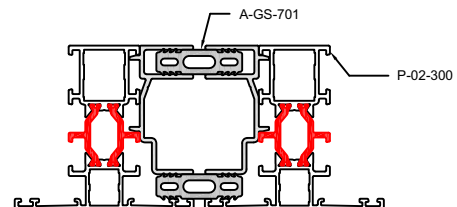
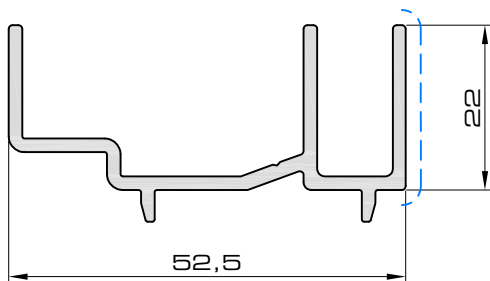

prof16



Hercules P02

profielen ■ profils ■ profiles

P-02-514

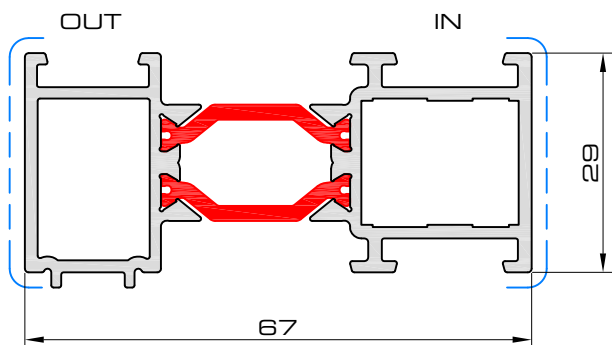

	$I_x = 20.5\text{cm}^4$
	$I_y = 3.27\text{cm}^4$
	$W_x = 6.08\text{cm}^3$
	$W_y = 2.03\text{cm}^3$

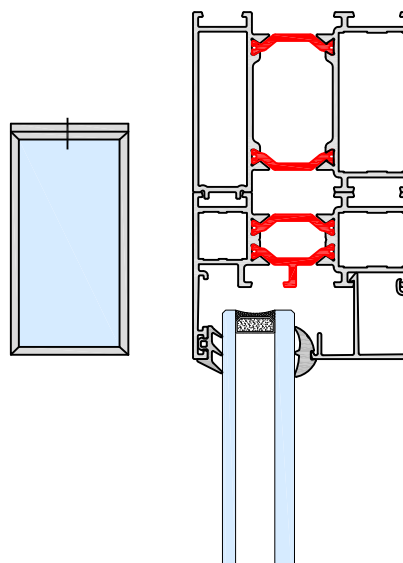

P-02-515

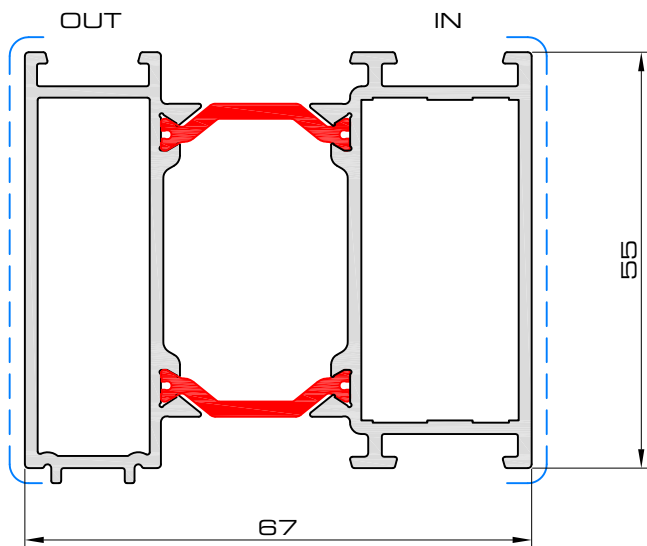

	$I_x = 31.7\text{cm}^4$
	$I_y = 19.24\text{cm}^4$
	$W_x = 9.36\text{cm}^3$
	$W_y = 6.6\text{cm}^3$

prof36

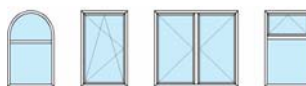

P-02-516

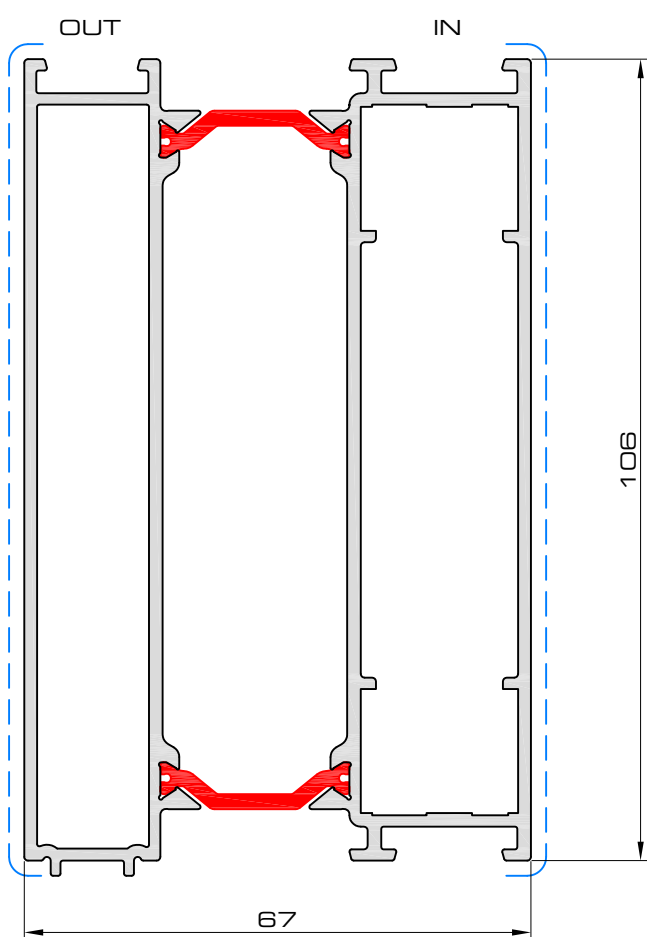

	$I_x = 54.15\text{cm}^4$
	$I_y = 113.76\text{cm}^4$
	$W_x = 15.9\text{cm}^3$
	$W_y = 20.81\text{cm}^3$

prof44

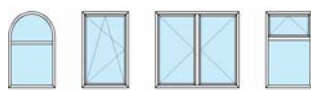

profielen ■ profils ■ profiles

Hercules P02

P-02-700

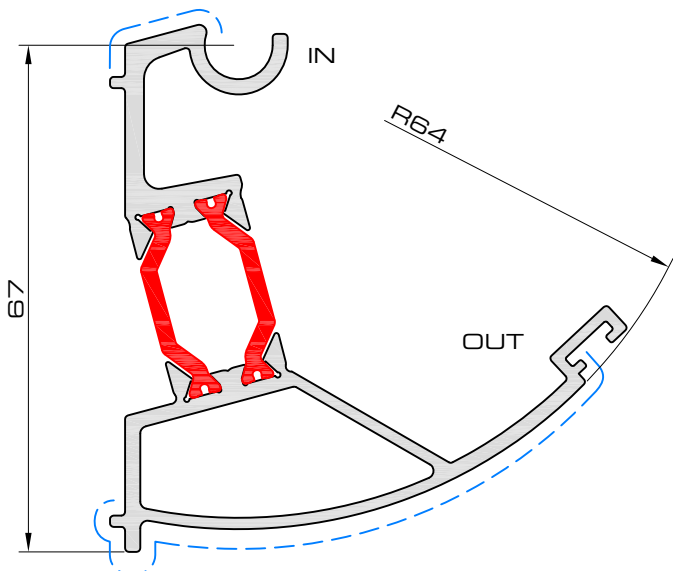

P-02-702

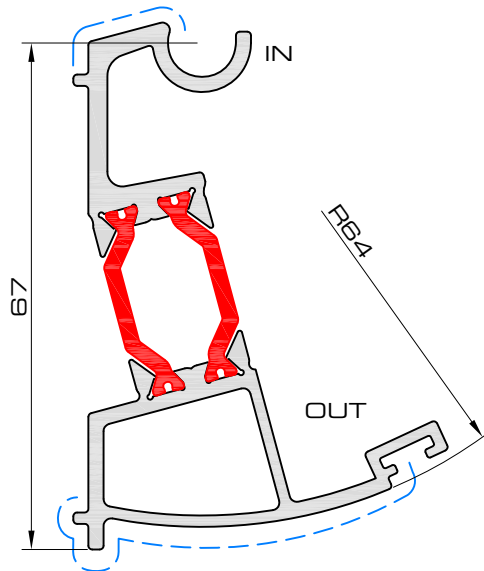

P-02-701

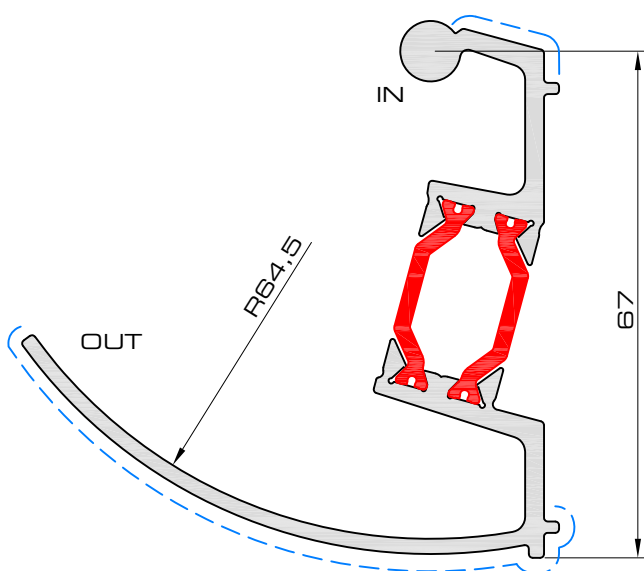

P-02-703

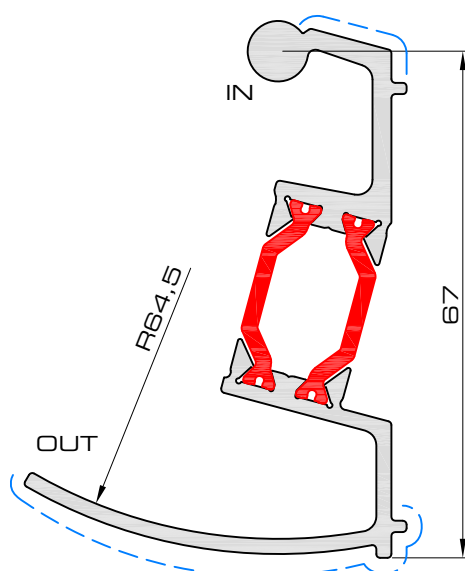

prof15

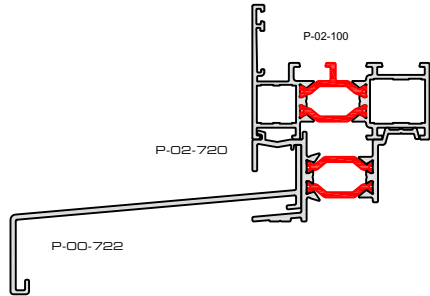
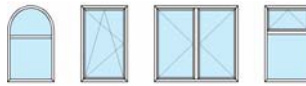

P-02-720

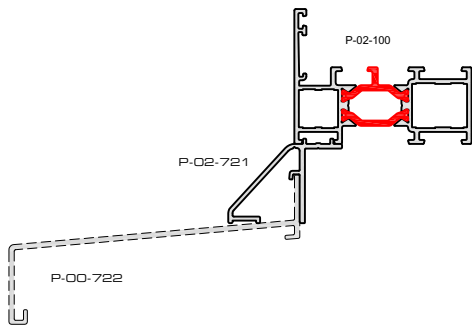
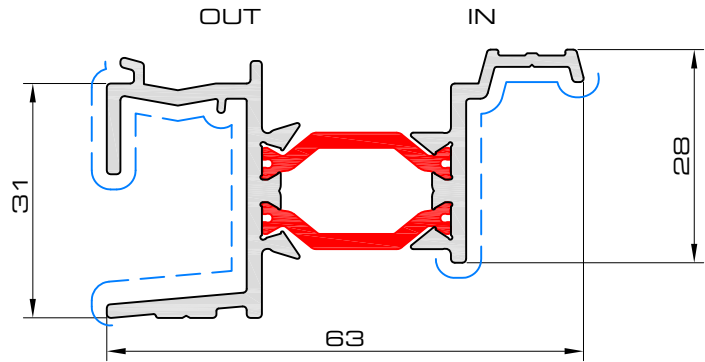

P-02-721

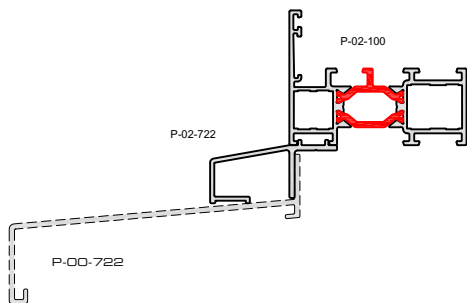
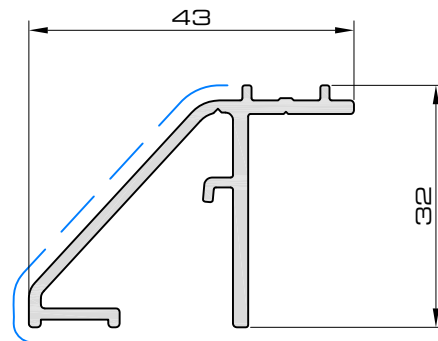

P-02-722

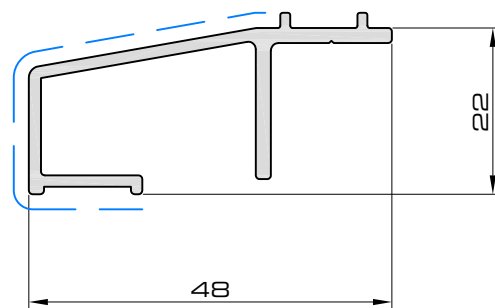

prof32

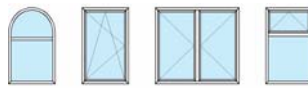

profielen ■ profils ■ profiles

Hercules P02

P-02-723

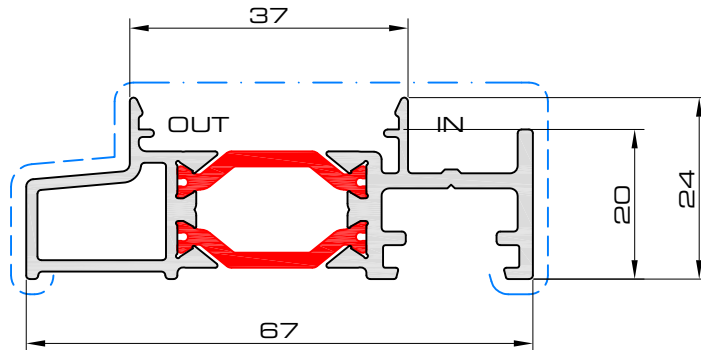

P-02-724

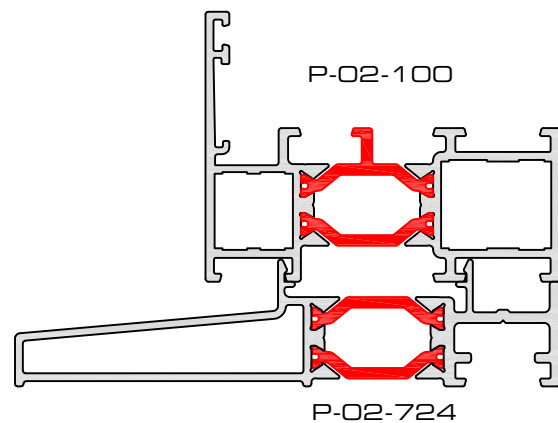
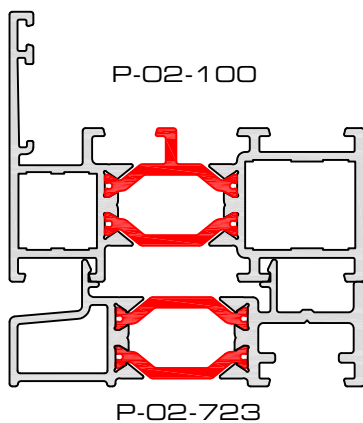
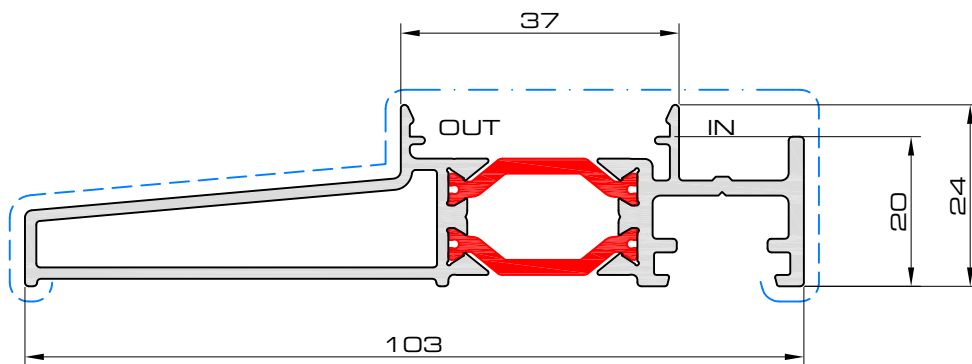

prof49



P-02-725

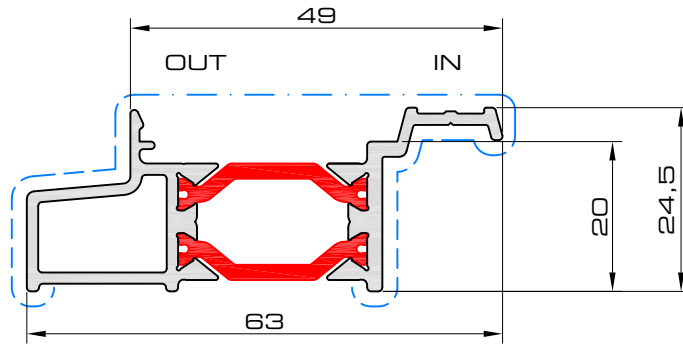

P-02-726

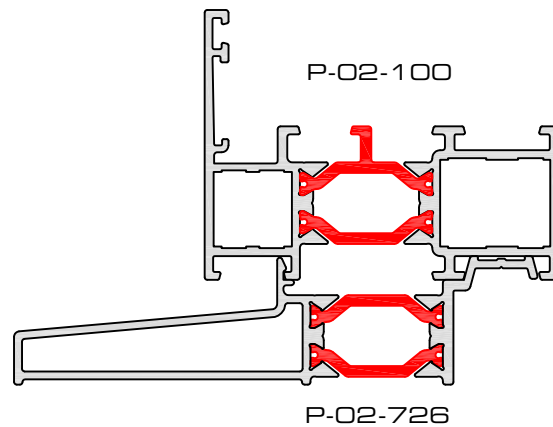
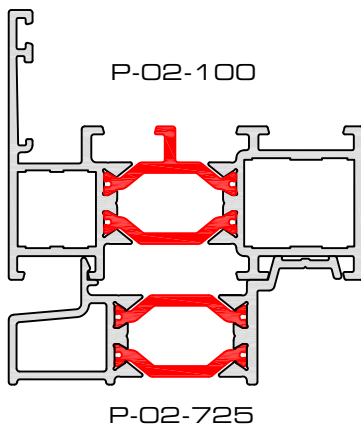
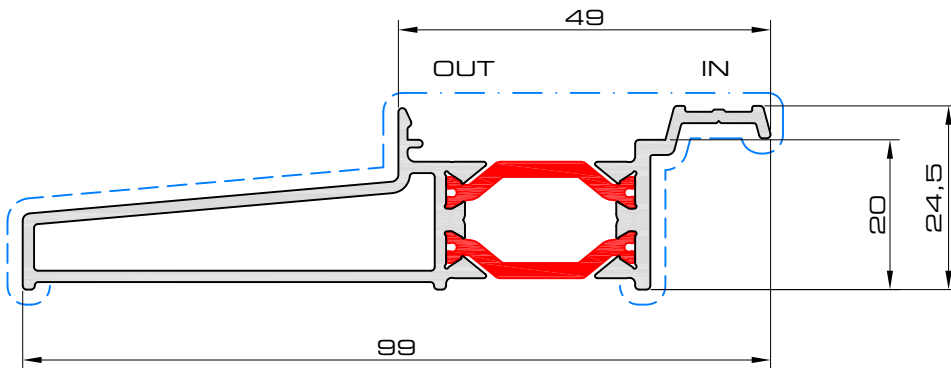

prof50

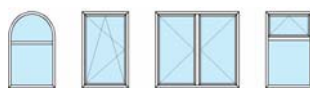

P-02-727

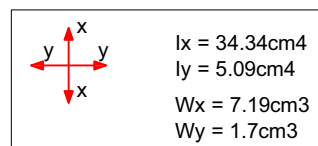
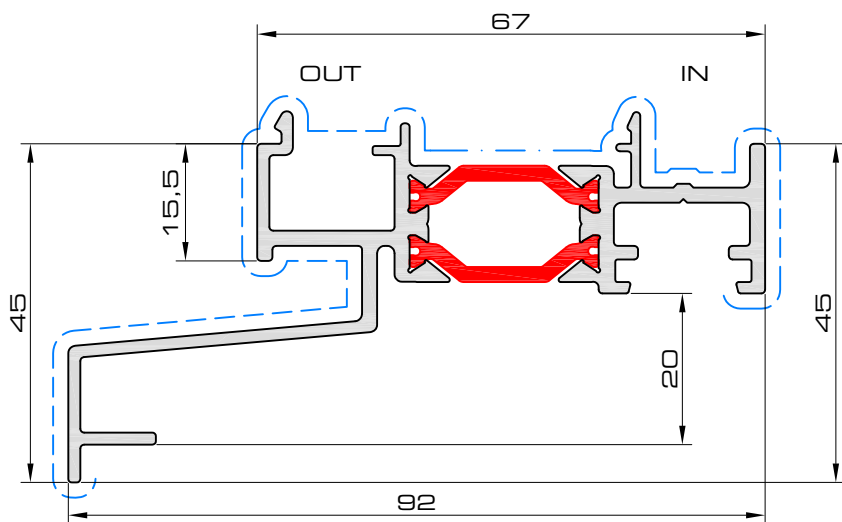

P-02-728

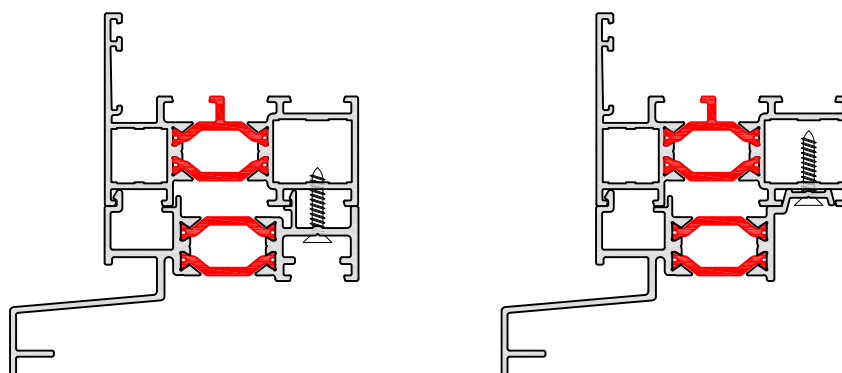
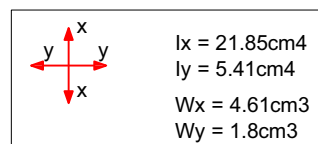
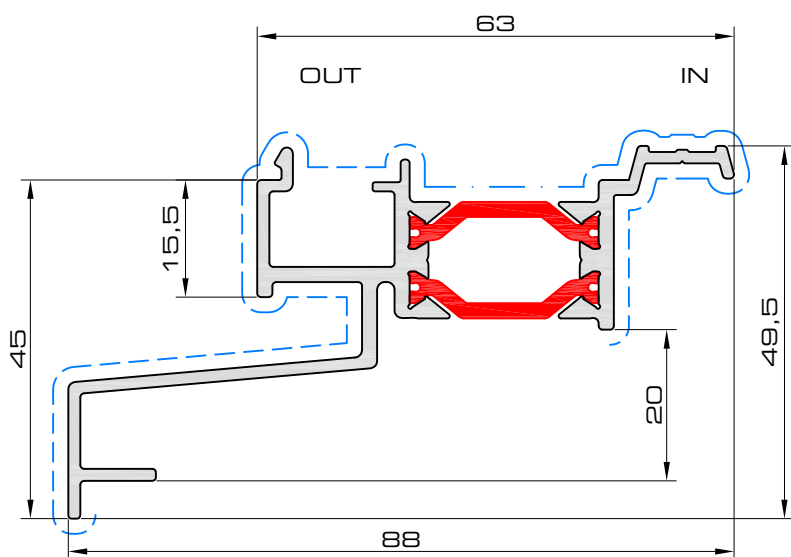

prof55

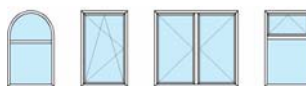

P-02-735

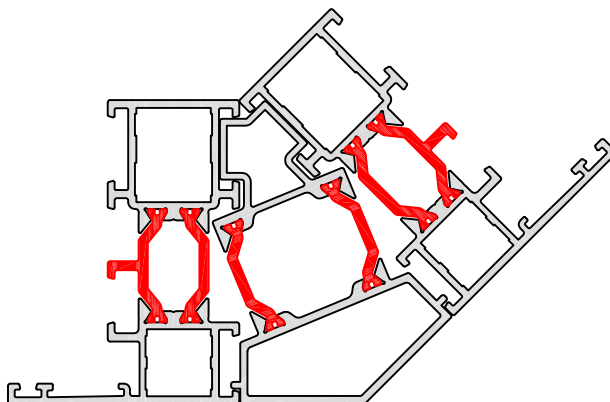
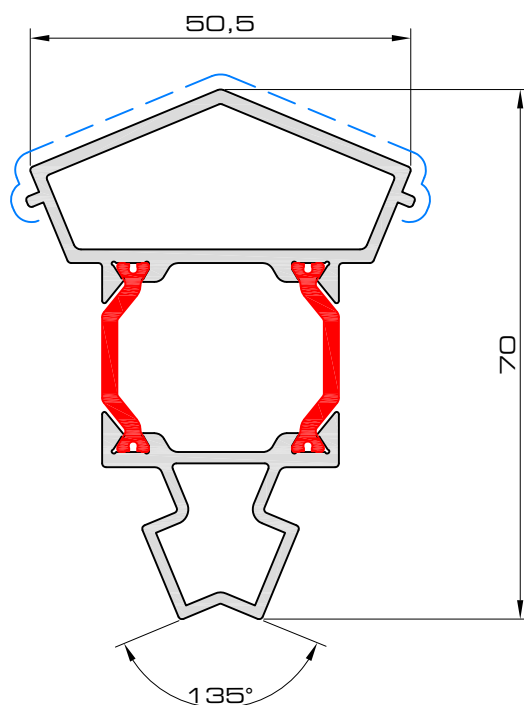

prof35



Hercules P02

profielen ■ profils ■ profiles

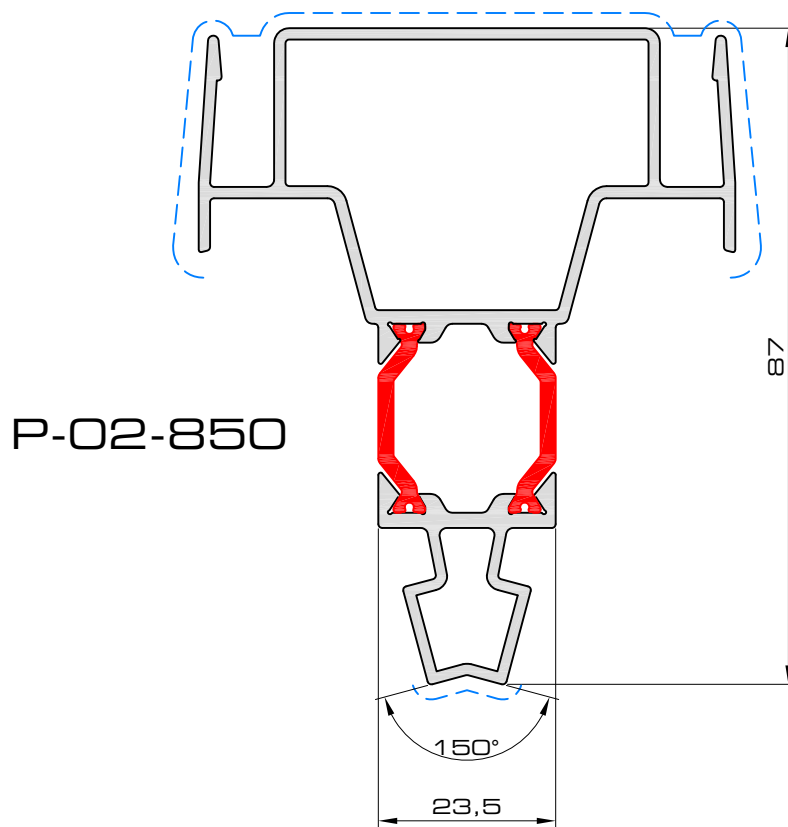
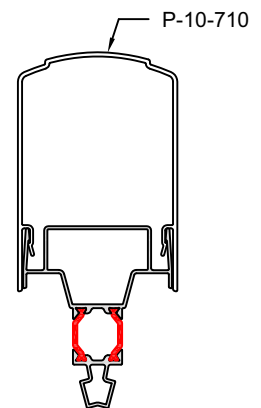
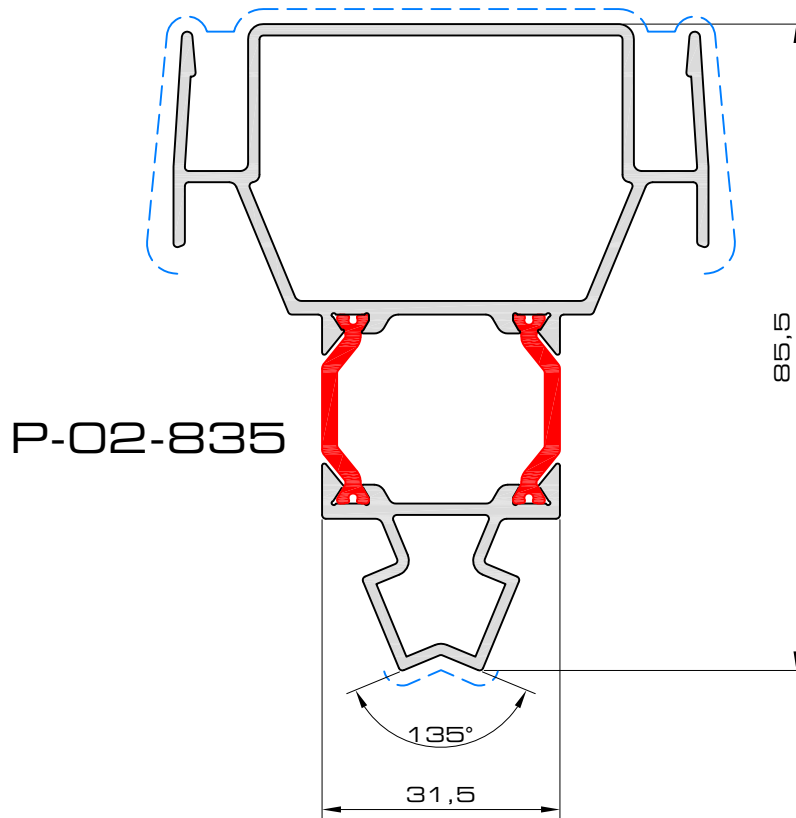

prof18

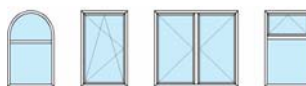

P-00-500

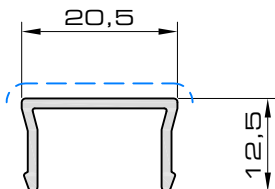

P-02-900

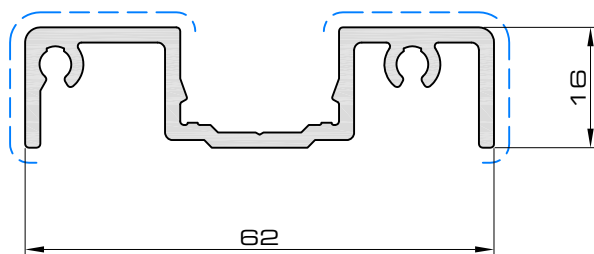

P-02-901

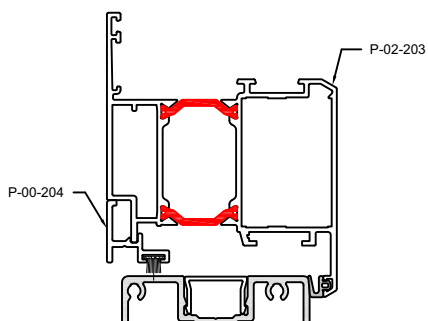
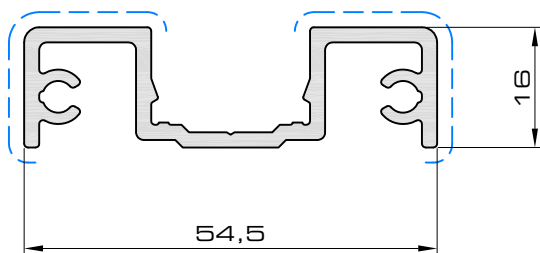

prof33

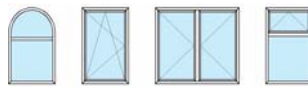

Hercules P02

profielen ■ profils ■ profiles

P-00-100

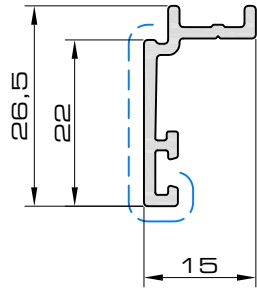

P-00-101

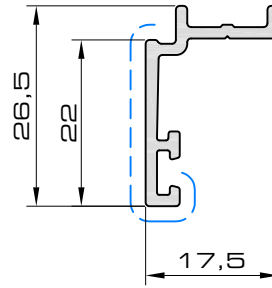

P-00-105

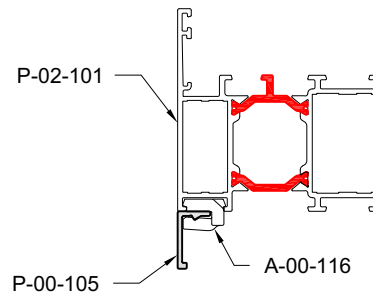
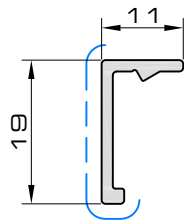

P-00-106

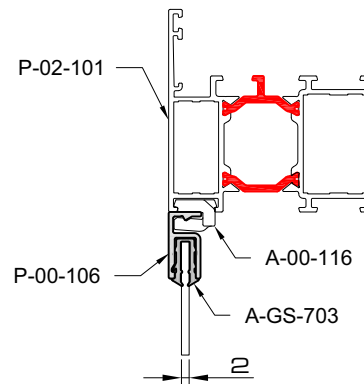
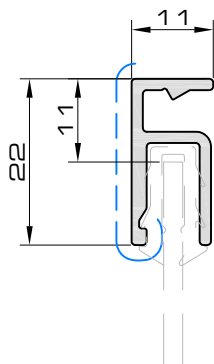

prof19



P-00-203

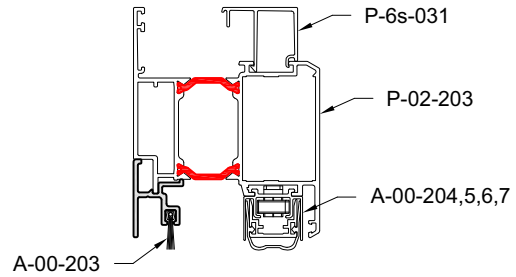
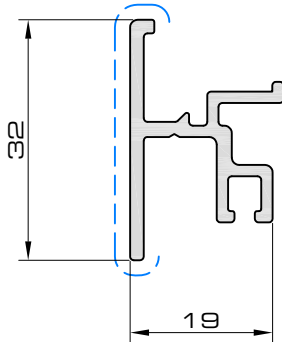

P-00-204

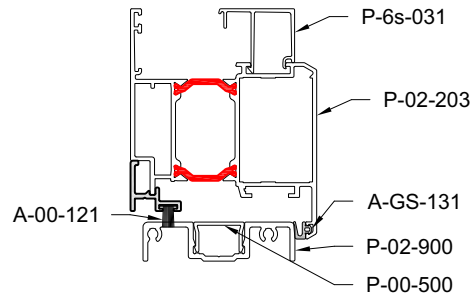
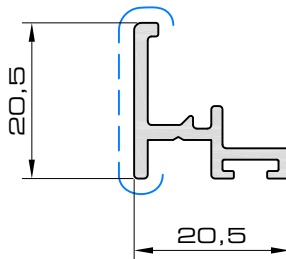

P-00-207

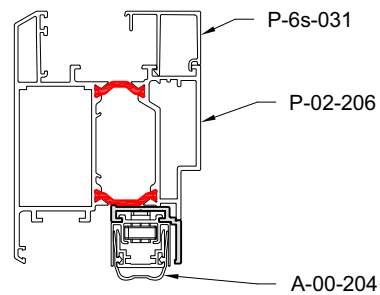
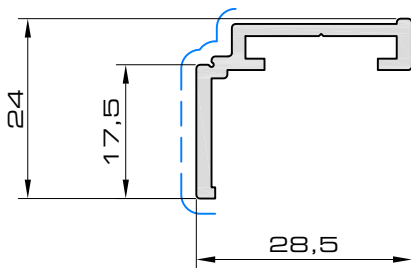

P-00-208

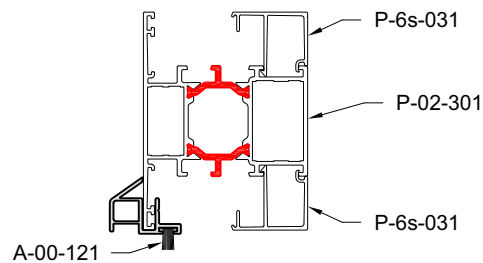
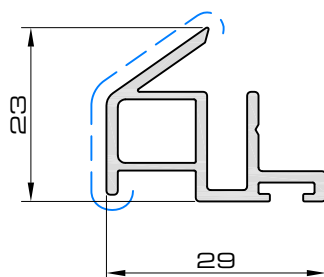

prof37

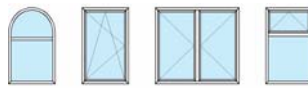

Hercules P02

profielen ■ profils ■ profiles

P-00-205

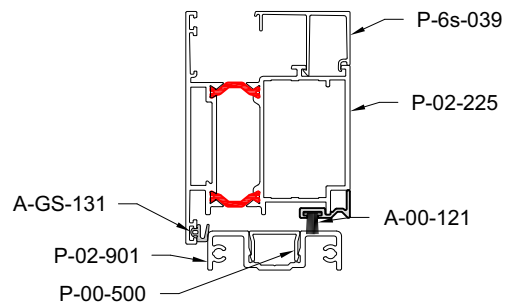
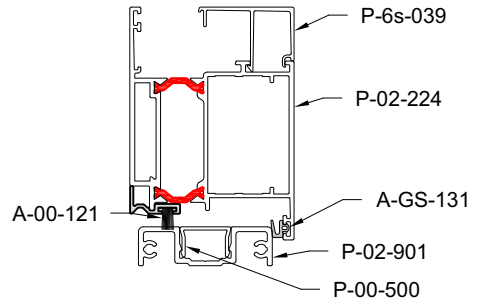
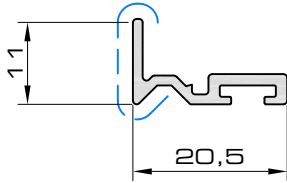

P-00-206

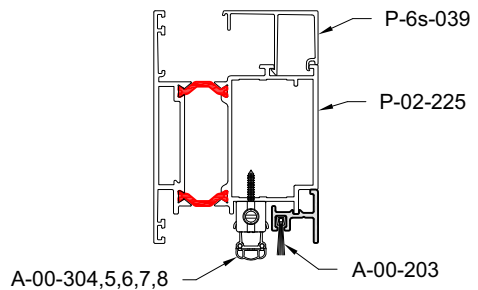
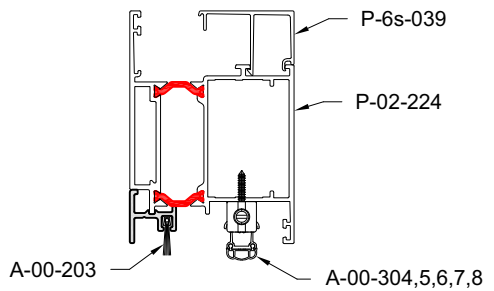
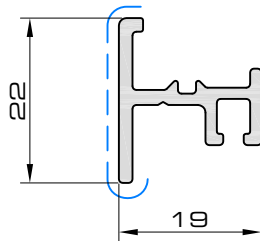

prof39



P-00-601

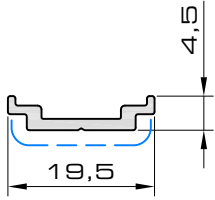

P-00-602

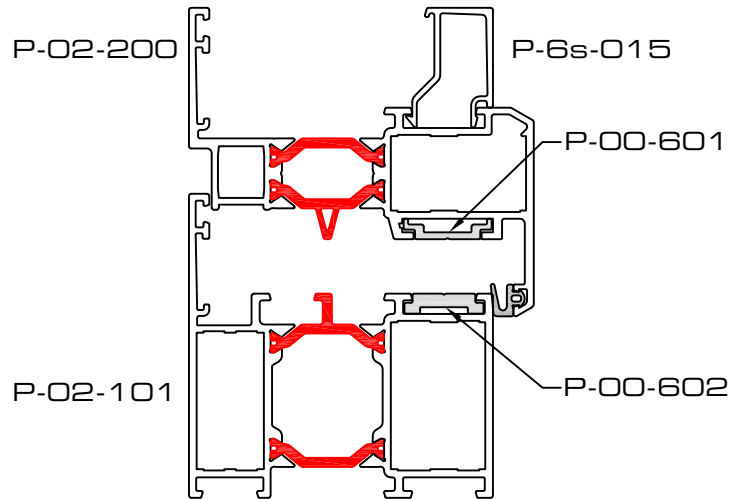
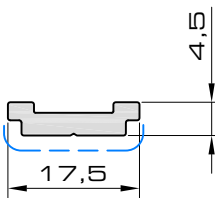

P-00-610

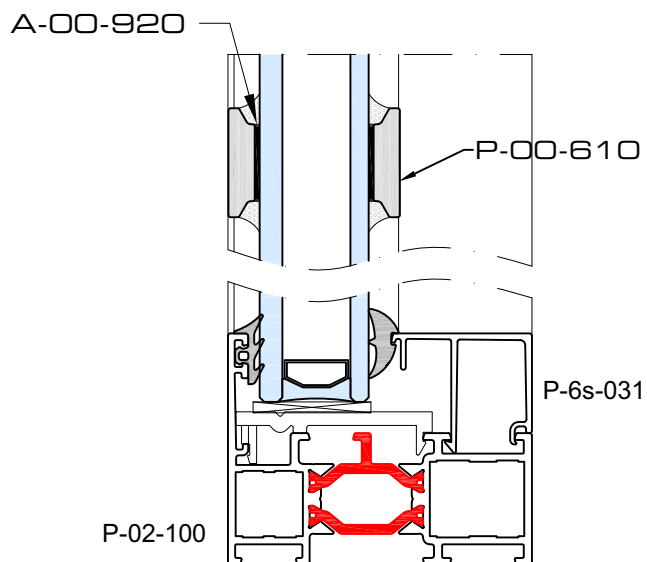
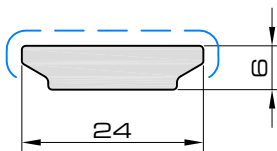

prof40



profielen ■ profils ■ profiles

P-00-511

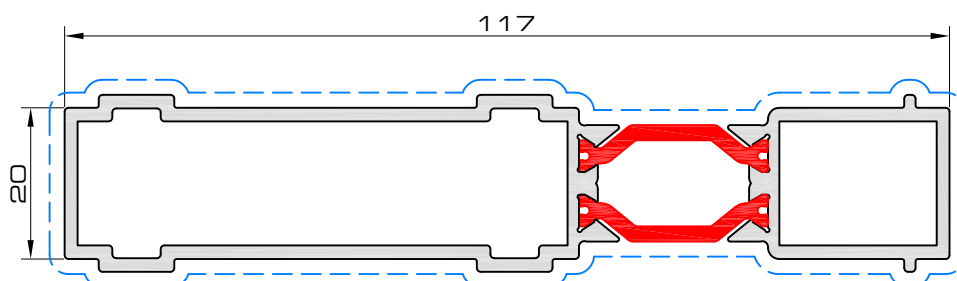

	$I_x = 72.51\text{cm}^4$
	$I_y = 3.65\text{cm}^4$
	$W_x = 12.39\text{cm}^3$
	$W_y = 3.12\text{cm}^3$

P-00-512

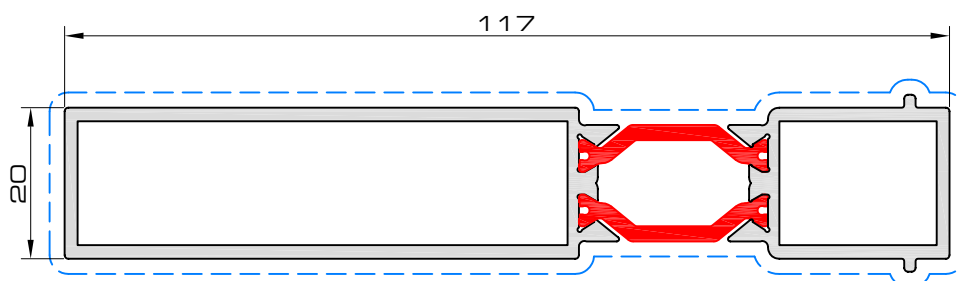

	$I_x = 69.49\text{cm}^4$
	$I_y = 3.21\text{cm}^4$
	$W_x = 11.65\text{cm}^3$
	$W_y = 2.74\text{cm}^3$

P-00-515

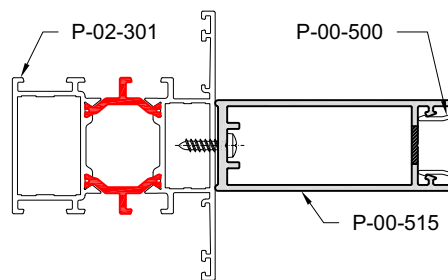
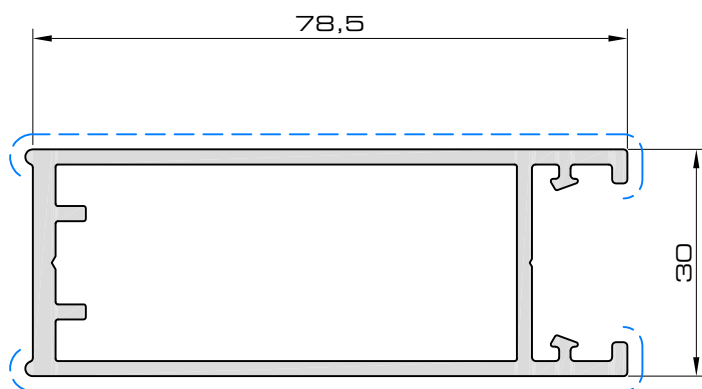

	$I_x = 35.37\text{cm}^4$
	$I_y = 7.34\text{cm}^4$
	$W_x = 8.35\text{cm}^3$
	$W_y = 4.89\text{cm}^3$

prof38

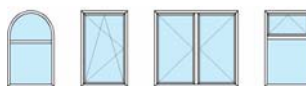

P-00-700

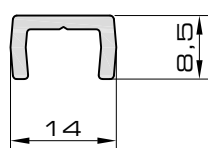

P-00-702

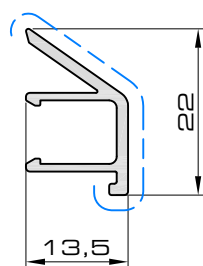

P-00-710

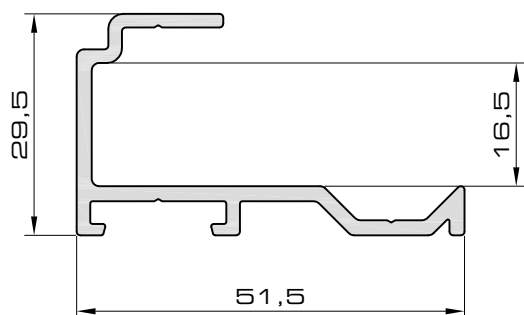

P-00-711

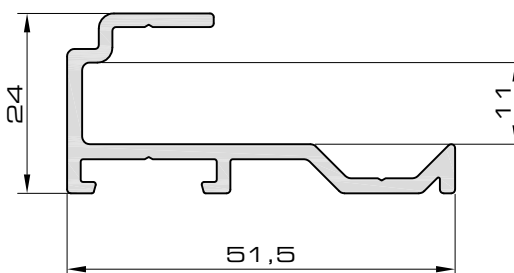

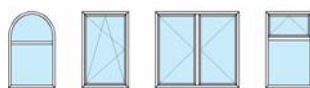

profielen ■ profils ■ profiles

Hercules P02

P-00-703

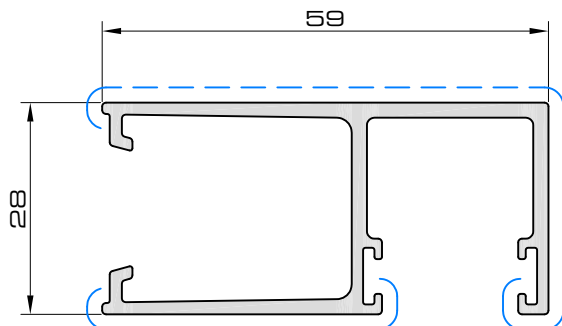

P-00-704

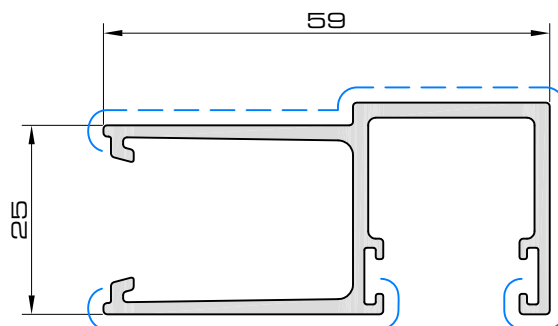

P-00-706

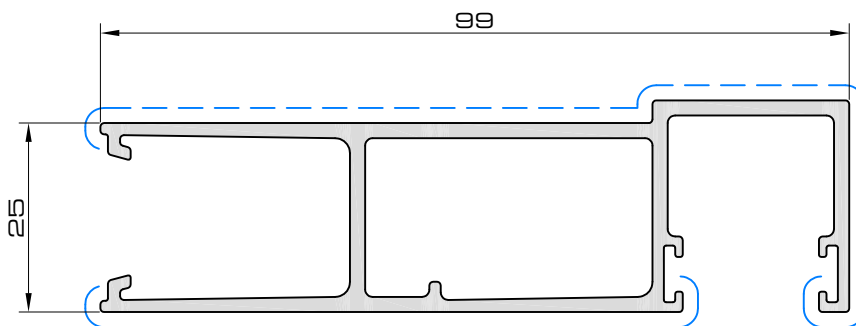

P-00-705

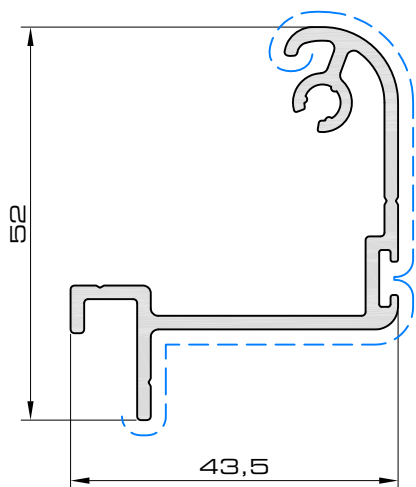

P-00-707

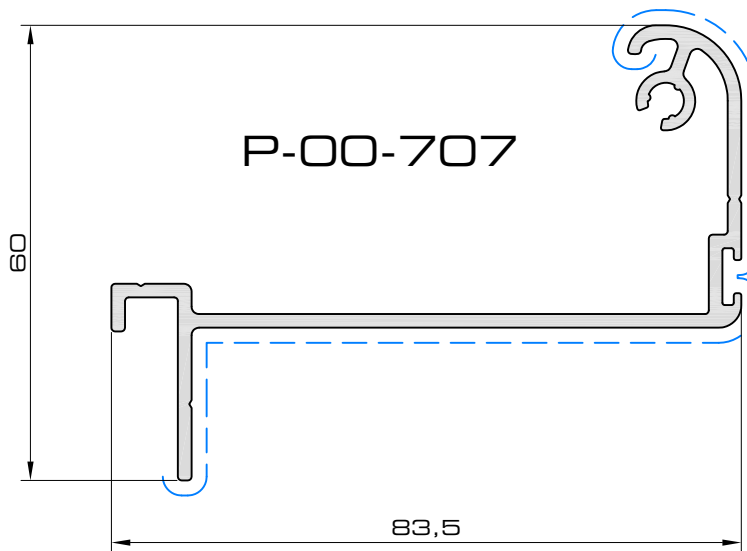

prof20



P-00-720

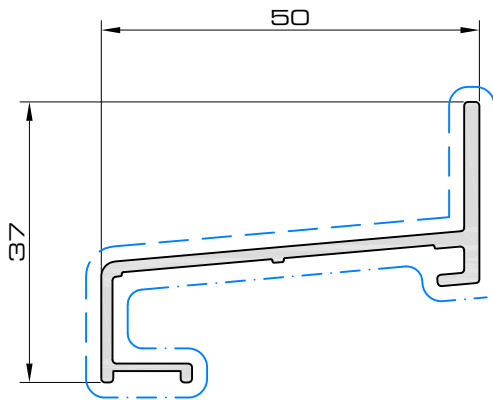

P-00-721

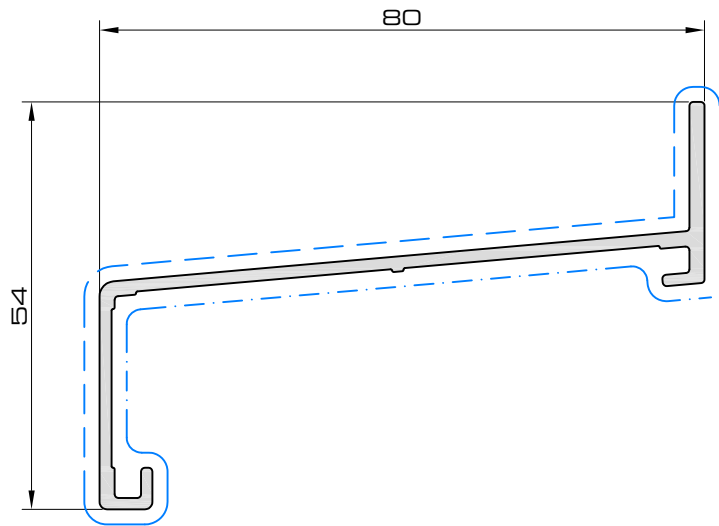

P-00-722

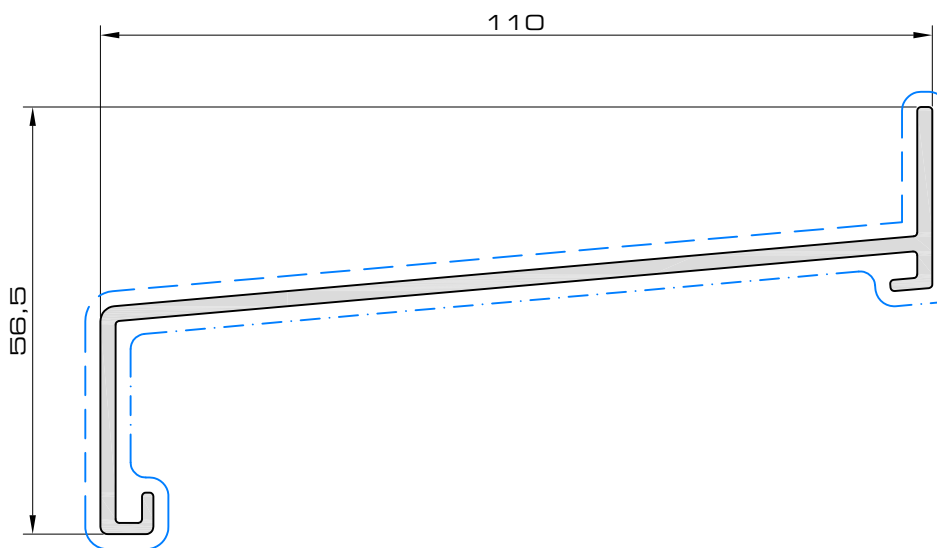

prof8



profielen ■ profils ■ profiles

Hercules P02

P-00-723

140

59

P-00-724

170

62

prof9

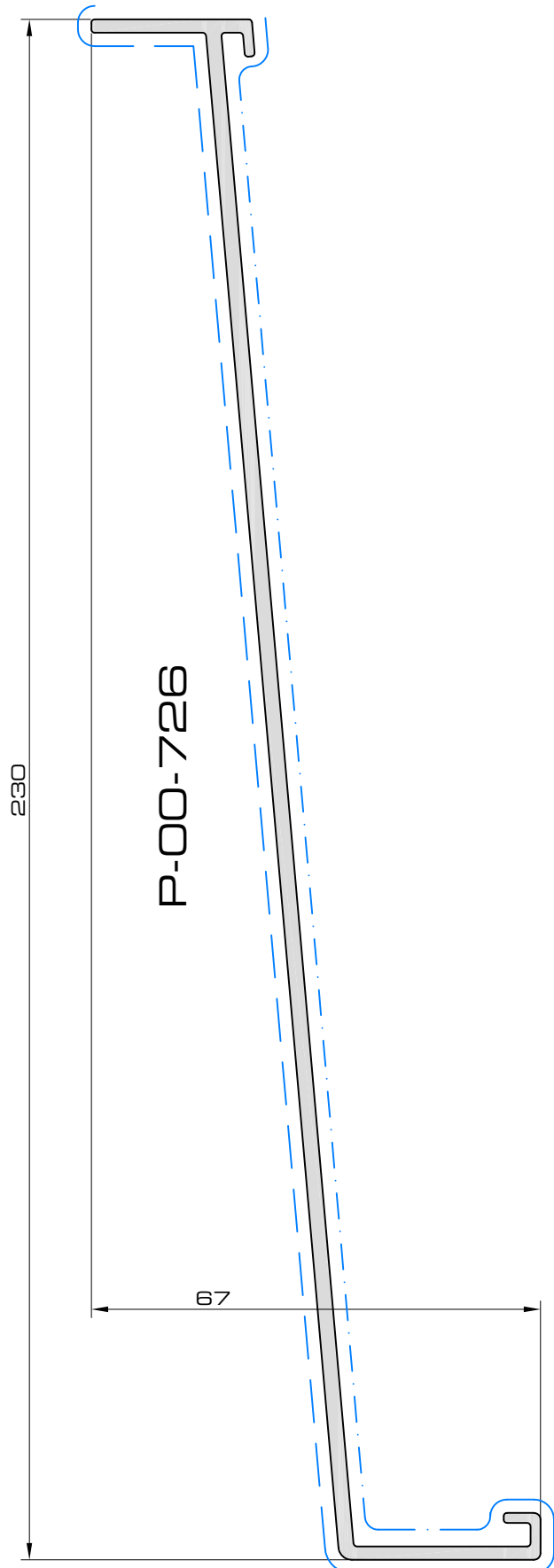
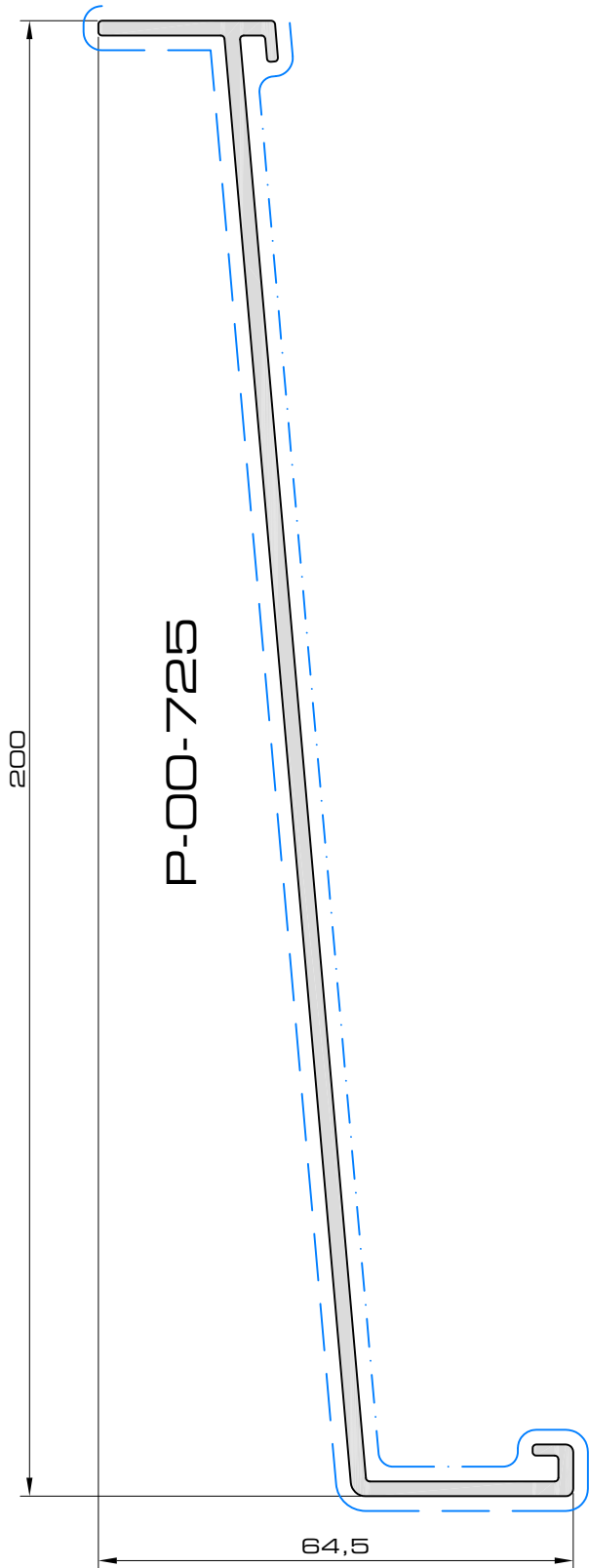
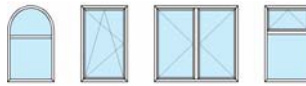

prof10



P-6s-003

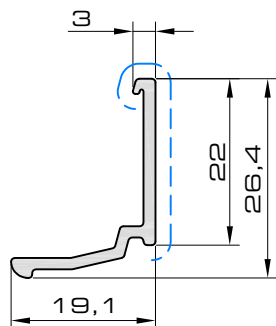

P-6s-007

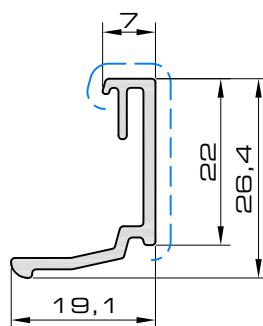

P-6s-011

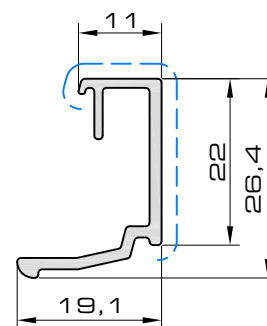

P-6s-013

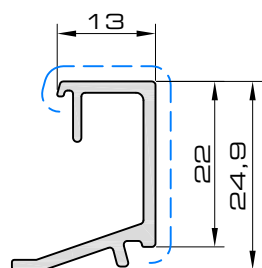

P-6s-015

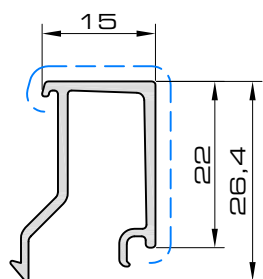

P-6s-019

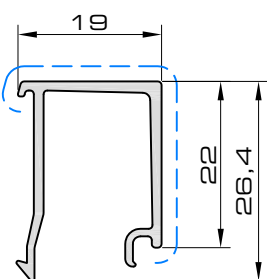

P-6s-021

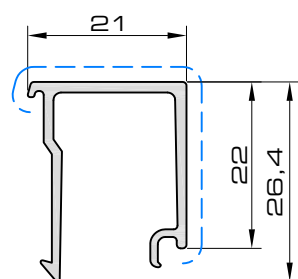

P-6s-023

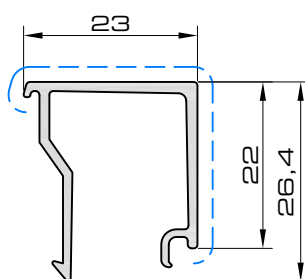

P-6s-025

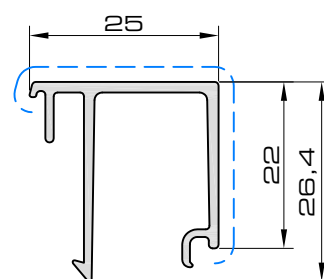

P-6s-027

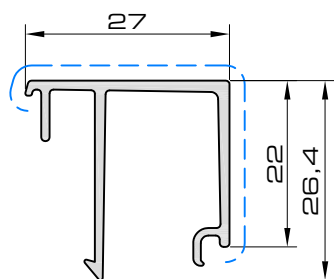

P-6s-029

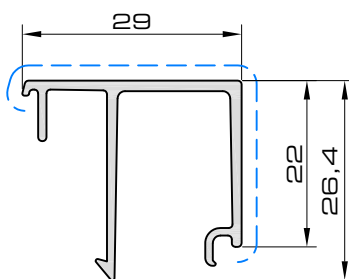

P-6s-031

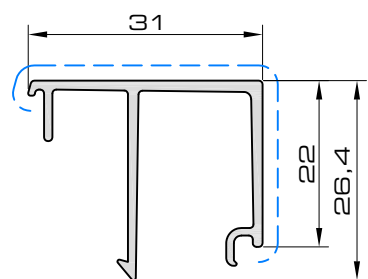

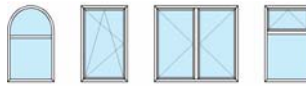

P-6s-033

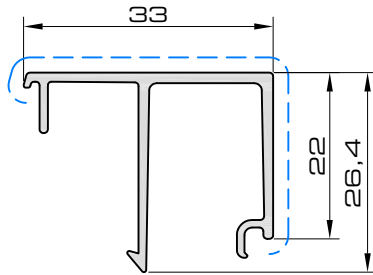

P-6s-035

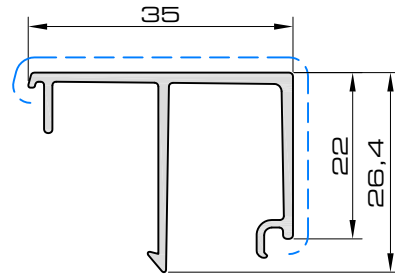

P-6s-037

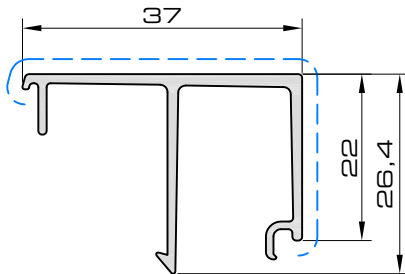

P-6s-039

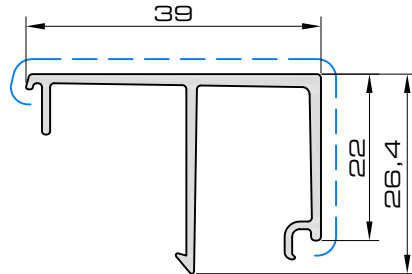

P-6s-041

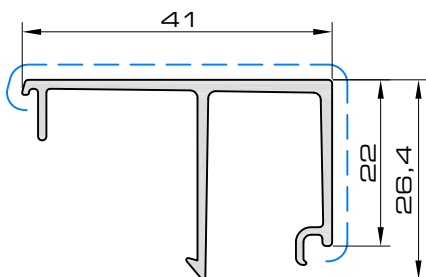

P-6s-043

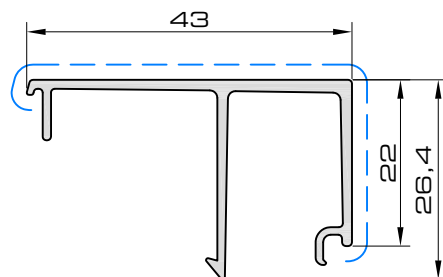

P-6s-045

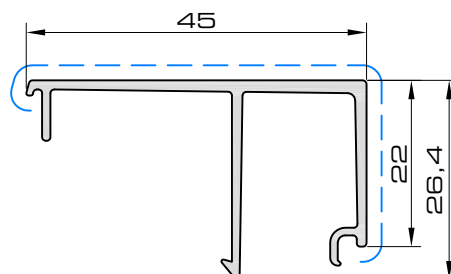

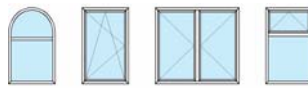

profielen ■ profils ■ profiles

Hercules P02

P-6s-J29

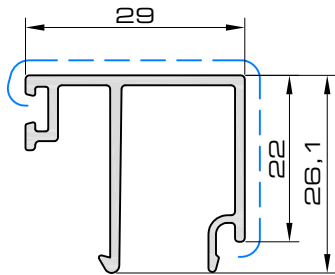

P-6s-J33

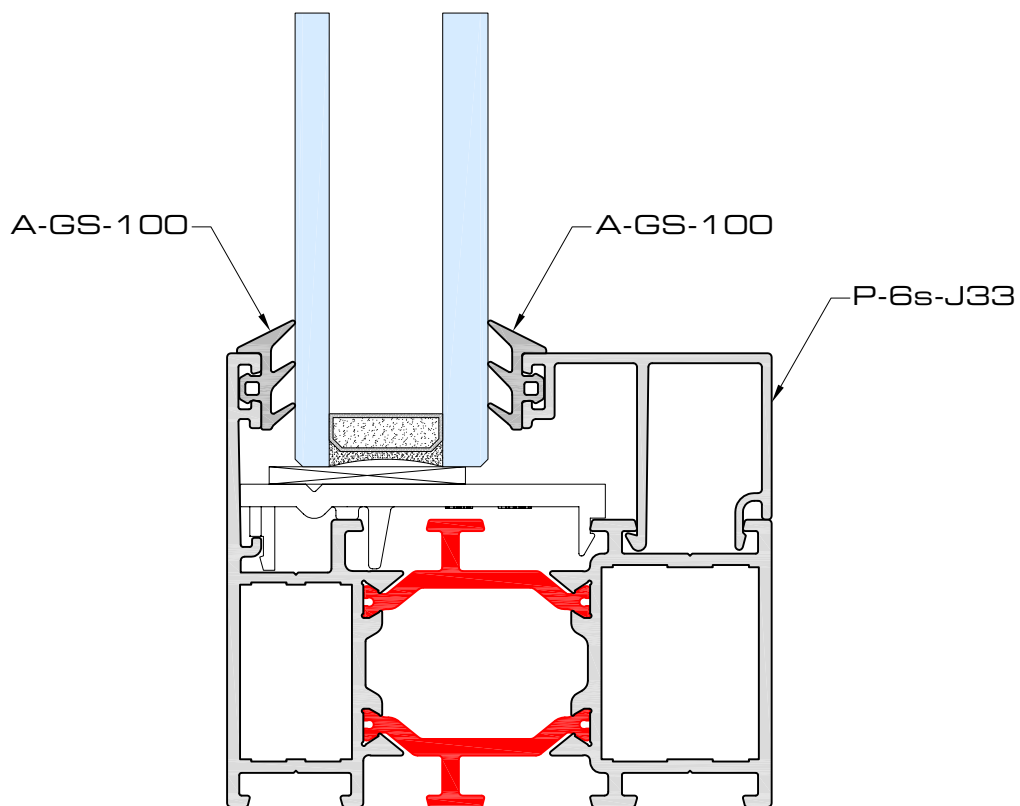
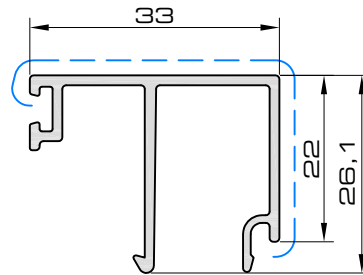



P-6b-015

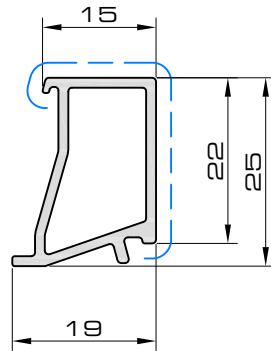

P-6b-019

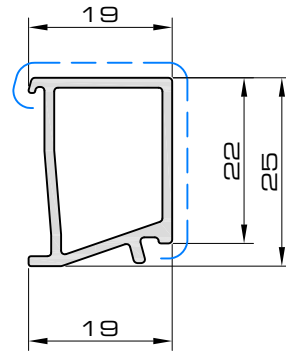

P-6b-021

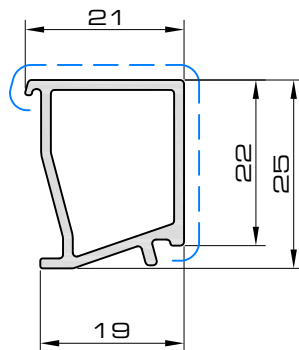

P-6b-023

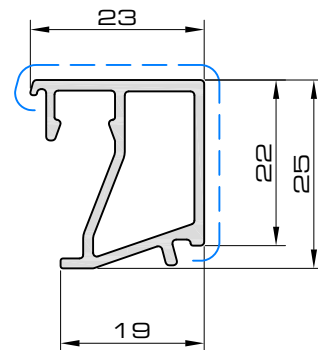

P-6b-025

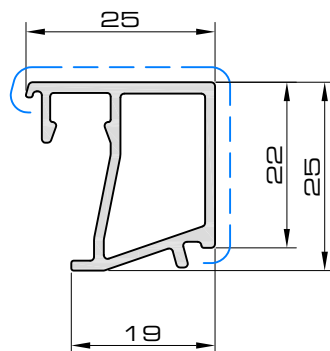

P-6b-027

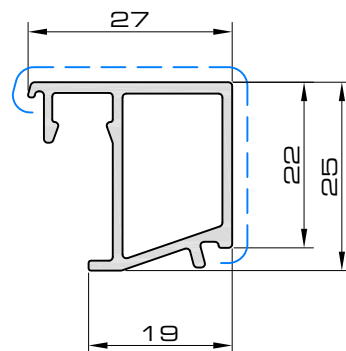

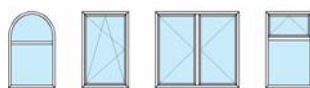

Hercules P02

profielen ■ profils ■ profiles

P-6b-029

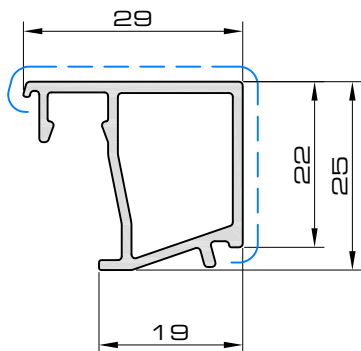

P-6b-031

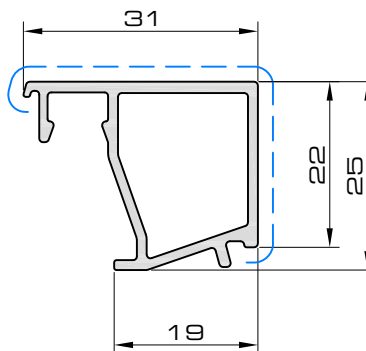

P-6b-033

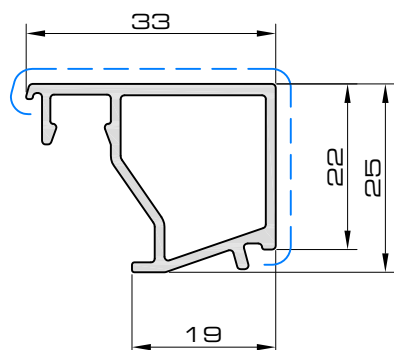

P-6b-035

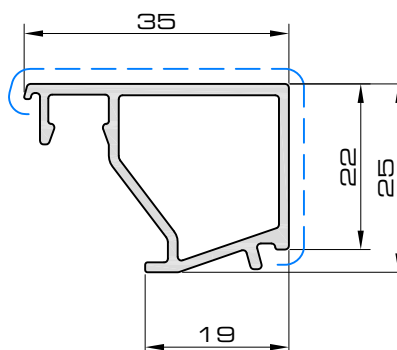

P-6b-037

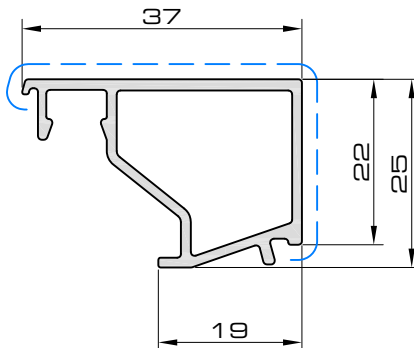



P-6b-039

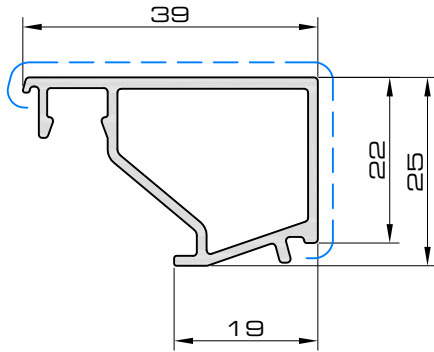

P-6b-042

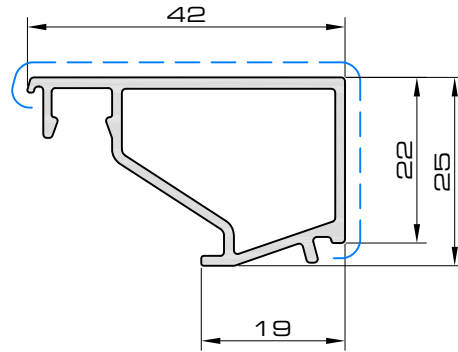

P-6b-043

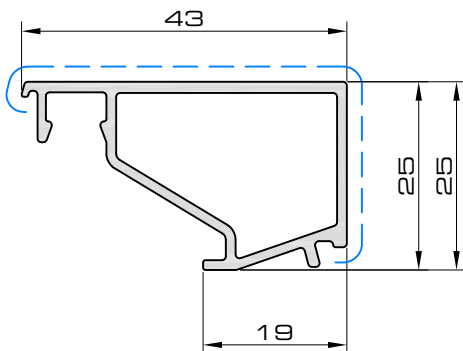

P-6b-045

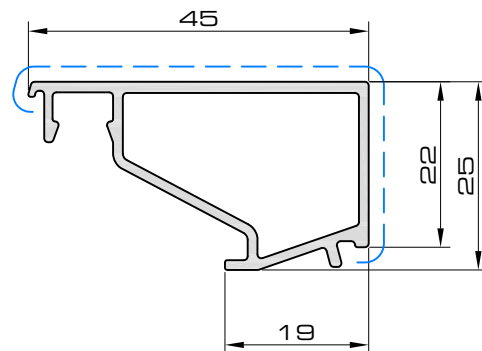

P-6b-048

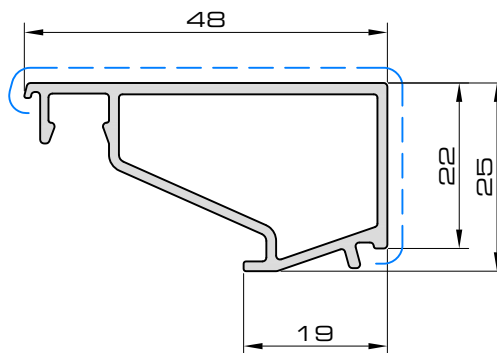

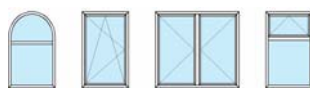

Hercules P02

profielen ■ profils ■ profiles

P-6f-028

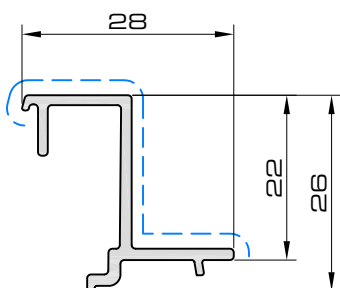

P-6f-032

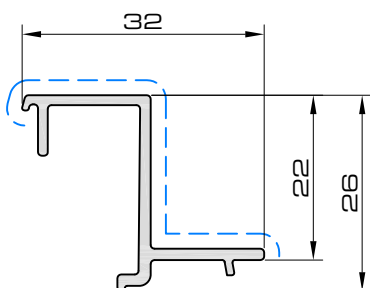

P-6f-036

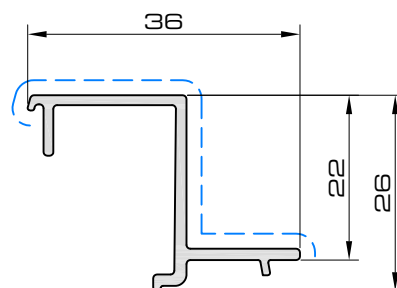

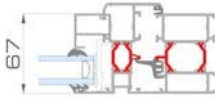

	of / ou / or			of / ou / or	
5		P-6b-048	A-GS-308	A-GS-100	A-GS-110
6		P-6b-048	A-GS-306	A-GS-100	A-GS-110
7		P-6b-048	A-GS-305	A-GS-100	A-GS-110
8	P-6s-045	P-6b-045	A-GS-308	A-GS-100	A-GS-110
9	P-6s-045	P-6b-045	A-GS-306	A-GS-100	A-GS-110
10	P-6s-045	P-6b-045	A-GS-305	A-GS-100	A-GS-110
11	P-6s-045	P-6b-045	A-GS-304	A-GS-100	A-GS-110
12	P-6s-043	P-6b-043	A-GS-305	A-GS-100	A-GS-110
13	P-6s-043	P-6b-043	A-GS-304	A-GS-100	A-GS-110
14		P-6b-042	A-GS-304	A-GS-100	A-GS-110
	P-6s-041		A-GS-305	A-GS-100	A-GS-110
15		P-6b-039	A-GS-306	A-GS-100	A-GS-110
	P-6s-041		A-GS-304	A-GS-100	A-GS-110
16	P-6s-039	P-6b-039	A-GS-305	A-GS-100	A-GS-110
17	P-6s-039	P-6b-039	A-GS-304	A-GS-100	A-GS-110
18	P-6s-037	P-6b-037	A-GS-305	A-GS-100	A-GS-110
19	P-6s-037	P-6b-037	A-GS-304	A-GS-100	A-GS-110
20	P-6s-035	P-6b-035	A-GS-305	A-GS-100	A-GS-110
21	P-6s-035	P-6b-035	A-GS-304	A-GS-100	A-GS-110
22	P-6s-033	P-6b-033	A-GS-305	A-GS-100	A-GS-110
23	P-6s-033	P-6b-033	A-GS-304	A-GS-100	A-GS-110
24	P-6s-031	P-6b-031	A-GS-305	A-GS-100	A-GS-110
25	P-6s-031	P-6b-031	A-GS-304	A-GS-100	A-GS-110
26	P-6s-029	P-6b-029	A-GS-305	A-GS-100	A-GS-110
27	P-6s-029	P-6b-029	A-GS-304	A-GS-100	A-GS-110
28	P-6s-027	P-6b-027	A-GS-305	A-GS-100	A-GS-110
29	P-6s-027	P-6b-027	A-GS-304	A-GS-100	A-GS-110
30	P-6s-025	P-6b-025	A-GS-305	A-GS-100	A-GS-110
31	P-6s-025	P-6b-025	A-GS-304	A-GS-100	A-GS-110
32	P-6s-023	P-6b-023	A-GS-305	A-GS-100	A-GS-110
33	P-6s-023	P-6b-023	A-GS-304	A-GS-100	A-GS-110
34	P-6s-021	P-6b-021	A-GS-305	A-GS-100	A-GS-110
35	P-6s-021	P-6b-021	A-GS-304	A-GS-100	A-GS-110
36	P-6s-019	P-6b-019	A-GS-305	A-GS-100	A-GS-110
37	P-6s-019	P-6b-019	A-GS-304	A-GS-100	A-GS-110
38	P-6s-015	P-6b-015	A-GS-308	A-GS-100	A-GS-110
39	P-6s-015	P-6b-015	A-GS-306	A-GS-100	A-GS-110
40	P-6s-015	P-6b-015	A-GS-305	A-GS-100	A-GS-110
41	P-6s-015	P-6b-015	A-GS-304	A-GS-100	A-GS-110
42	P-6s-013		A-GS-305	A-GS-100	A-GS-110
43	P-6s-013		A-GS-304	A-GS-100	A-GS-110
44	P-6s-011		A-GS-305	A-GS-100	A-GS-110
45	P-6s-011		A-GS-304	A-GS-100	A-GS-110
46	P-6s-007		A-GS-308	A-GS-100	A-GS-110
47	P-6s-007		A-GS-306	A-GS-100	A-GS-110
48	P-6s-007		A-GS-305	A-GS-100	A-GS-110
49	P-6s-007		A-GS-304	A-GS-100	A-GS-110
50	P-6s-003		A-GS-308	A-GS-100	A-GS-110
51	P-6s-003		A-GS-306	A-GS-100	A-GS-110
52	P-6s-003		A-GS-305	A-GS-100	A-GS-110
53	P-6s-003		A-GS-304	A-GS-100	A-GS-110

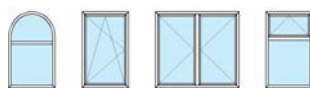

Hercules P02

profielen ■ profils ■ profiles



Variant!
Planea

	of / ou / or			of / ou / or	
14		P-6b-048	A-GS-308	A-GS-100	A-GS-110
15		P-6b-048	A-GS-306	A-GS-100	A-GS-110
16		P-6b-048	A-GS-305	A-GS-100	A-GS-110
17	P-6s-045	P-6b-045	A-GS-308	A-GS-100	A-GS-110
18	P-6s-045	P-6b-045	A-GS-306	A-GS-100	A-GS-110
19	P-6s-045	P-6b-045	A-GS-305	A-GS-100	A-GS-110
20	P-6s-045	P-6b-045	A-GS-304	A-GS-100	A-GS-110
21	P-6s-043	P-6b-043	A-GS-305	A-GS-100	A-GS-110
22	P-6s-043	P-6b-043	A-GS-304	A-GS-100	A-GS-110
23		P-6b-042	A-GS-304	A-GS-100	A-GS-110
	P-6s-041		A-GS-305	A-GS-100	A-GS-110
24		P-6b-039	A-GS-306	A-GS-100	A-GS-110
	P-6s-041		A-GS-304	A-GS-100	A-GS-110
25	P-6s-039	P-6b-039	A-GS-305	A-GS-100	A-GS-110
26	P-6s-039	P-6b-039	A-GS-304	A-GS-100	A-GS-110
27	P-6s-037	P-6b-037	A-GS-305	A-GS-100	A-GS-110
28	P-6s-037	P-6b-037	A-GS-304	A-GS-100	A-GS-110
29	P-6s-035	P-6b-035	A-GS-305	A-GS-100	A-GS-110
30	P-6s-035	P-6b-035	A-GS-304	A-GS-100	A-GS-110
31	P-6s-033	P-6b-033	A-GS-305	A-GS-100	A-GS-110
32	P-6s-033	P-6b-033	A-GS-304	A-GS-100	A-GS-110
33	P-6s-031	P-6b-031	A-GS-305	A-GS-100	A-GS-110
34	P-6s-031	P-6b-031	A-GS-304	A-GS-100	A-GS-110
35	P-6s-029	P-6b-029	A-GS-305	A-GS-100	A-GS-110
36	P-6s-029	P-6b-029	A-GS-304	A-GS-100	A-GS-110
37	P-6s-027	P-6b-027	A-GS-305	A-GS-100	A-GS-110
38	P-6s-027	P-6b-027	A-GS-304	A-GS-100	A-GS-110
39	P-6s-025	P-6b-025	A-GS-305	A-GS-100	A-GS-110
40	P-6s-025	P-6b-025	A-GS-304	A-GS-100	A-GS-110
41	P-6s-023	P-6b-023	A-GS-305	A-GS-100	A-GS-110
42	P-6s-023	P-6b-023	A-GS-304	A-GS-100	A-GS-110
43	P-6s-021	P-6b-021	A-GS-305	A-GS-100	A-GS-110
44	P-6s-021	P-6b-021	A-GS-304	A-GS-100	A-GS-110
45	P-6s-019	P-6b-019	A-GS-305	A-GS-100	A-GS-110
46	P-6s-019	P-6b-019	A-GS-304	A-GS-100	A-GS-110
47	P-6s-015	P-6b-015	A-GS-308	A-GS-100	A-GS-110
48	P-6s-015	P-6b-015	A-GS-306	A-GS-100	A-GS-110
49	P-6s-015	P-6b-015	A-GS-305	A-GS-100	A-GS-110
50	P-6s-015	P-6b-015	A-GS-304	A-GS-100	A-GS-110
51	P-6s-013		A-GS-305	A-GS-100	A-GS-110
52	P-6s-013		A-GS-304	A-GS-100	A-GS-110
53	P-6s-011		A-GS-305	A-GS-100	A-GS-110
54	P-6s-011		A-GS-304	A-GS-100	A-GS-110
55	P-6s-007		A-GS-308	A-GS-100	A-GS-110
56	P-6s-007		A-GS-306	A-GS-100	A-GS-110
57	P-6s-007		A-GS-305	A-GS-100	A-GS-110
58	P-6s-007		A-GS-304	A-GS-100	A-GS-110
59	P-6s-003		A-GS-308	A-GS-100	A-GS-110
60	P-6s-003		A-GS-306	A-GS-100	A-GS-110
61	P-6s-003		A-GS-305	A-GS-100	A-GS-110
62	P-6s-003		A-GS-304	A-GS-100	A-GS-110



				of / ou / or
17	P-6f-036	A-GS-308	A-GS-100	A-GS-110
18	P-6f-036	A-GS-306	A-GS-100	A-GS-110
19	P-6f-036	A-GS-305	A-GS-100	A-GS-110
20	P-6f-036	A-GS-304	A-GS-100	A-GS-110
21	P-6f-032	A-GS-308	A-GS-100	A-GS-110
22	P-6f-032	A-GS-306	A-GS-100	A-GS-110
23	P-6f-032	A-GS-305	A-GS-100	A-GS-110
24	P-6f-032	A-GS-304	A-GS-100	A-GS-110
25	P-6f-028	A-GS-308	A-GS-100	A-GS-110
26	P-6f-028	A-GS-306	A-GS-100	A-GS-110
27	P-6f-028	A-GS-305	A-GS-100	A-GS-110
28	P-6f-028	A-GS-304	A-GS-100	A-GS-110

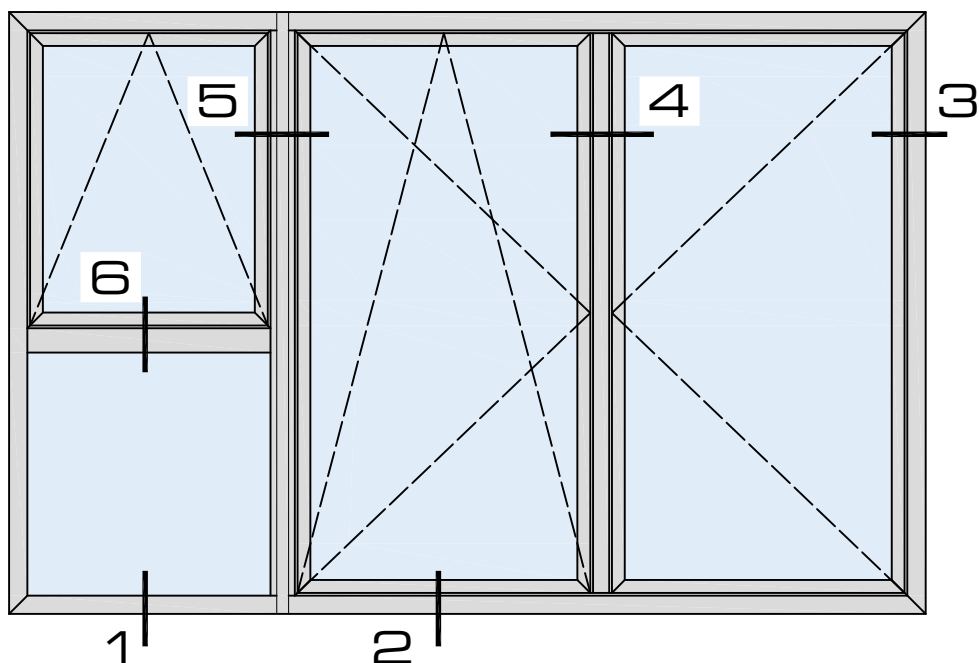
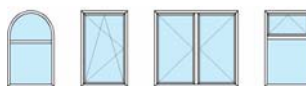

1: p.146

2: p.152

3: p.156

4: p.158

5: p.161

6: p.163

7: p.168

8: p.176

9: p.180

10: p.183

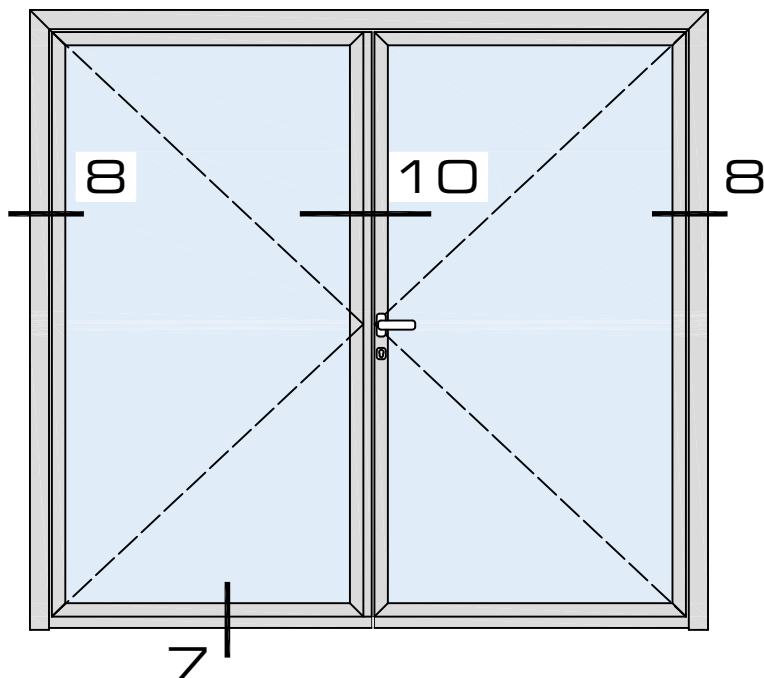
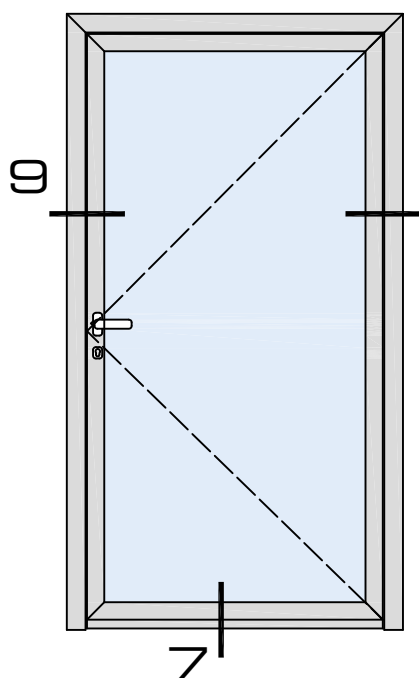

overzicht

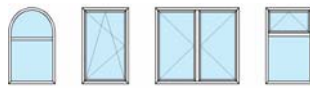

HerCules P02

doorsneden ■ coupes ■ sections

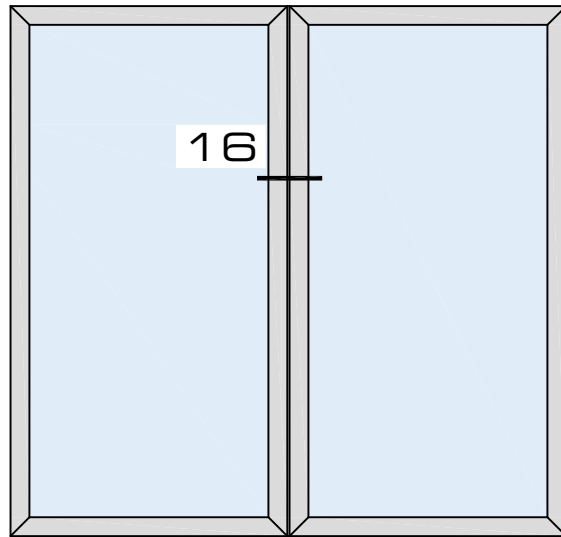
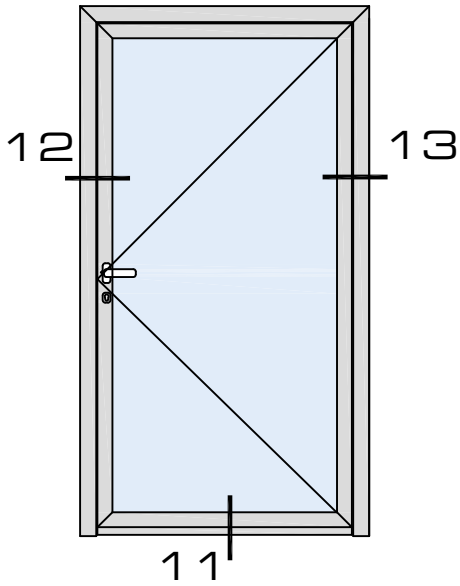

11: p.186

12: p.192

13: p.195

14: p.198

15: p.200

16: p.201

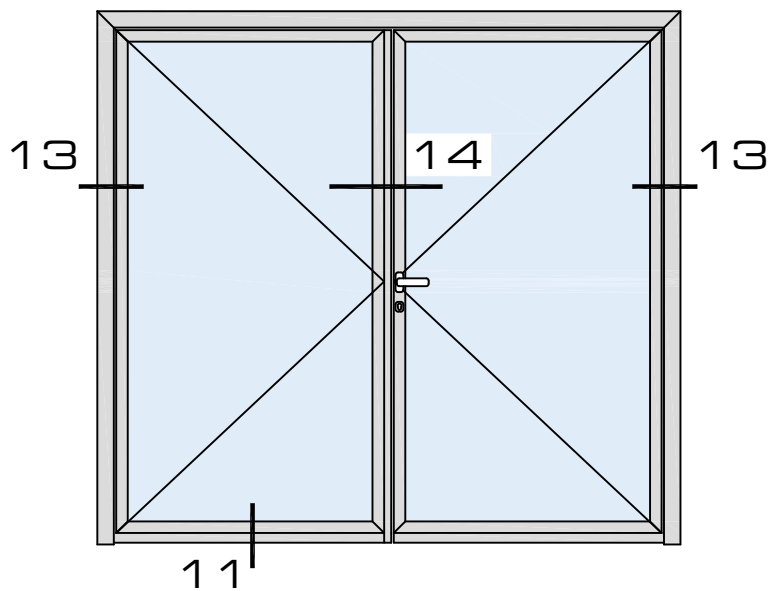
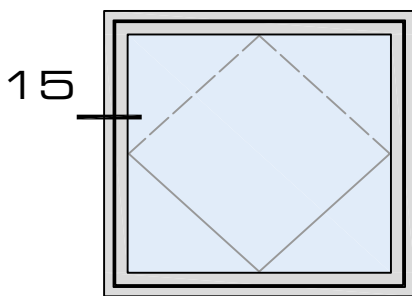

overzicht

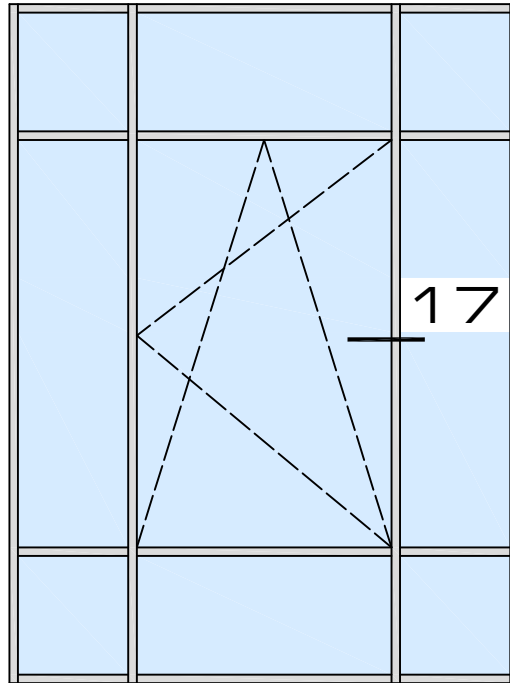

17: p.202

overzicht

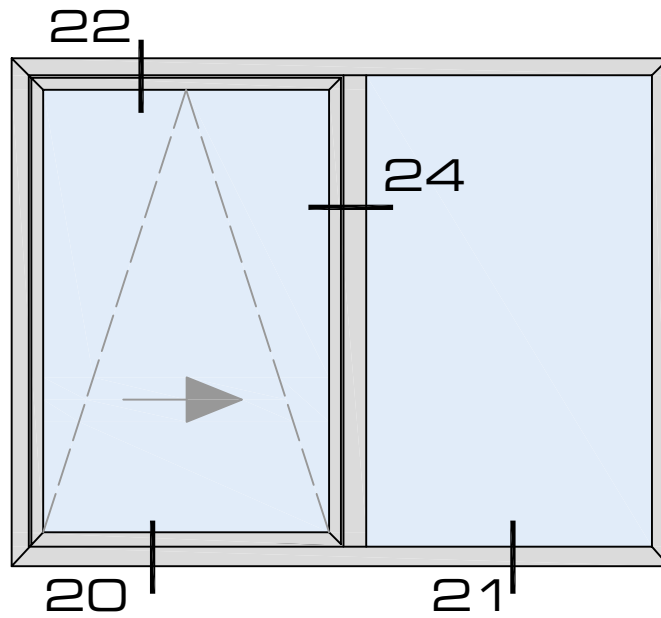
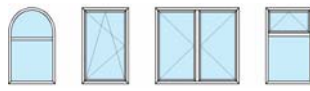

20: p.203

21: p.204

22: p.205

23: p.206

24: p.207

1a

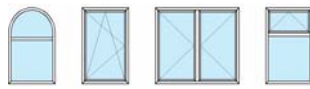

doorsneden ■ coupes ■ sections

Hercules P02

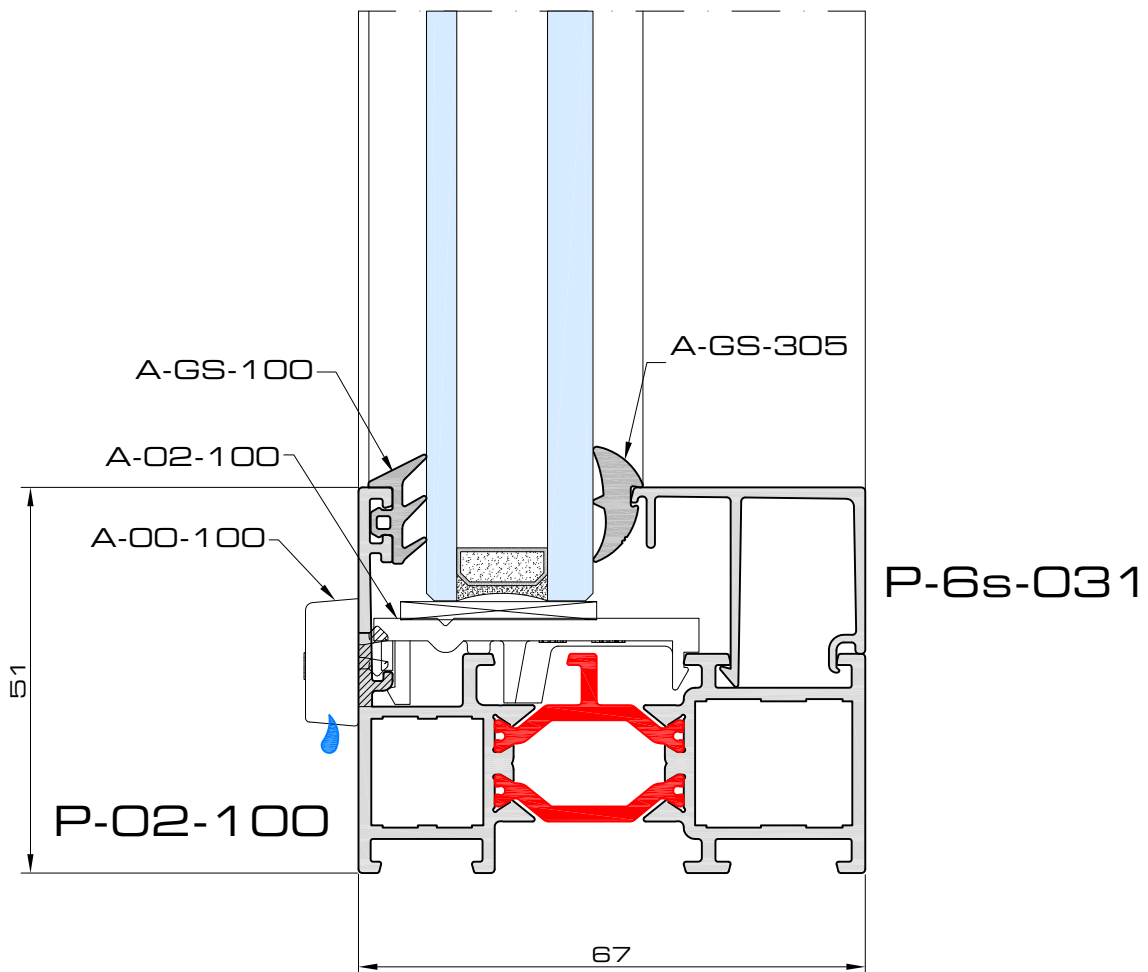
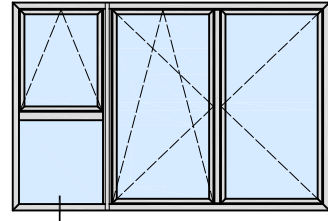

door1a

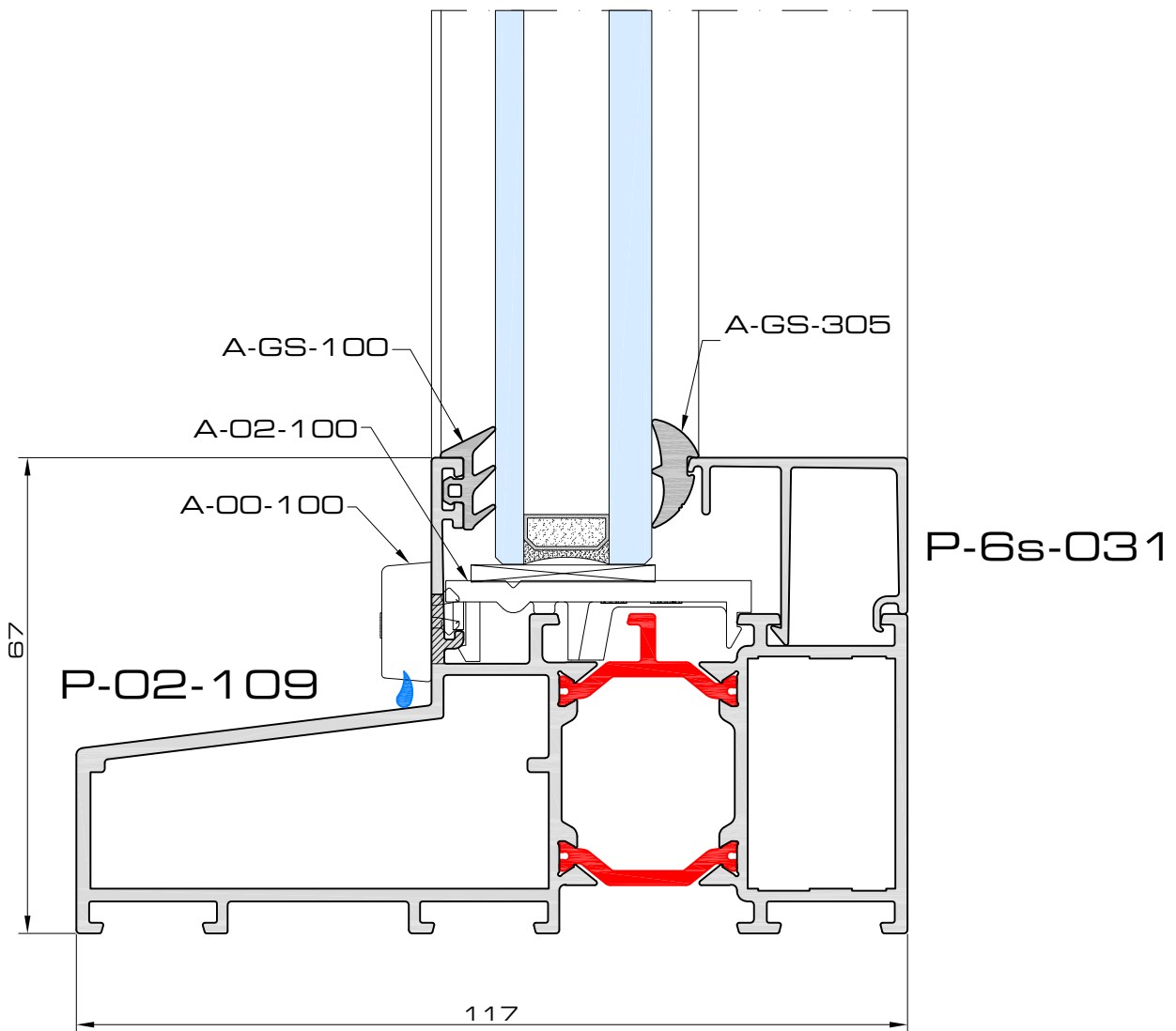
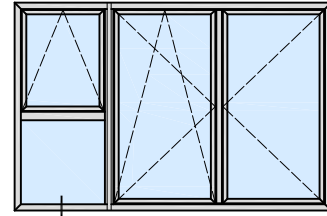
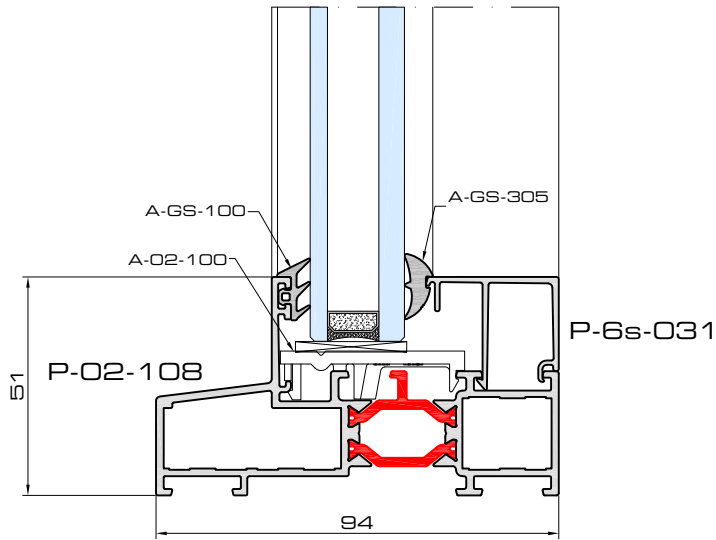

door1b

1c

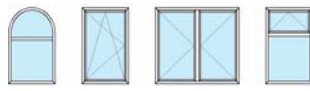

doorsneden ■ coupes ■ sections

Hercules P02

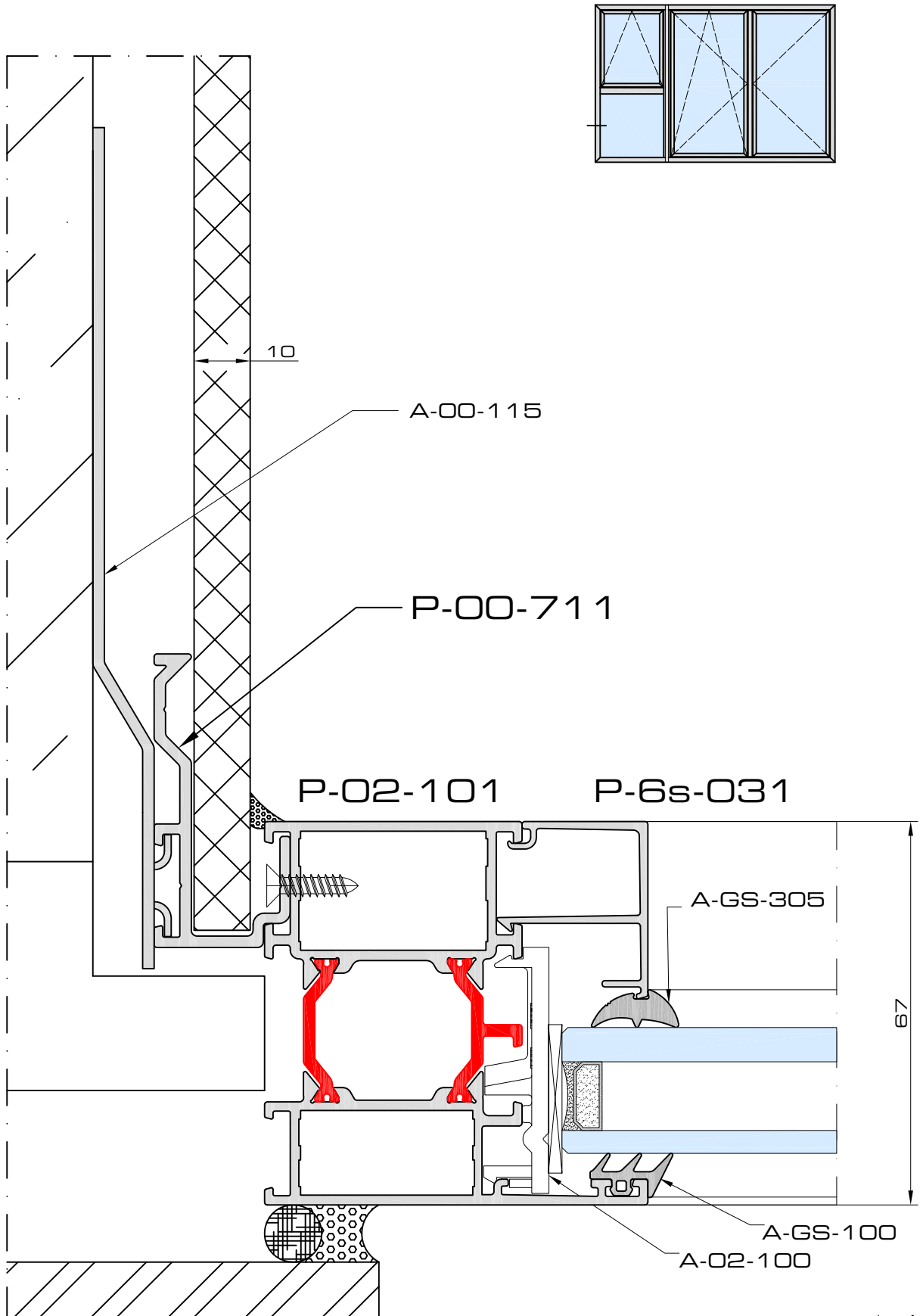

door1c

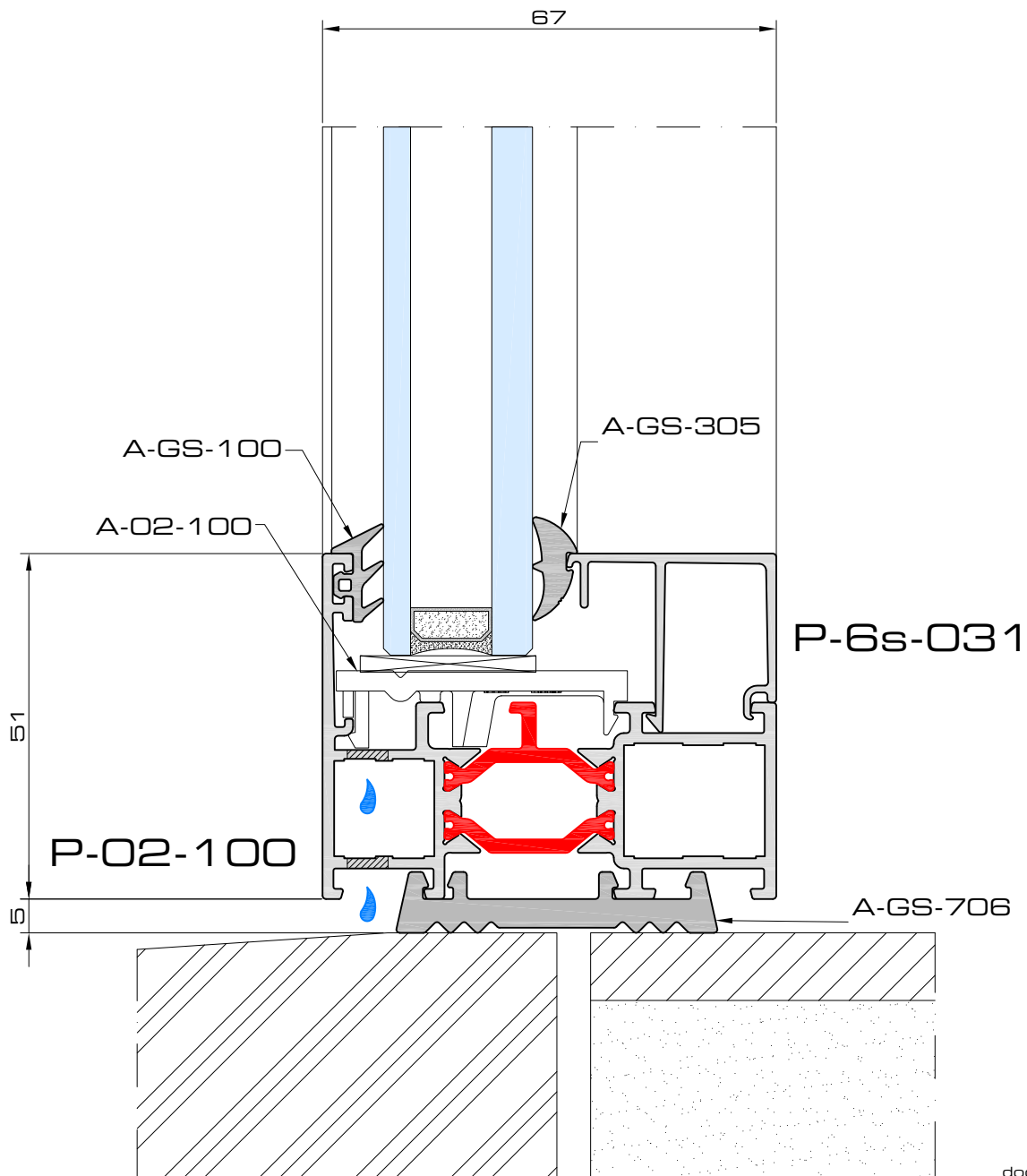
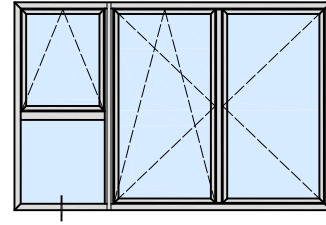
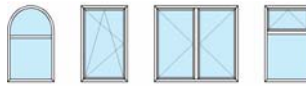

door1d

1e

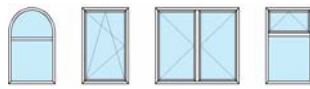

doorsneden ■ coupes ■ sections

Hercules P02

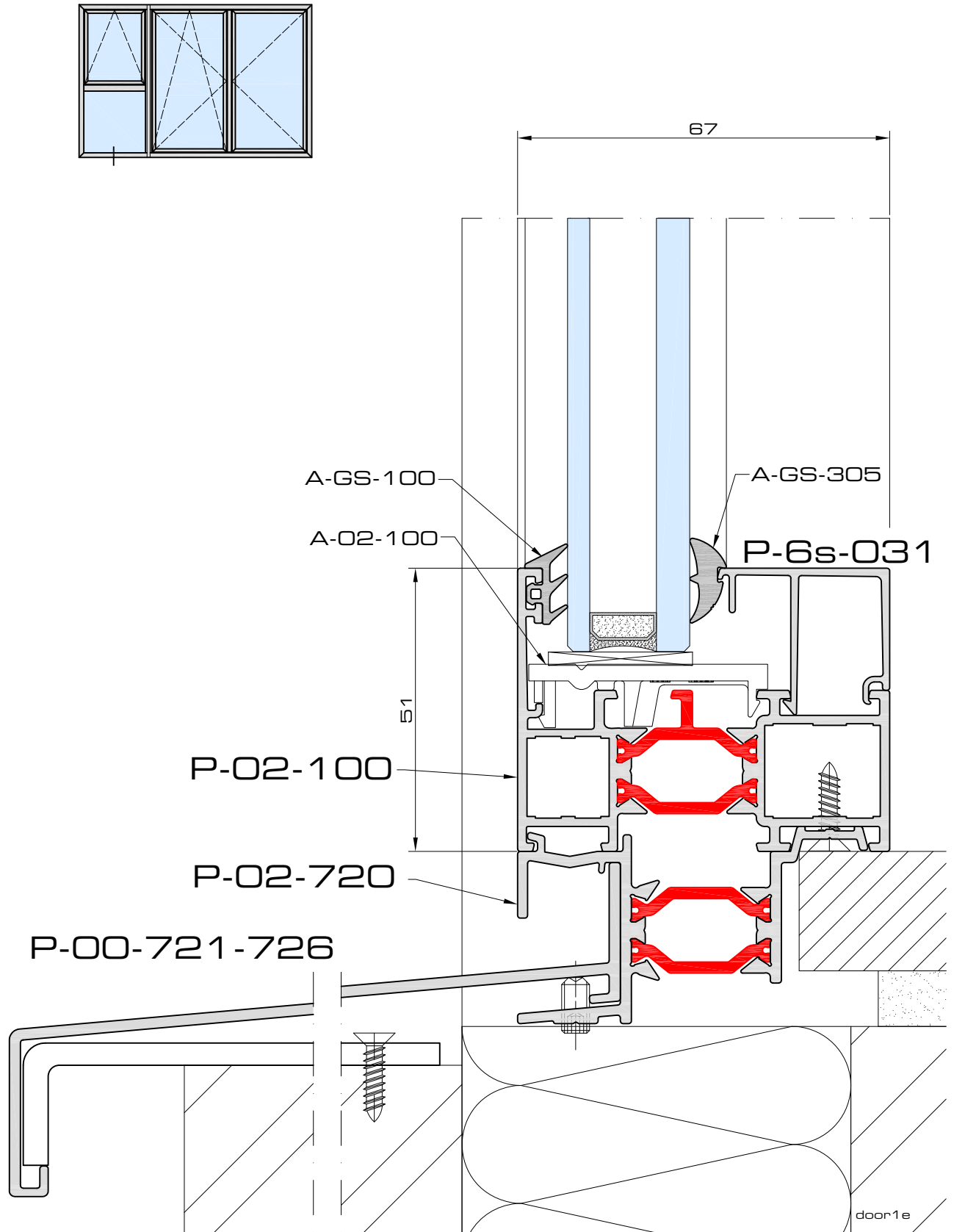

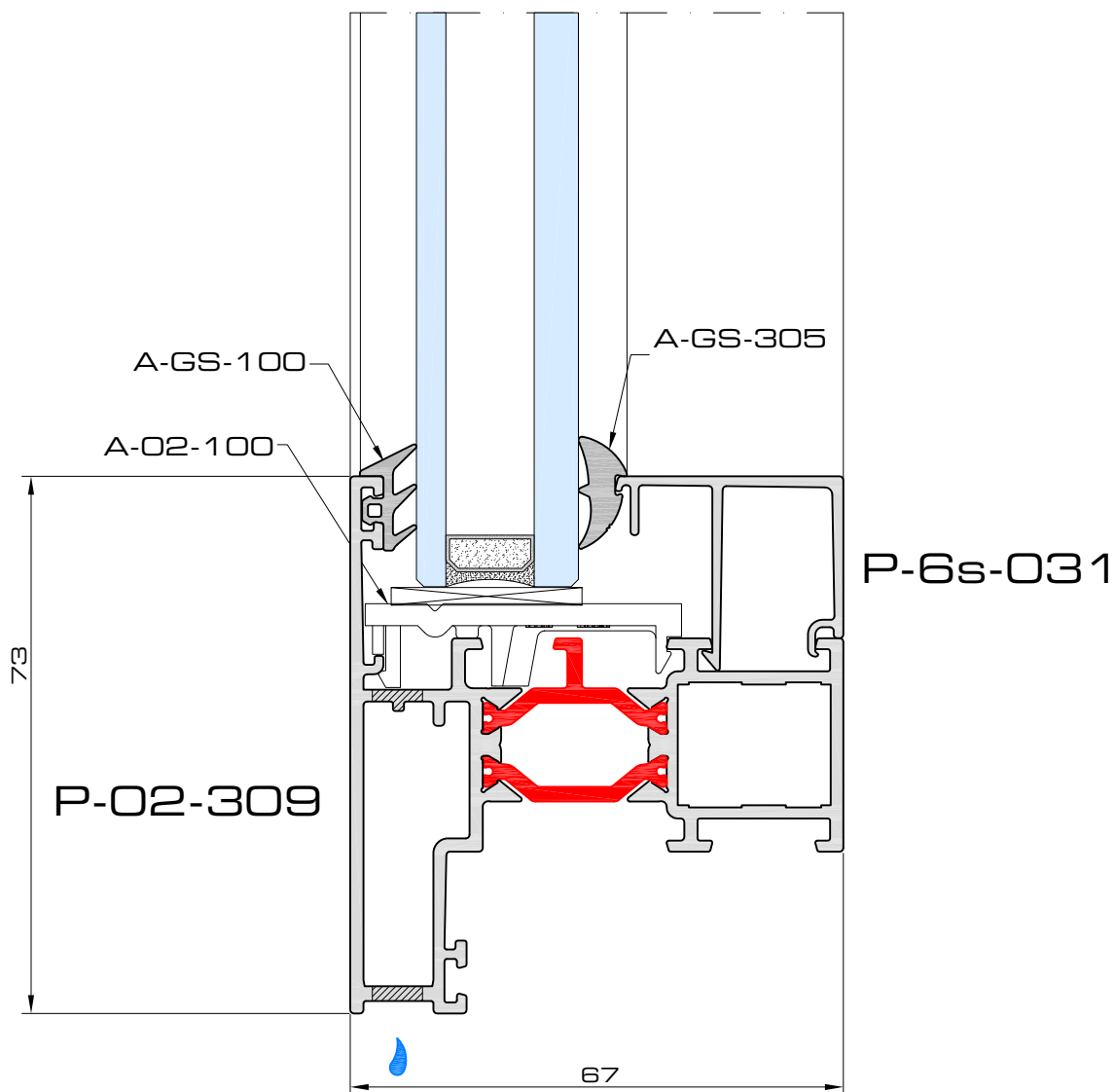
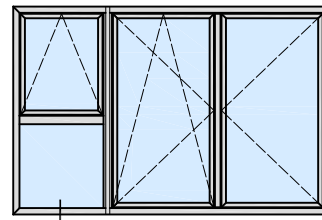
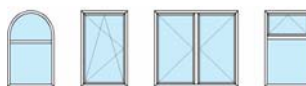

door1f

2a

doorsneden ■ coupes ■ sections

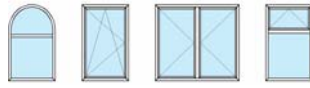

Hercules P02

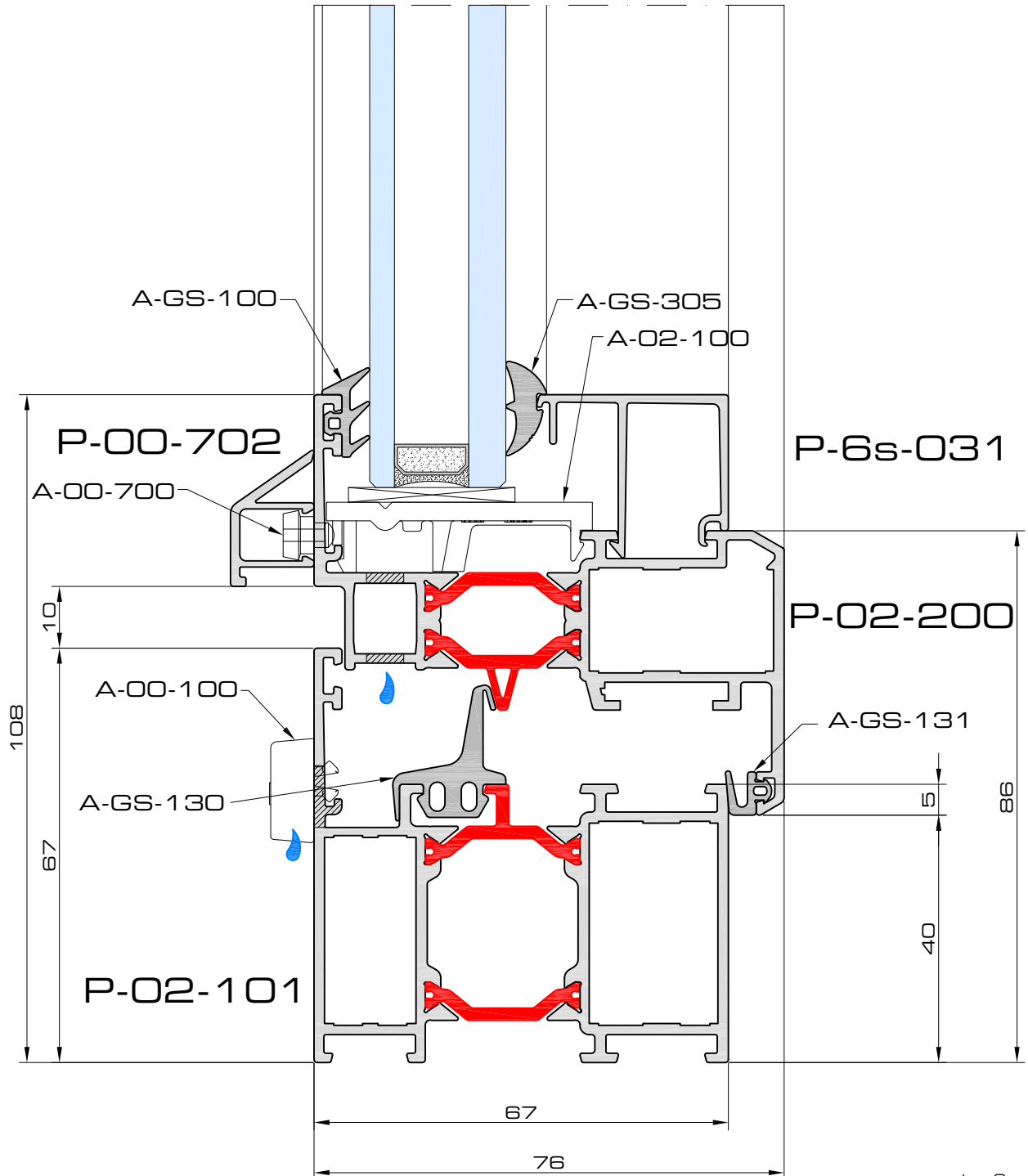
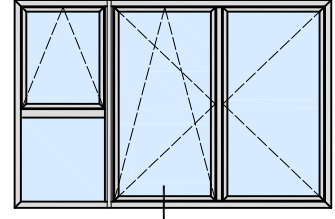

door2a

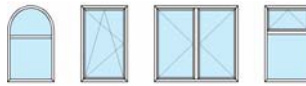

Variant!
Planea

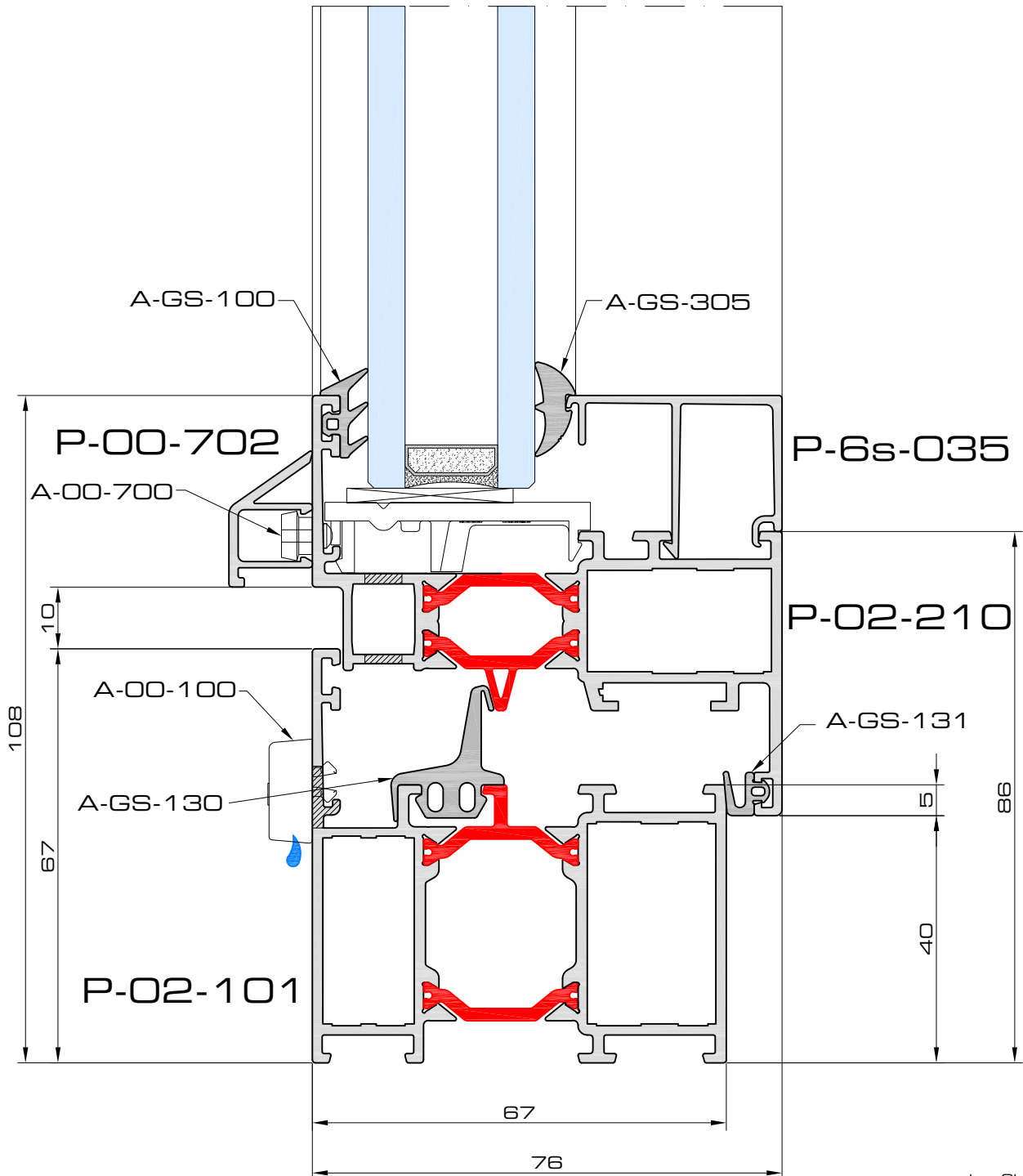
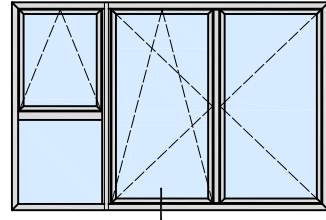

door2b

2c

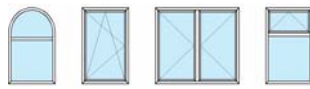

Hercules P02

doorsneden ■ coupes ■ sections

Variant!
Linea

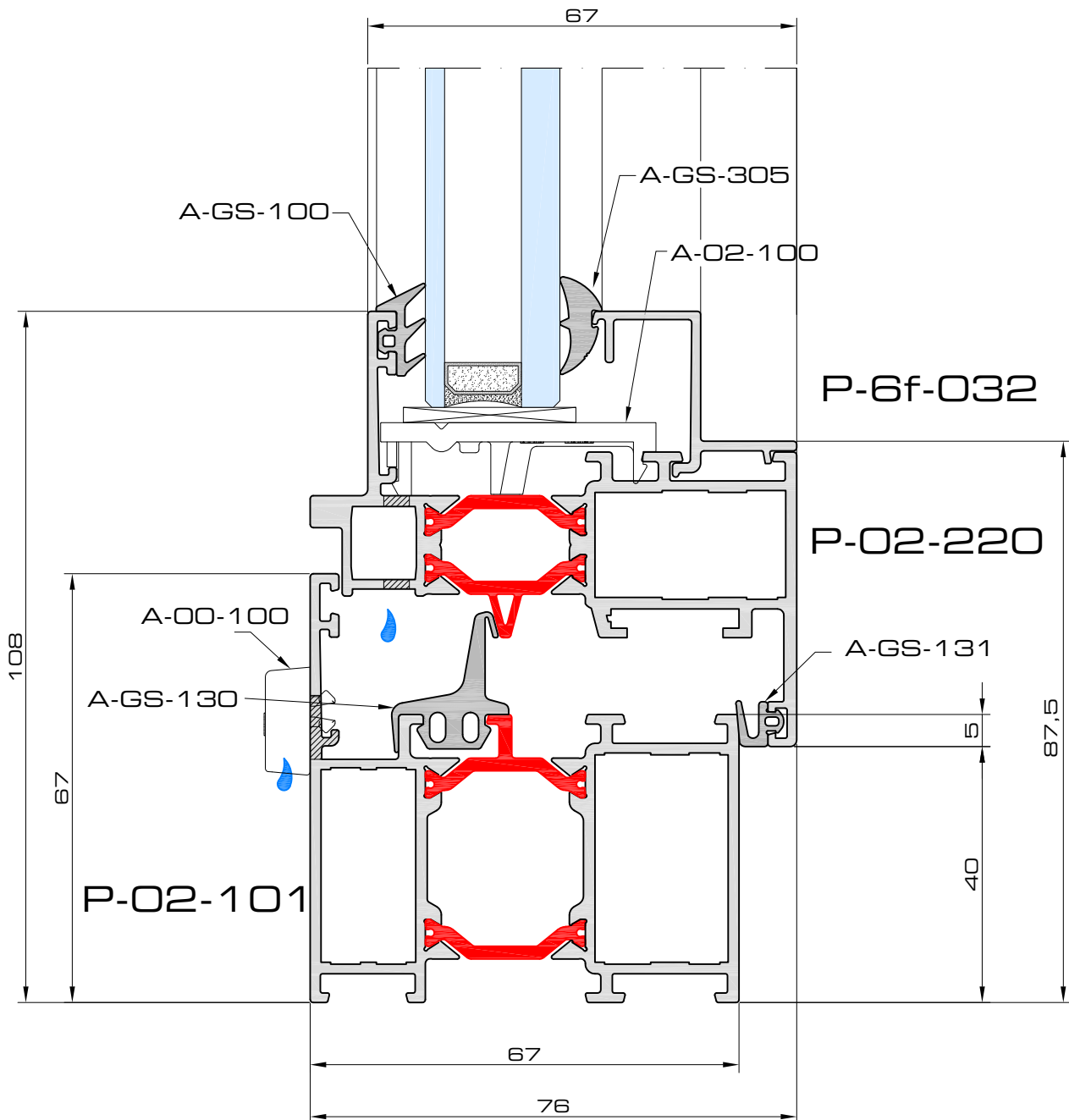
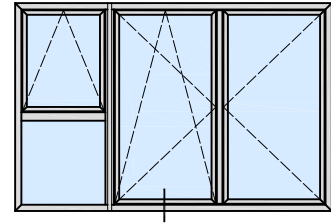

door2c



Variant!
PVC-nut

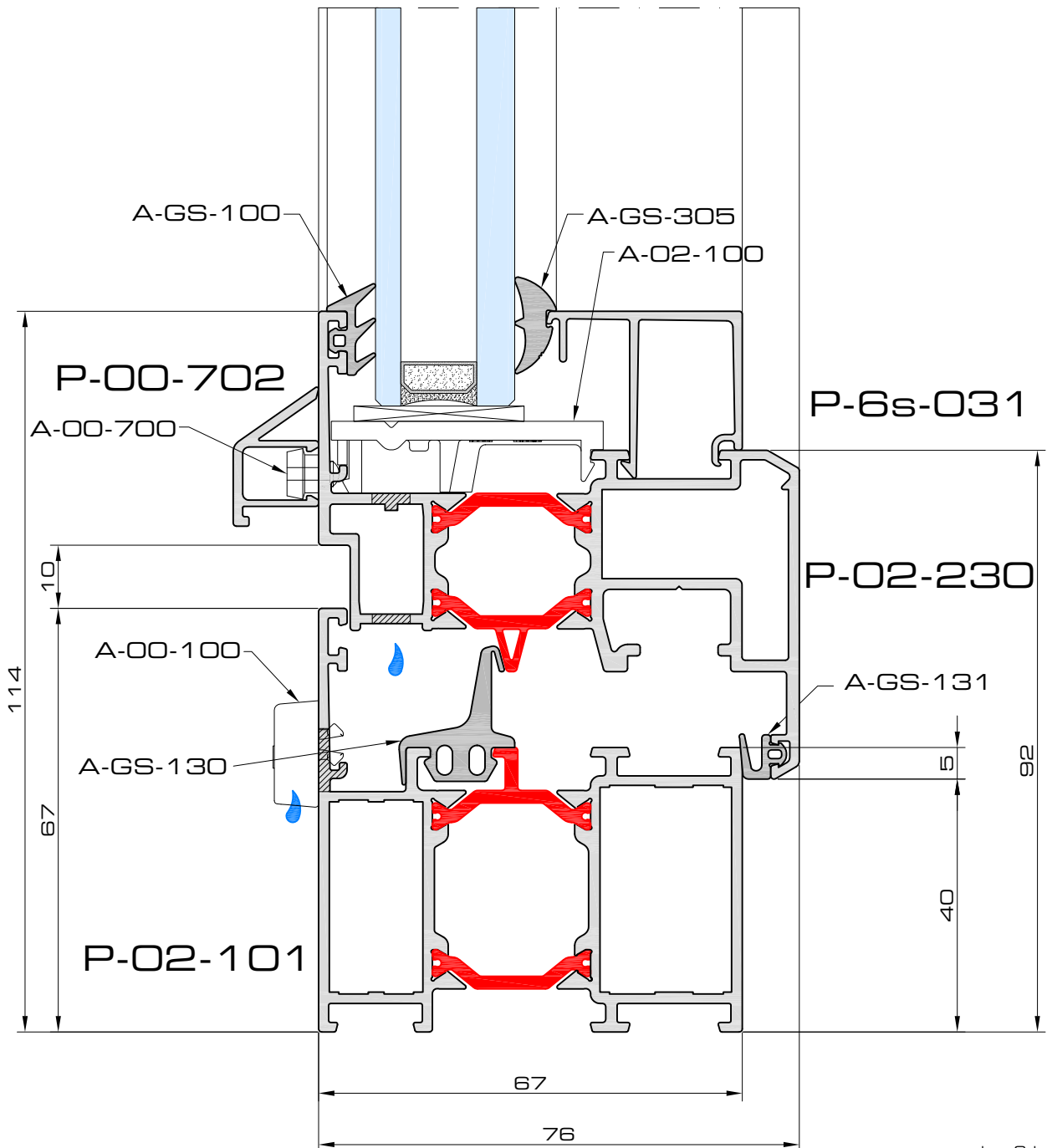
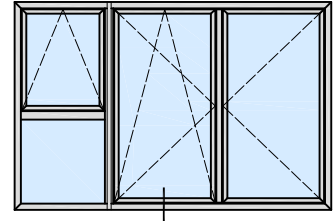

door2d

3a

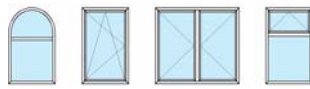

Hercules P02

doorsneden ■ coupes ■ sections

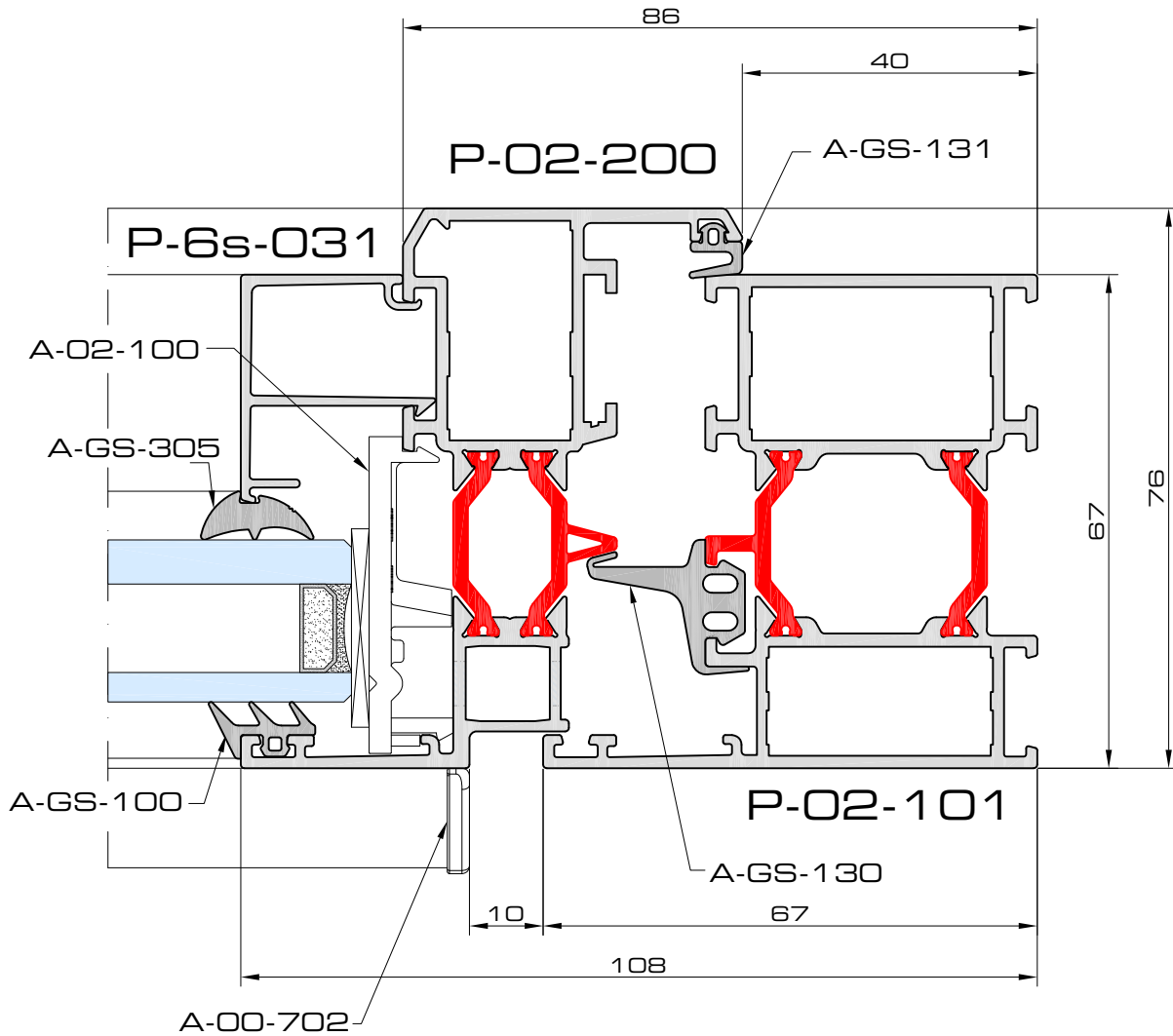
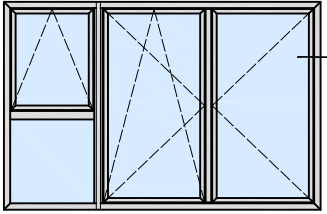

door3

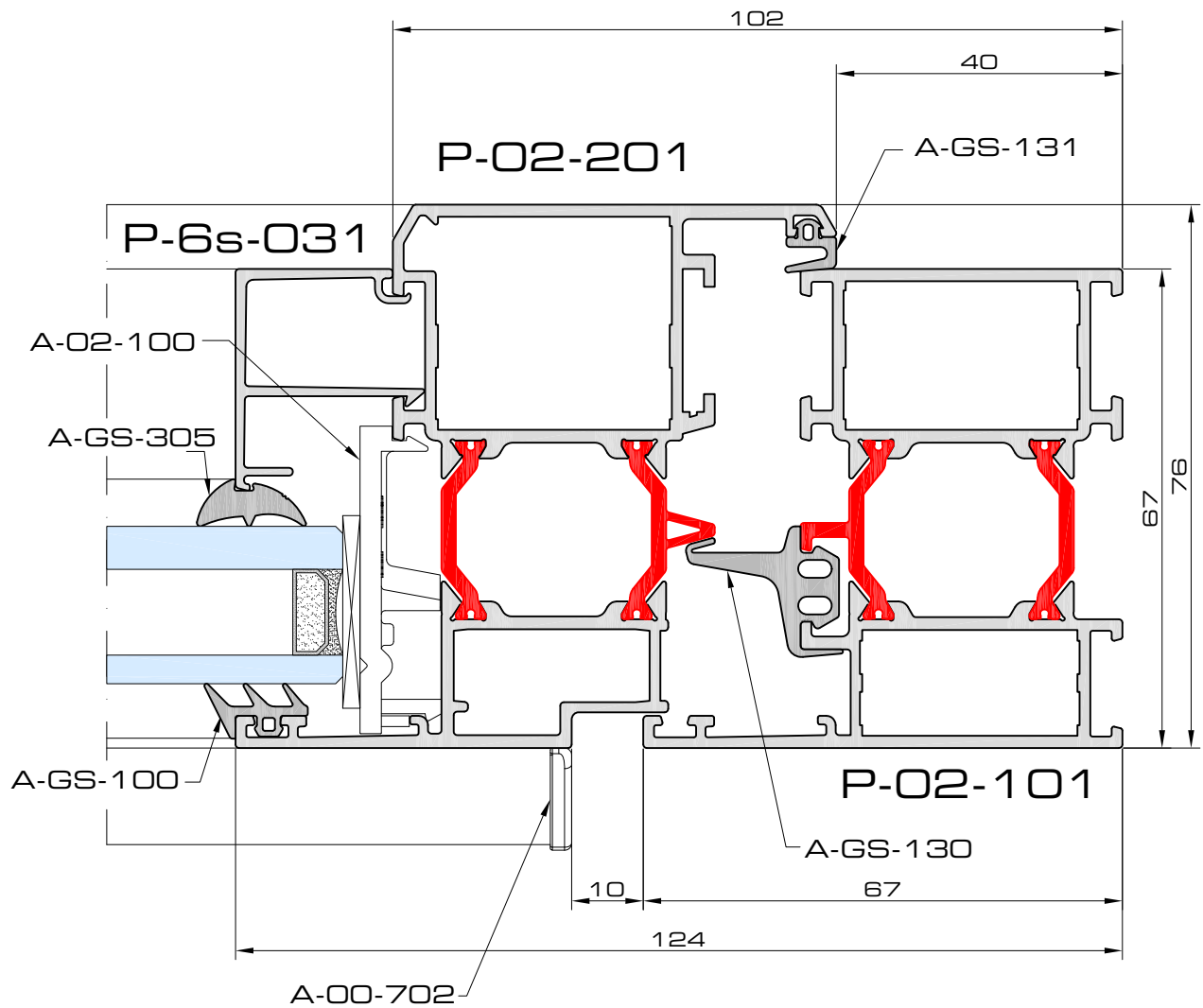
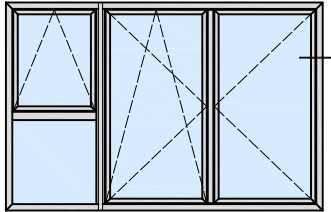

door3b

4a

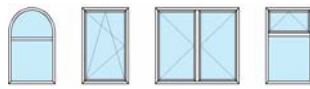

Hercules P02

doorsneden ■ coupes ■ sections

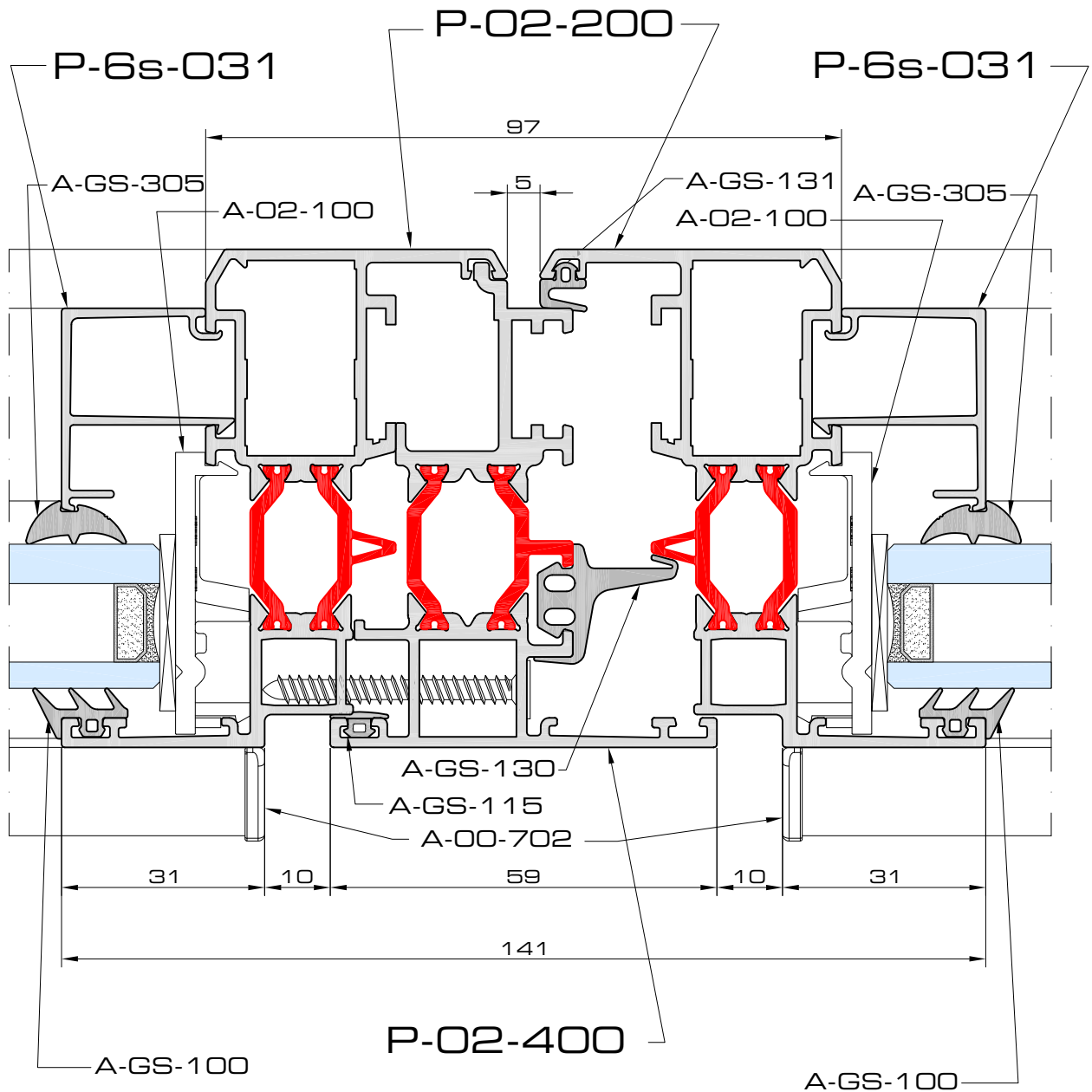
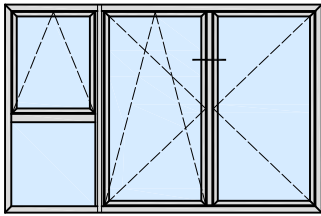

door4

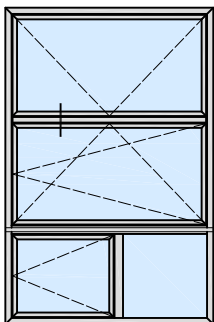
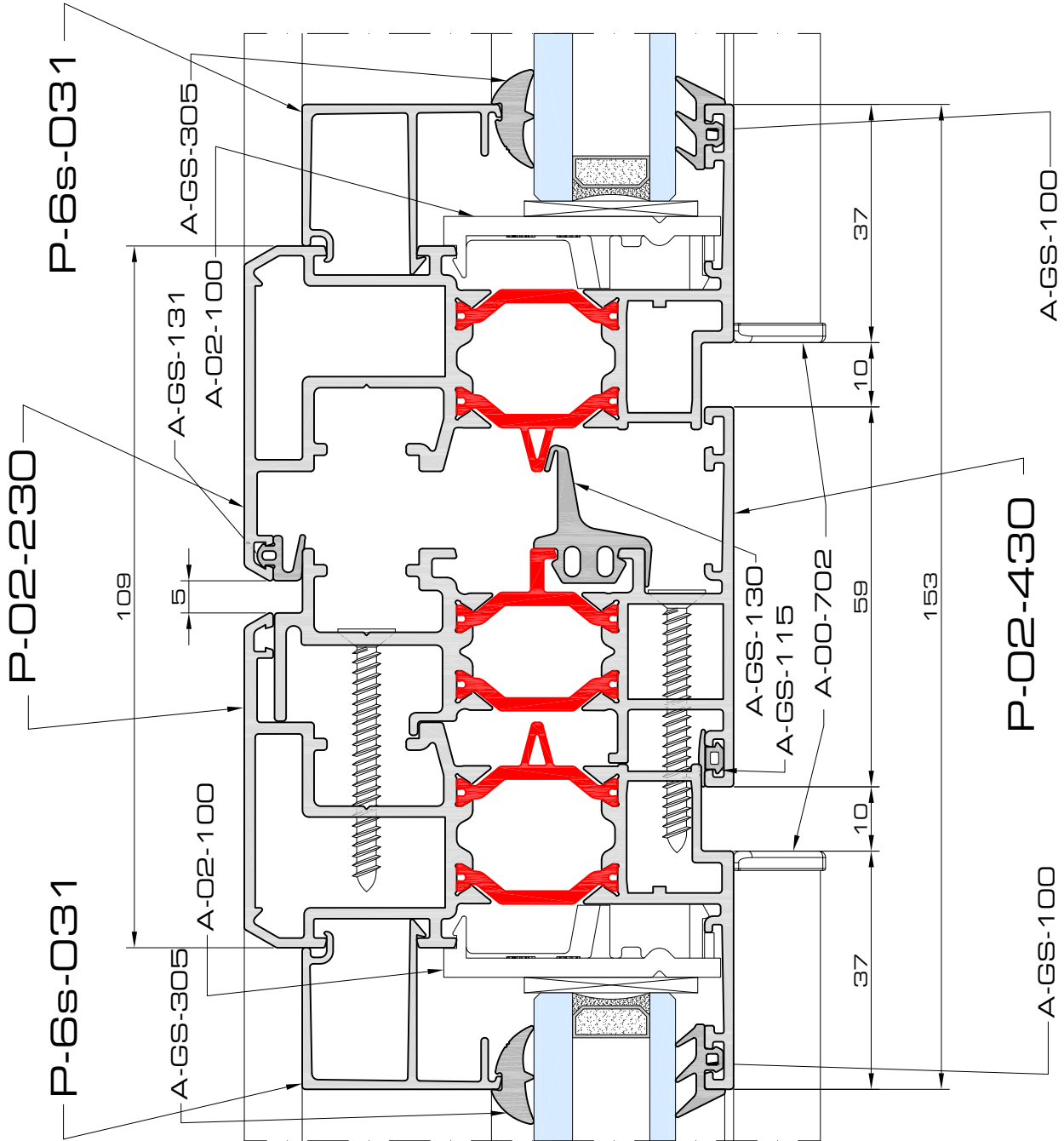
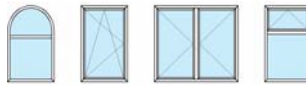

Variant!
PVC-nut

door4b

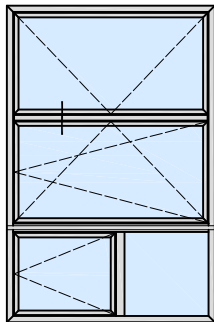
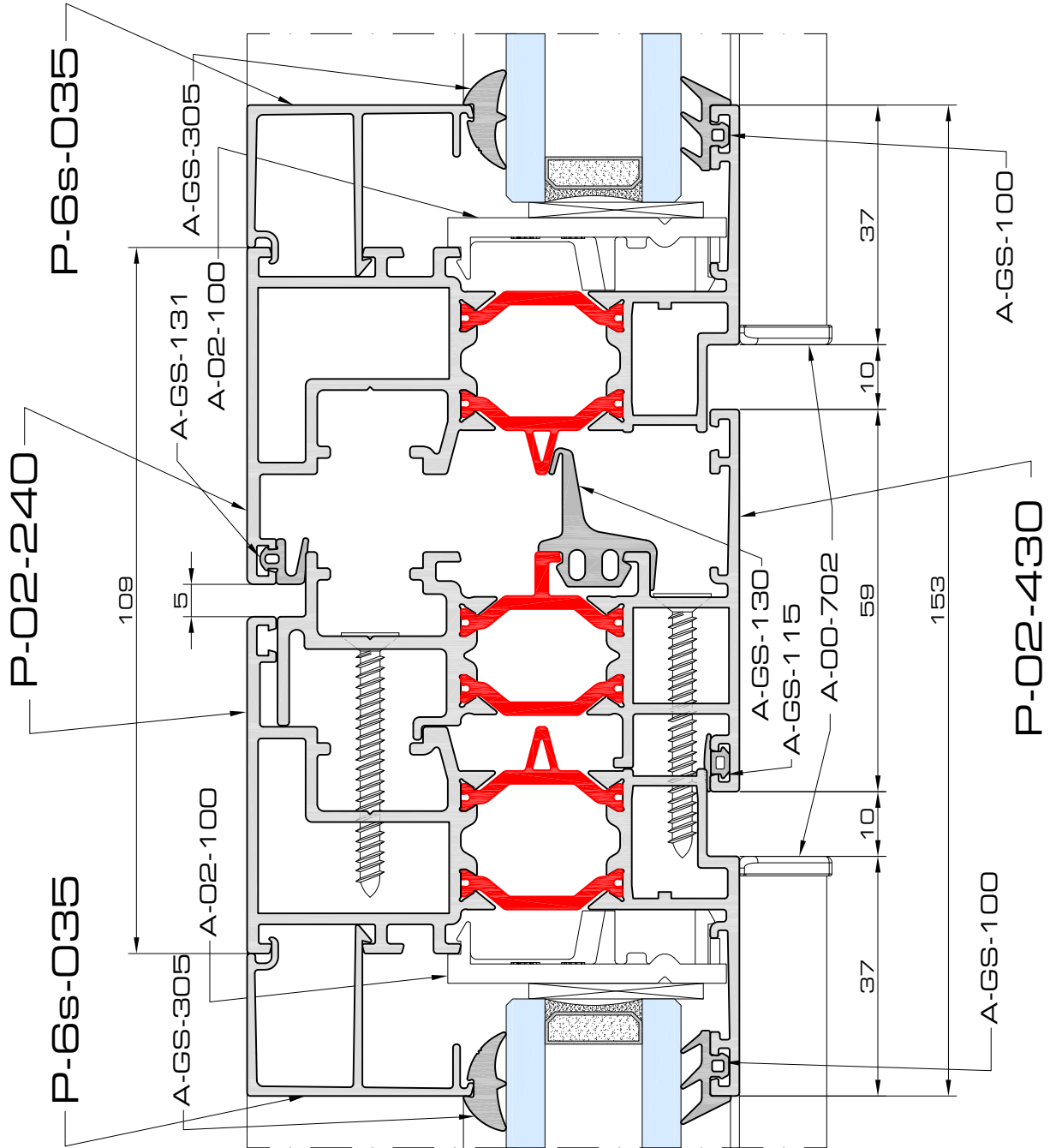
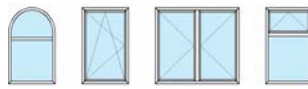

Variante!
PVC-nut

door4c

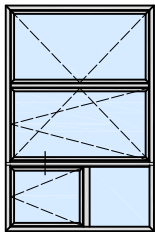
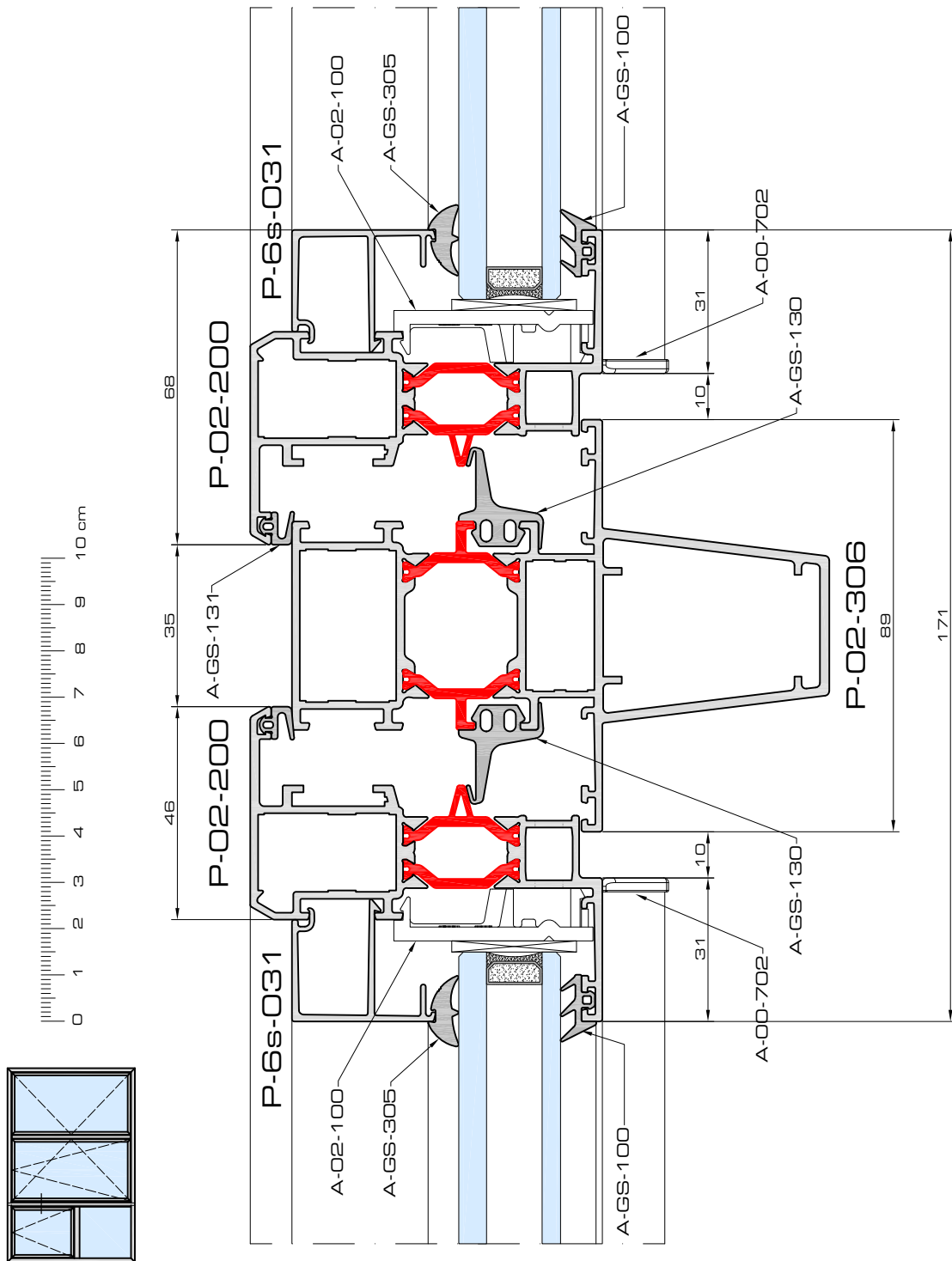
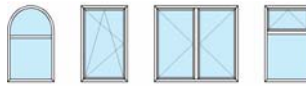

door5

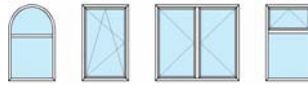

Variant! PVC-nut

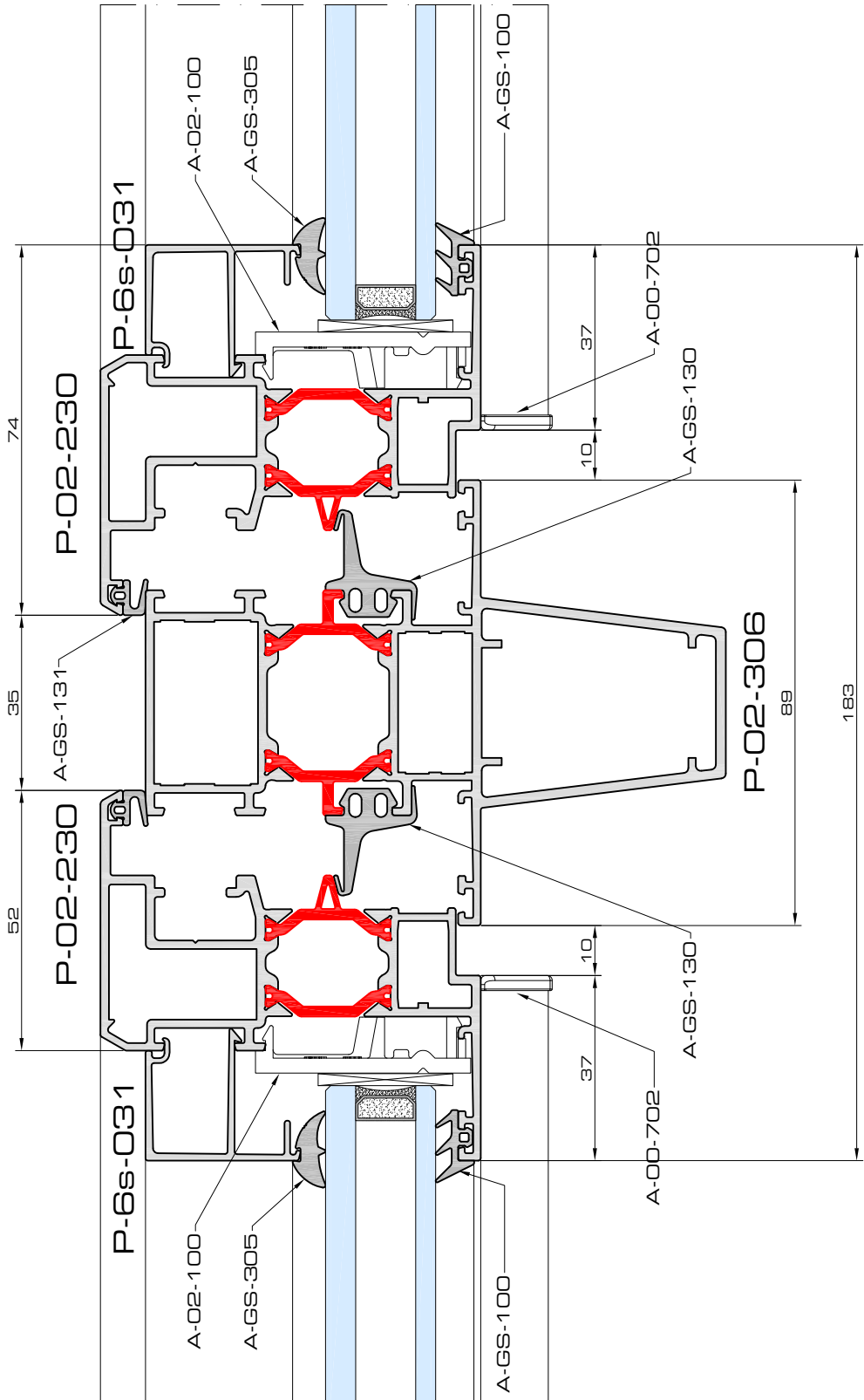
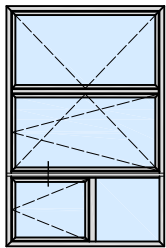

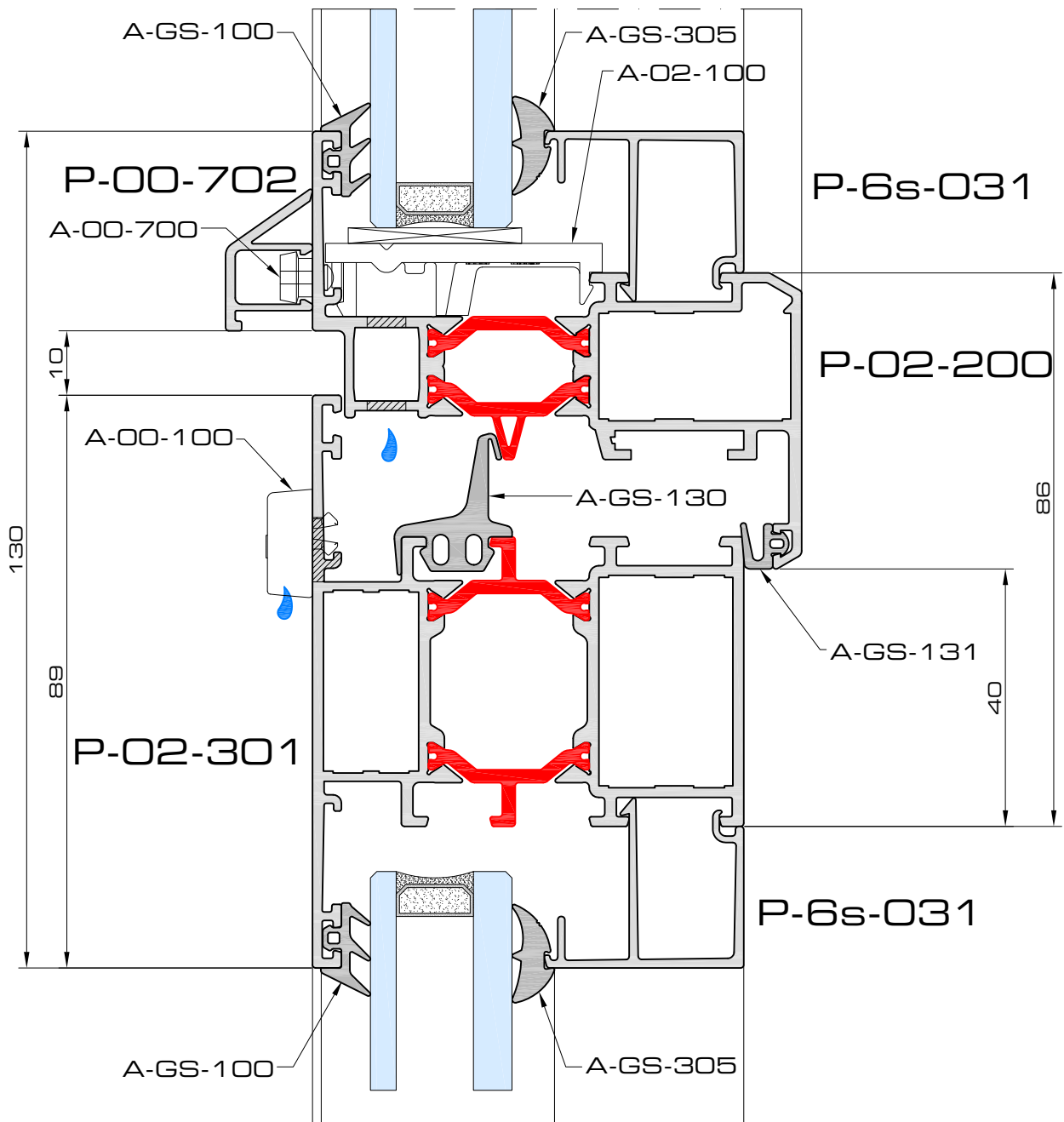
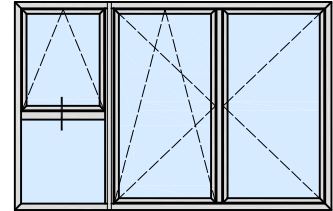

door6a

6b

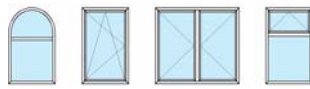

Hercules P02

doorsneden ■ coupes ■ sections

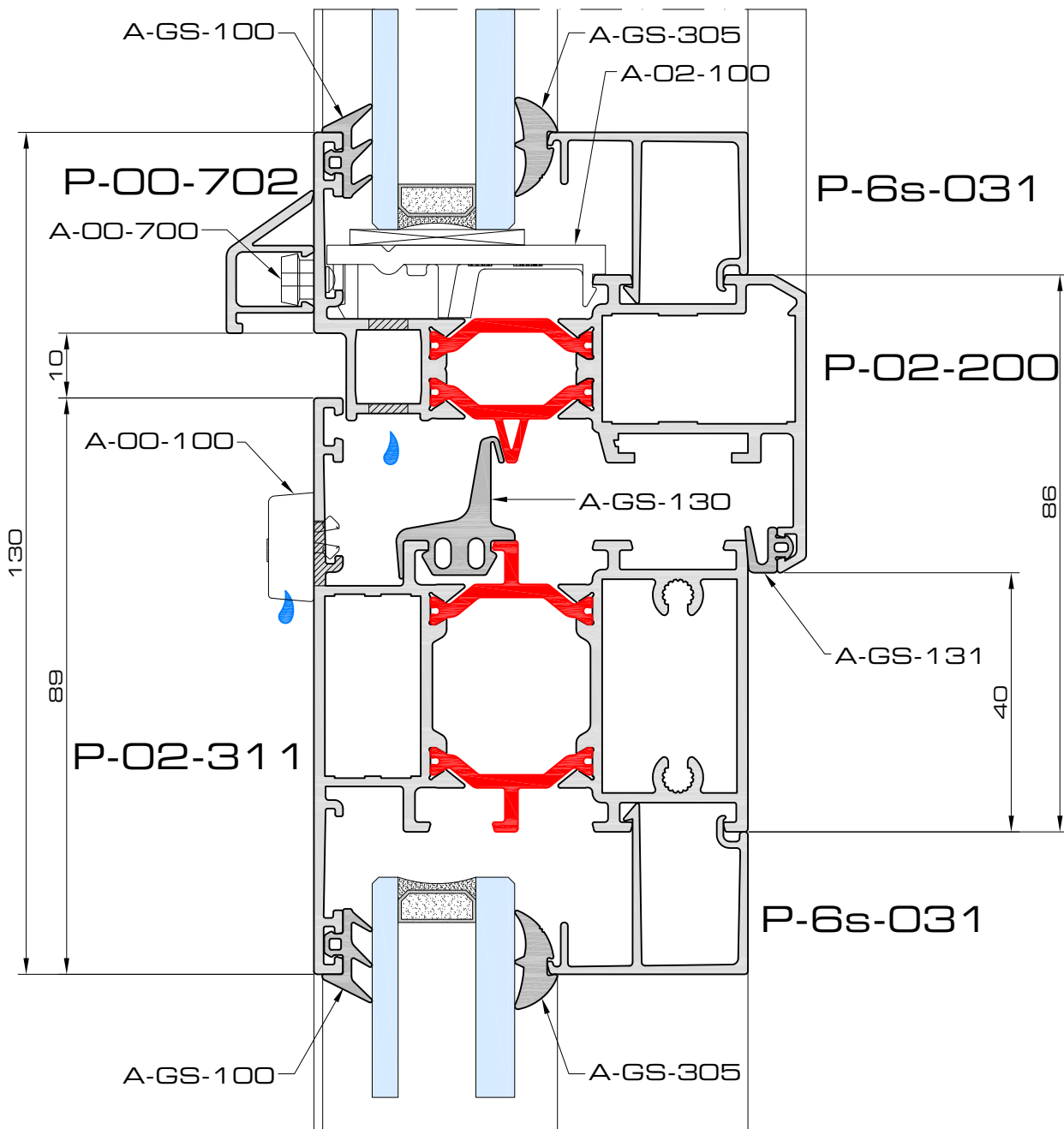
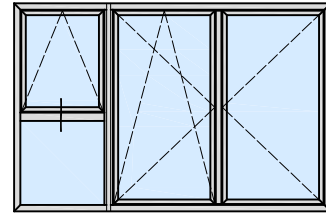

door6b



Variant!
PVC-nut

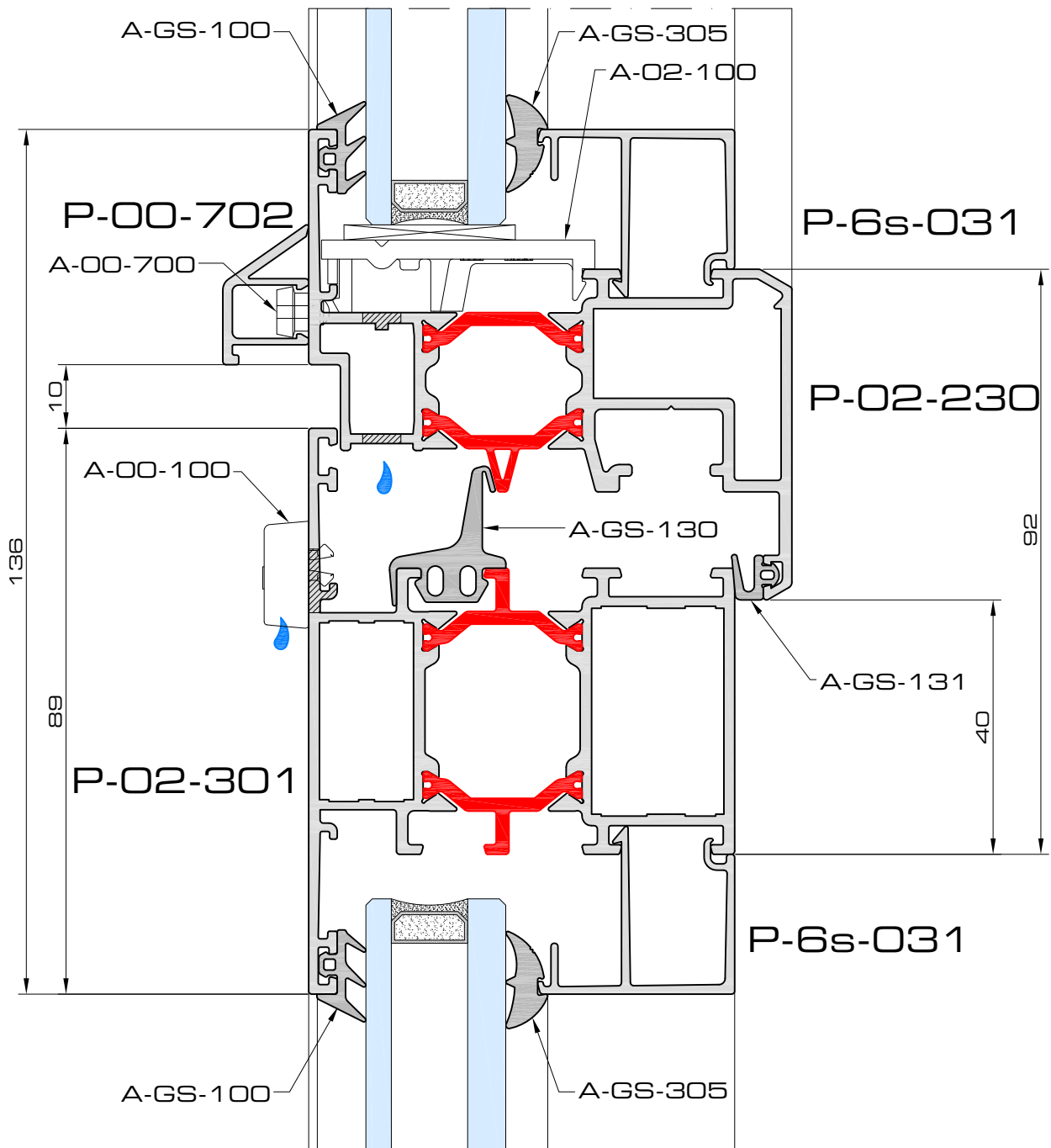
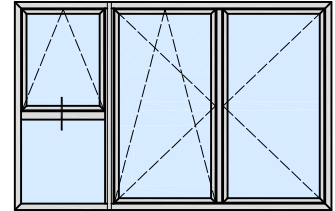

door6c

6.1a

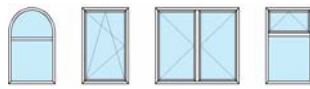

Hercules P02

doorsneden ■ coupes ■ sections

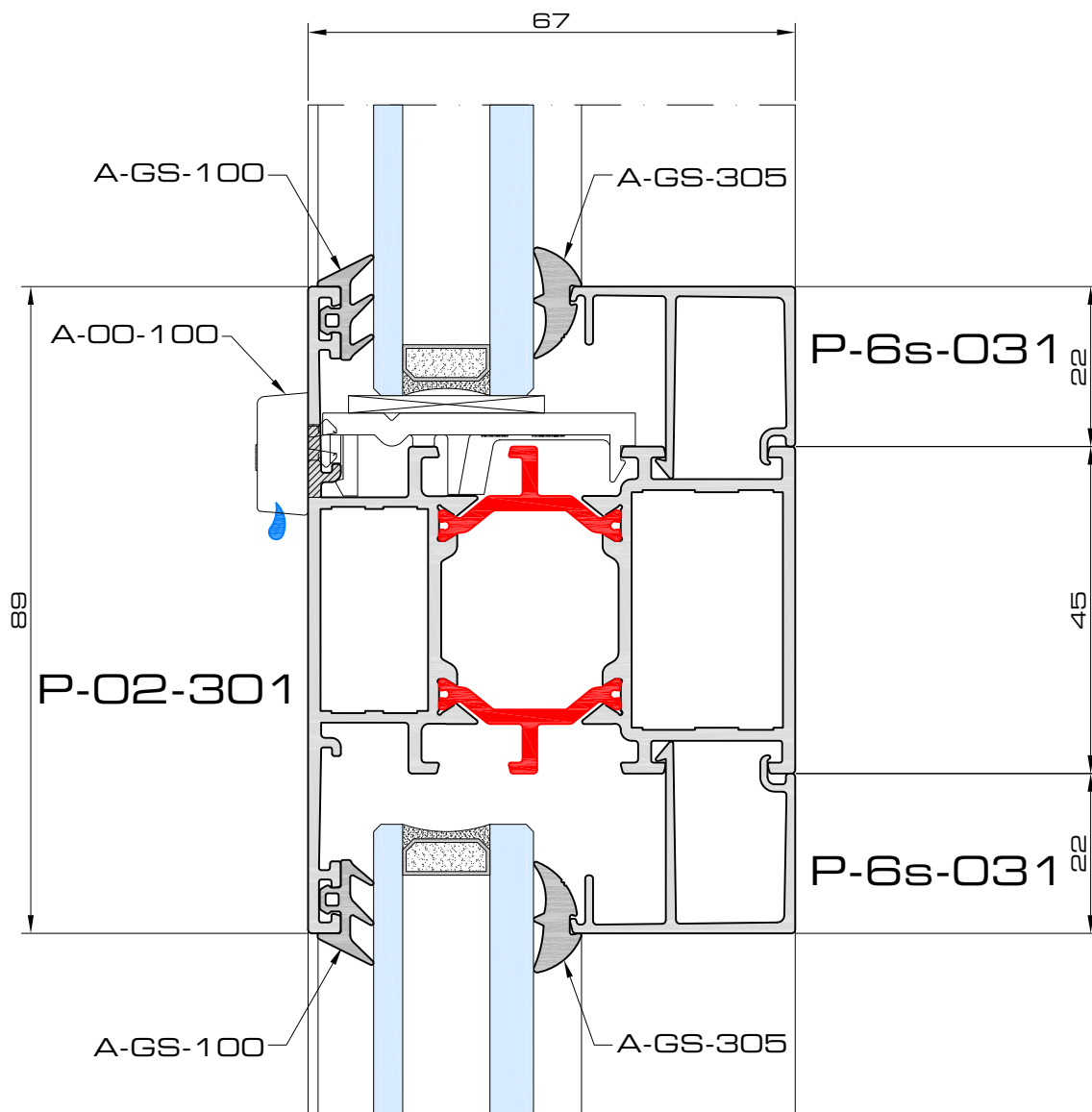
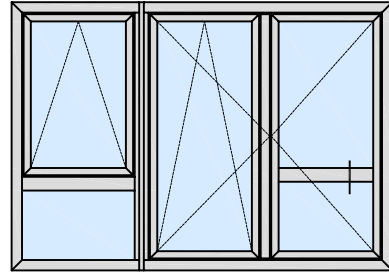

door6-1

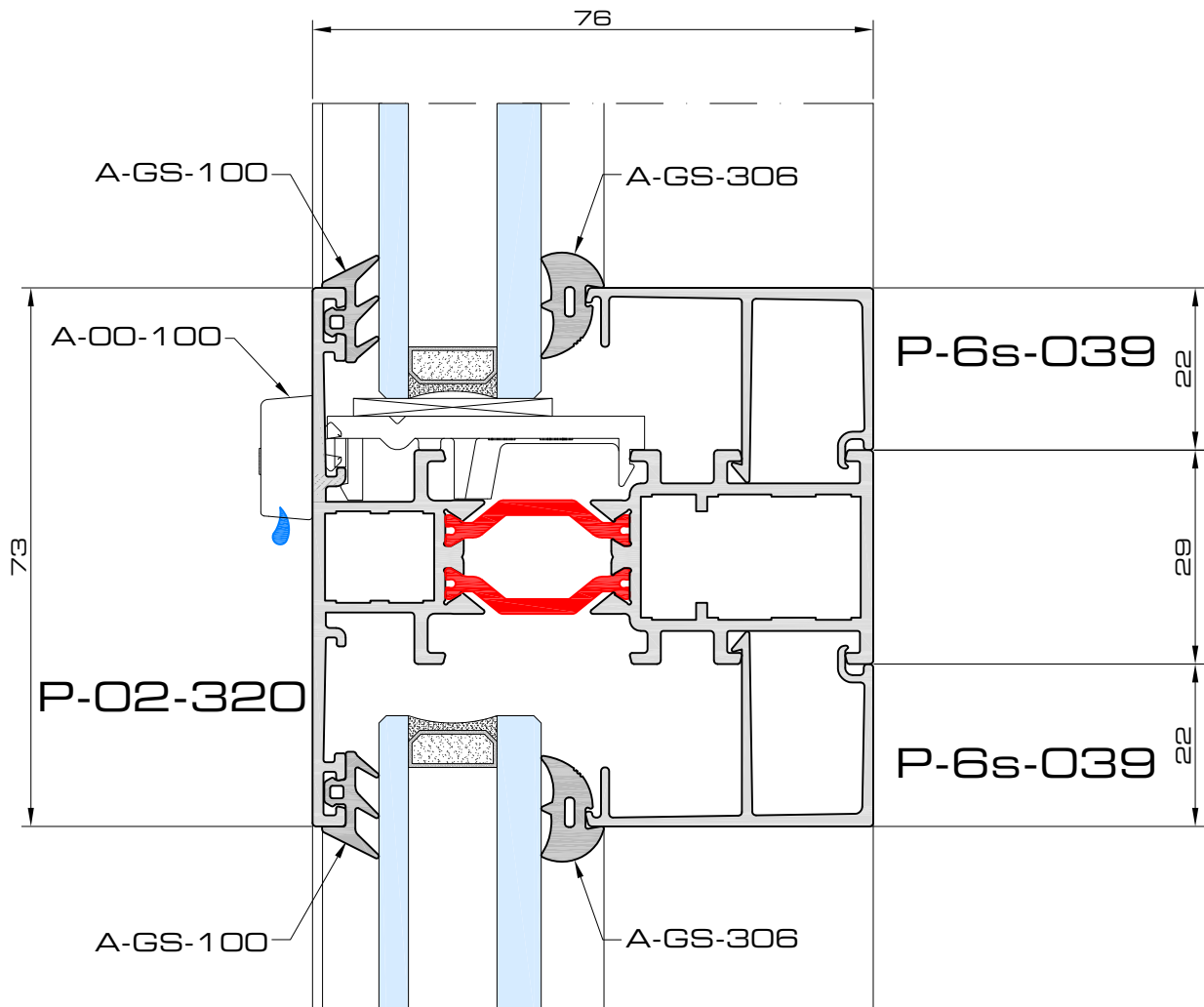
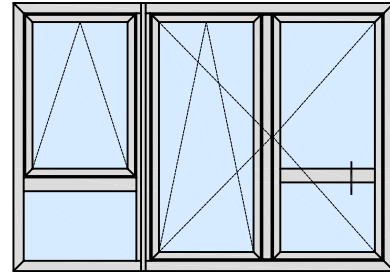
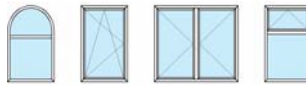

door6-1a

7a

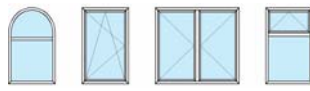

Hercules P02

doorsneden ■ coupes ■ sections

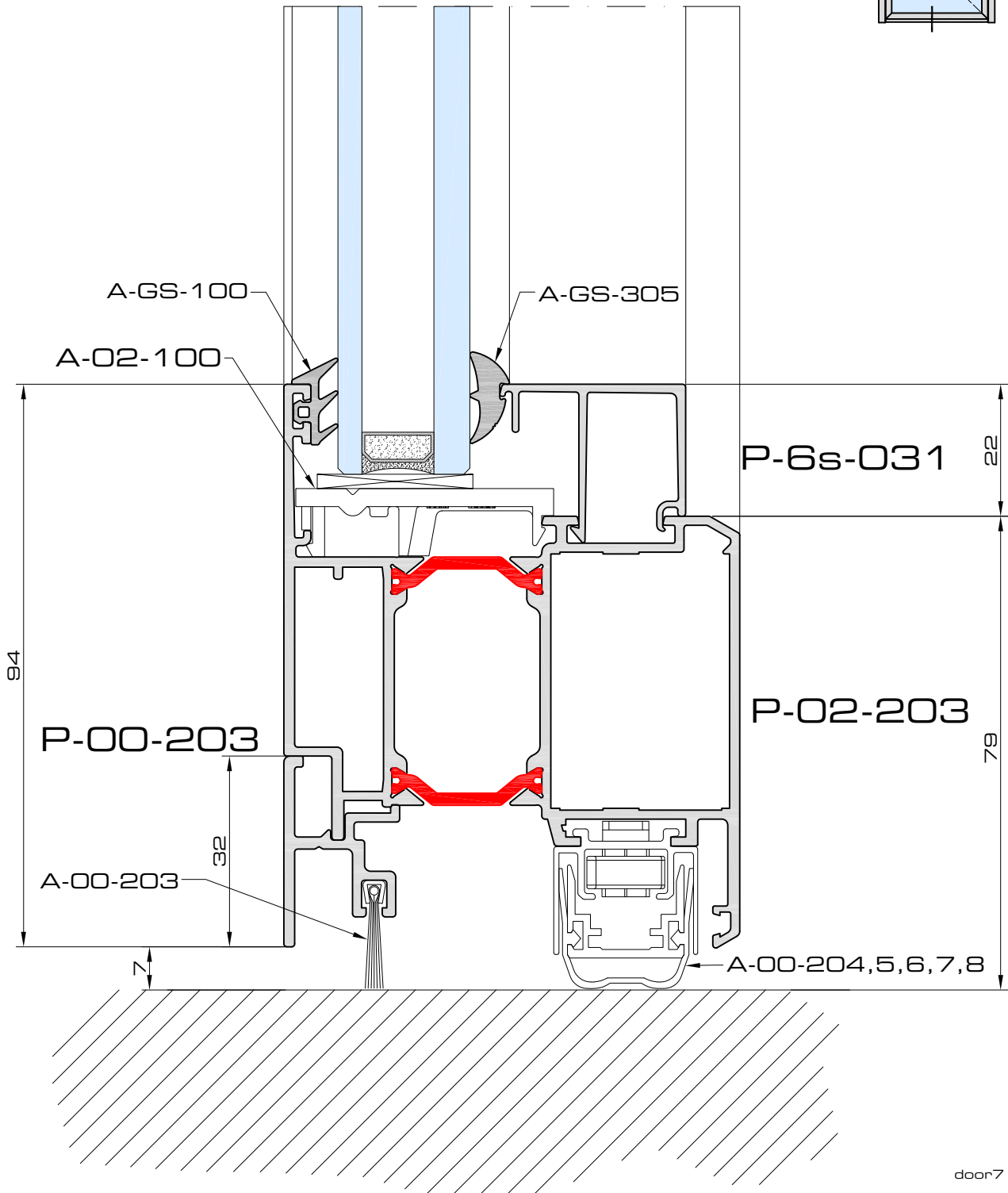
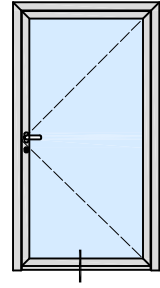

door7

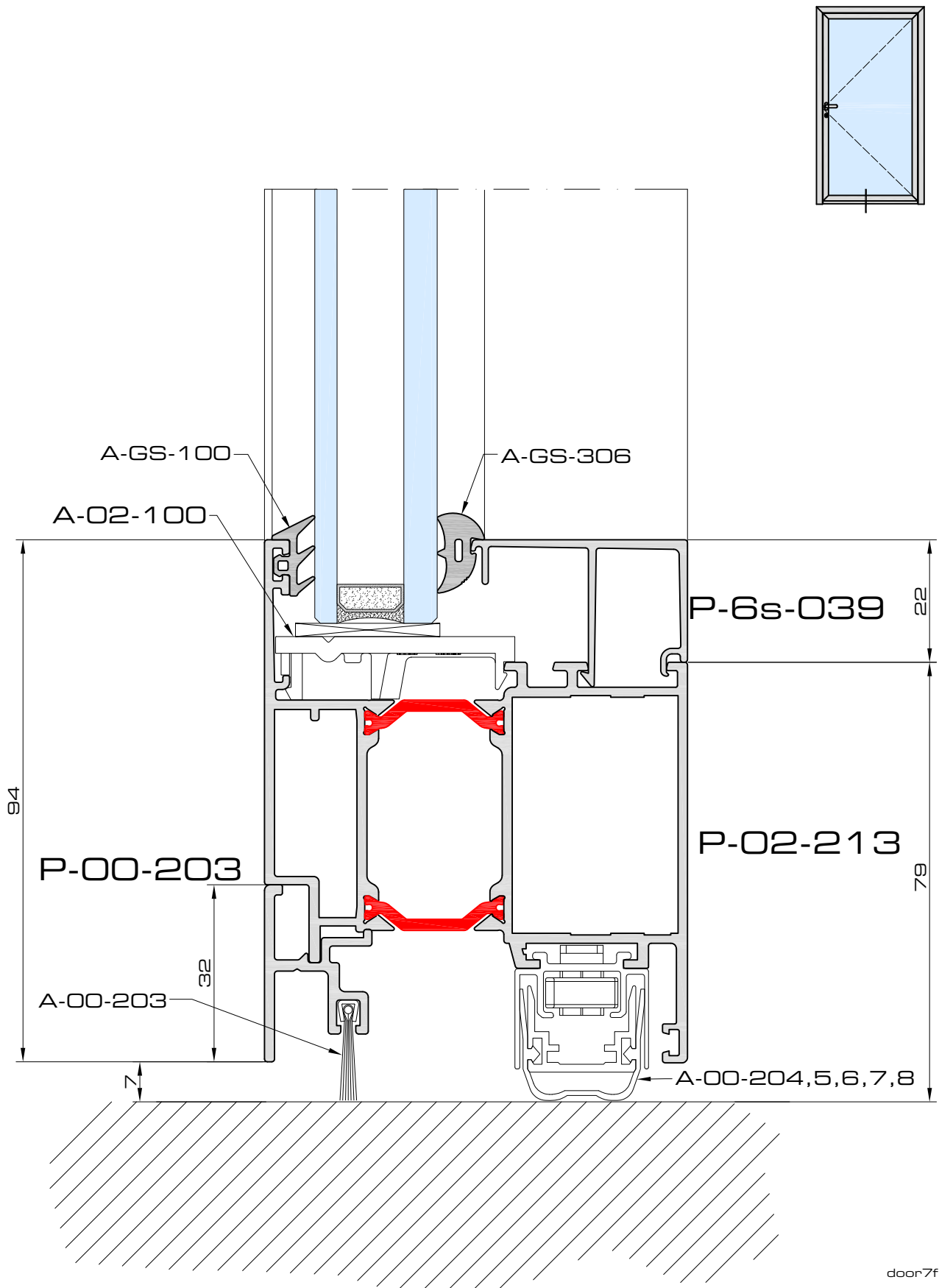
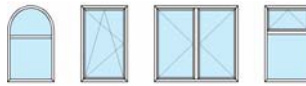

door7f

7c

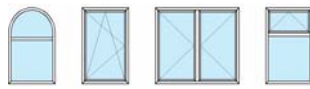

Hercules P02

doorsneden ■ coupes ■ sections

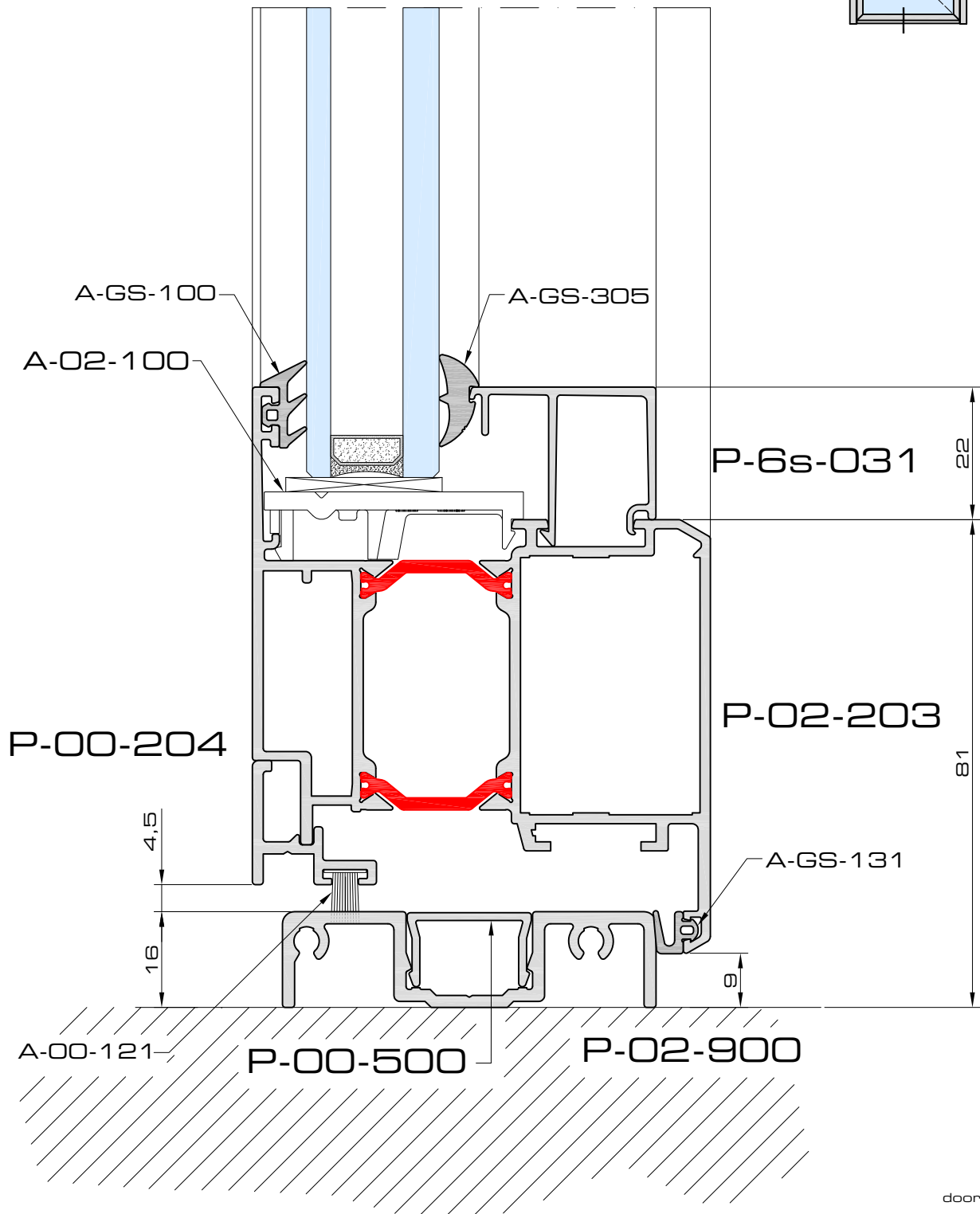
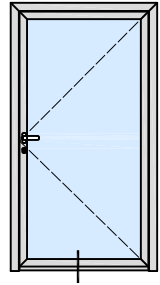

door7b

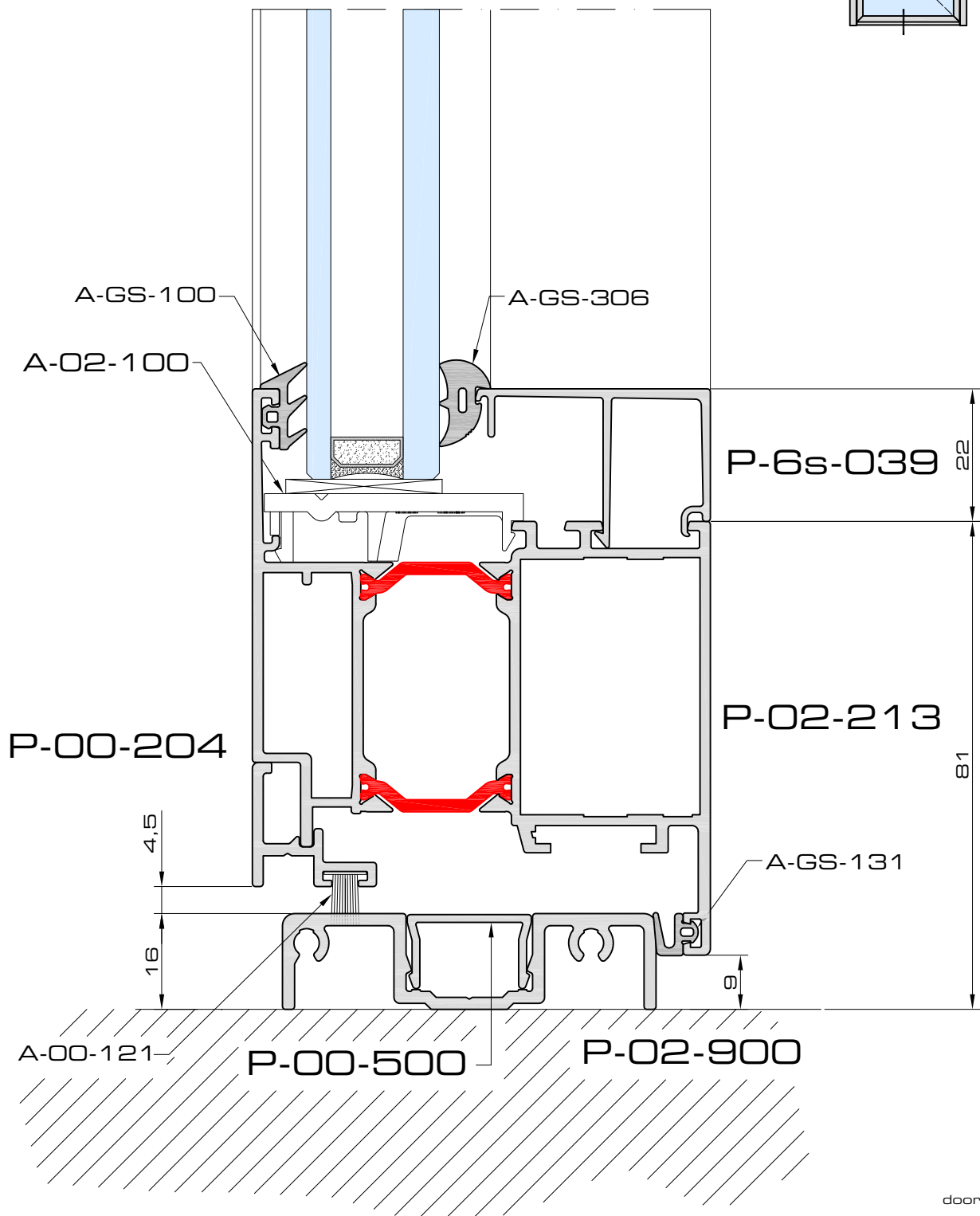
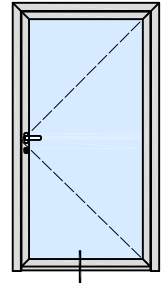

door7g

7e

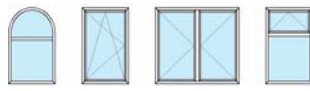

Hercules P02

doorsneden ■ coupes ■ sections

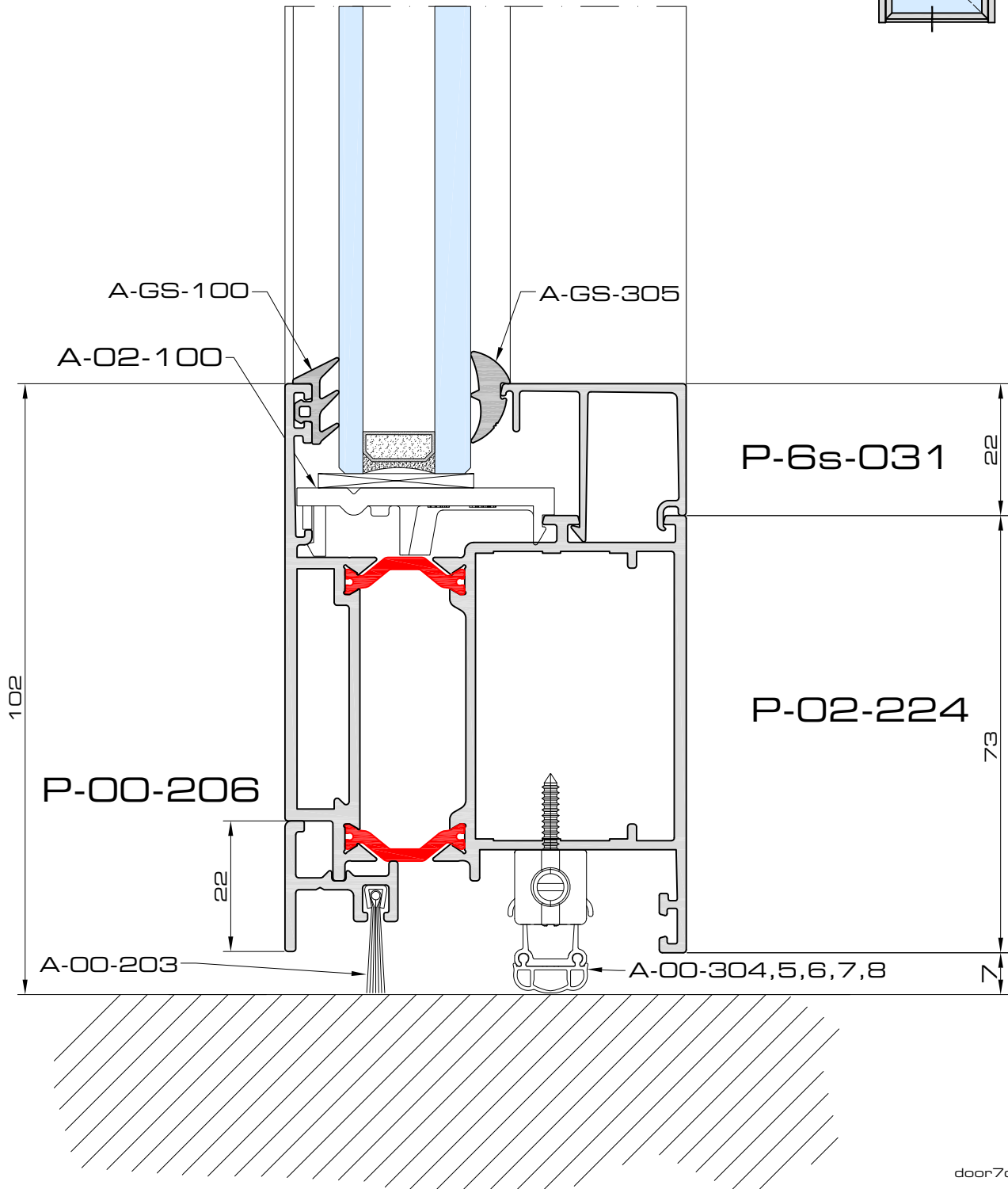
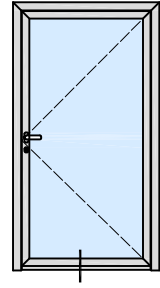

door7c

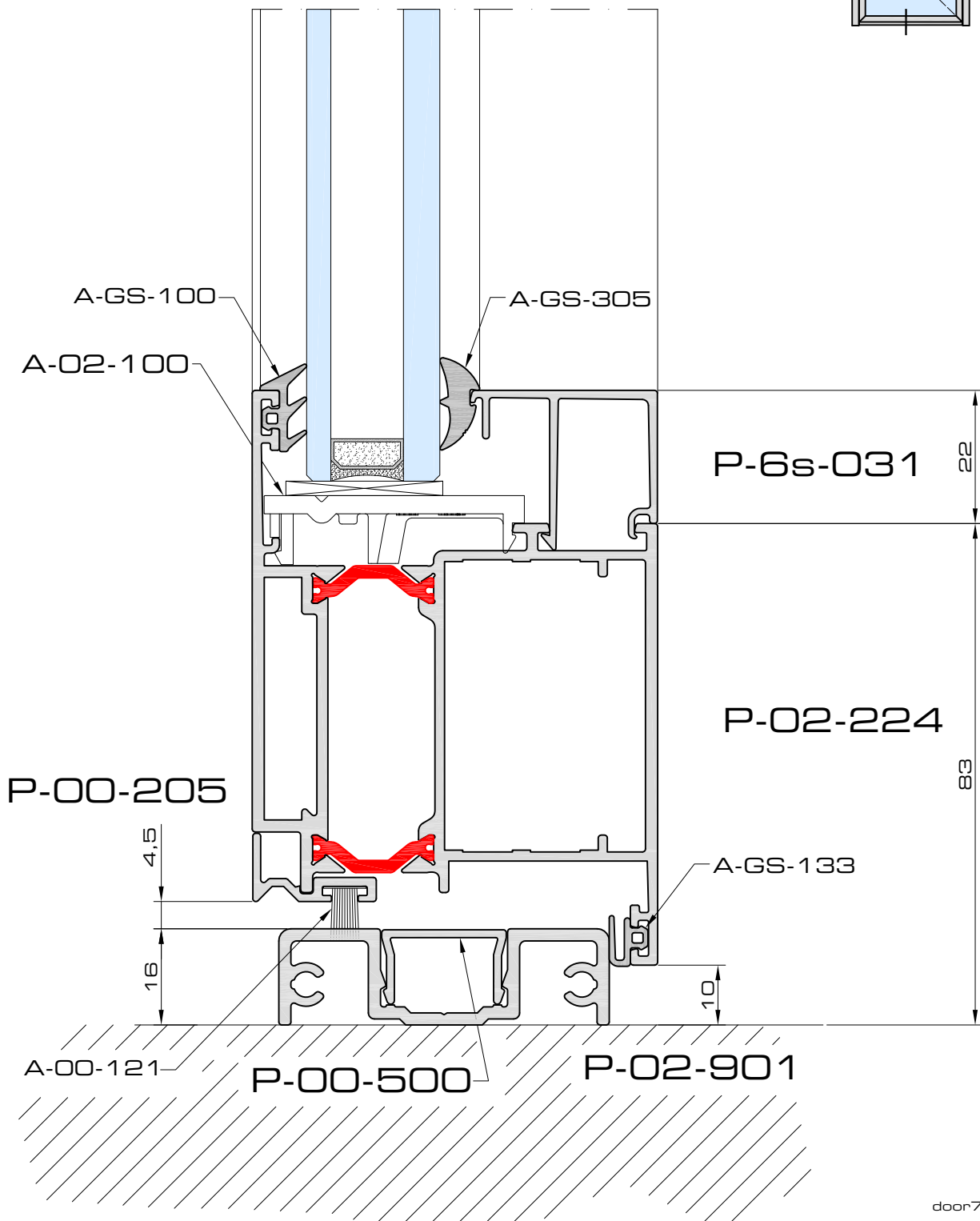
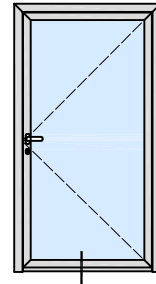
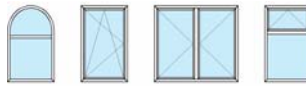

door7d

7g

doorsneden ■ coupes ■ sections

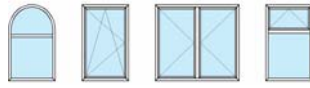

Hercules P02

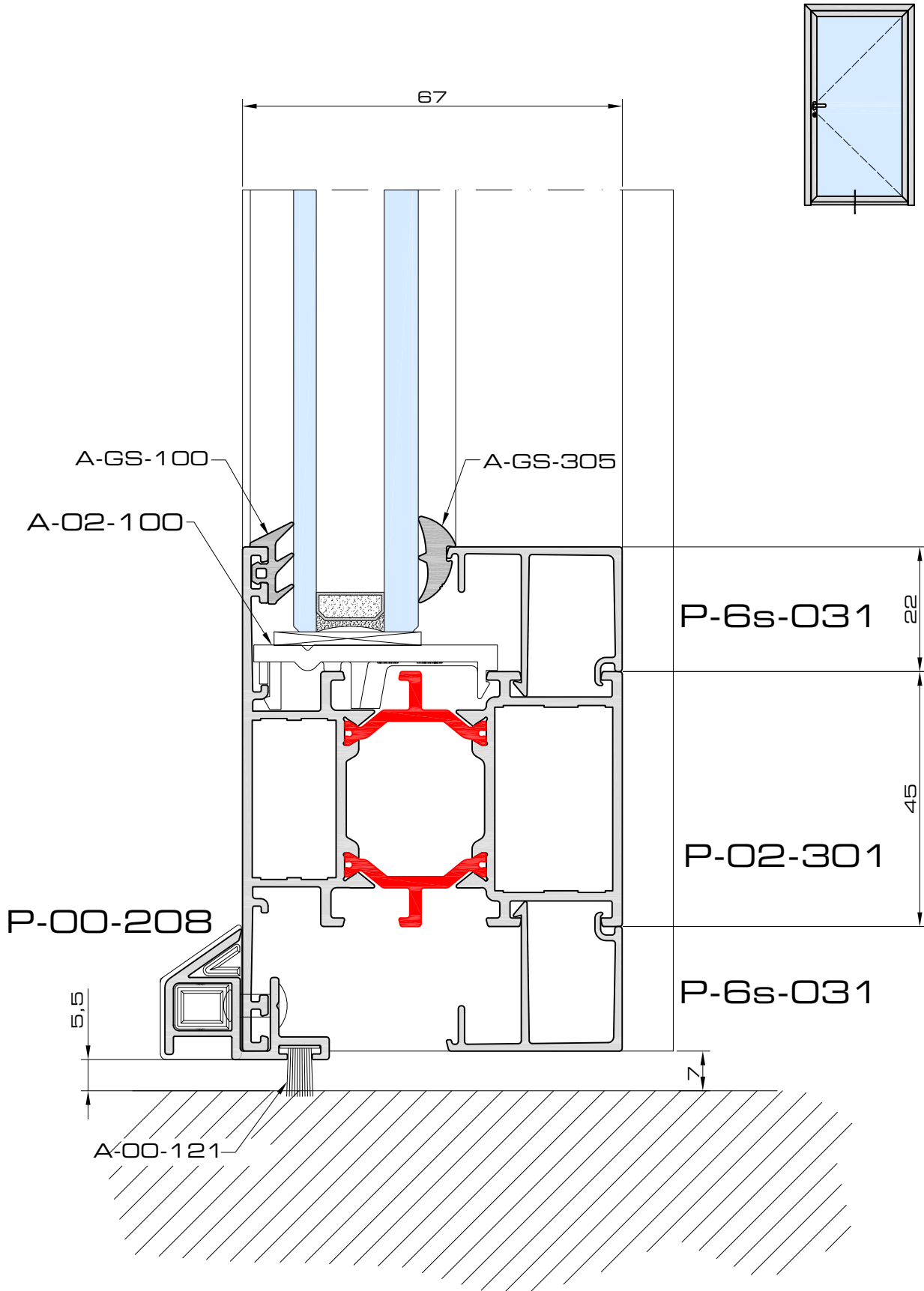

door7e

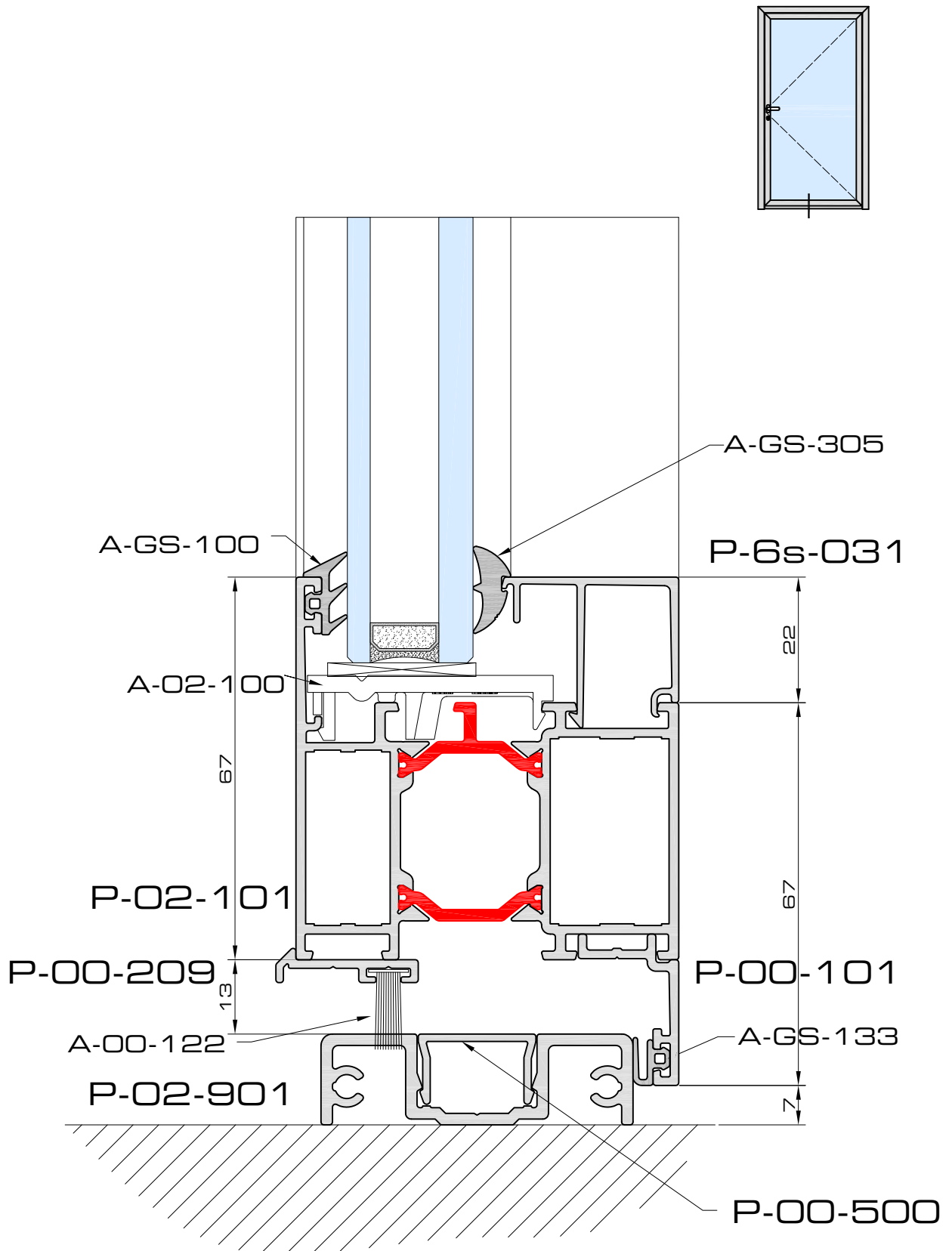

door7h

8a

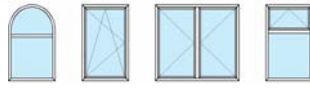

Hercules P02

doorsneden ■ coupes ■ sections

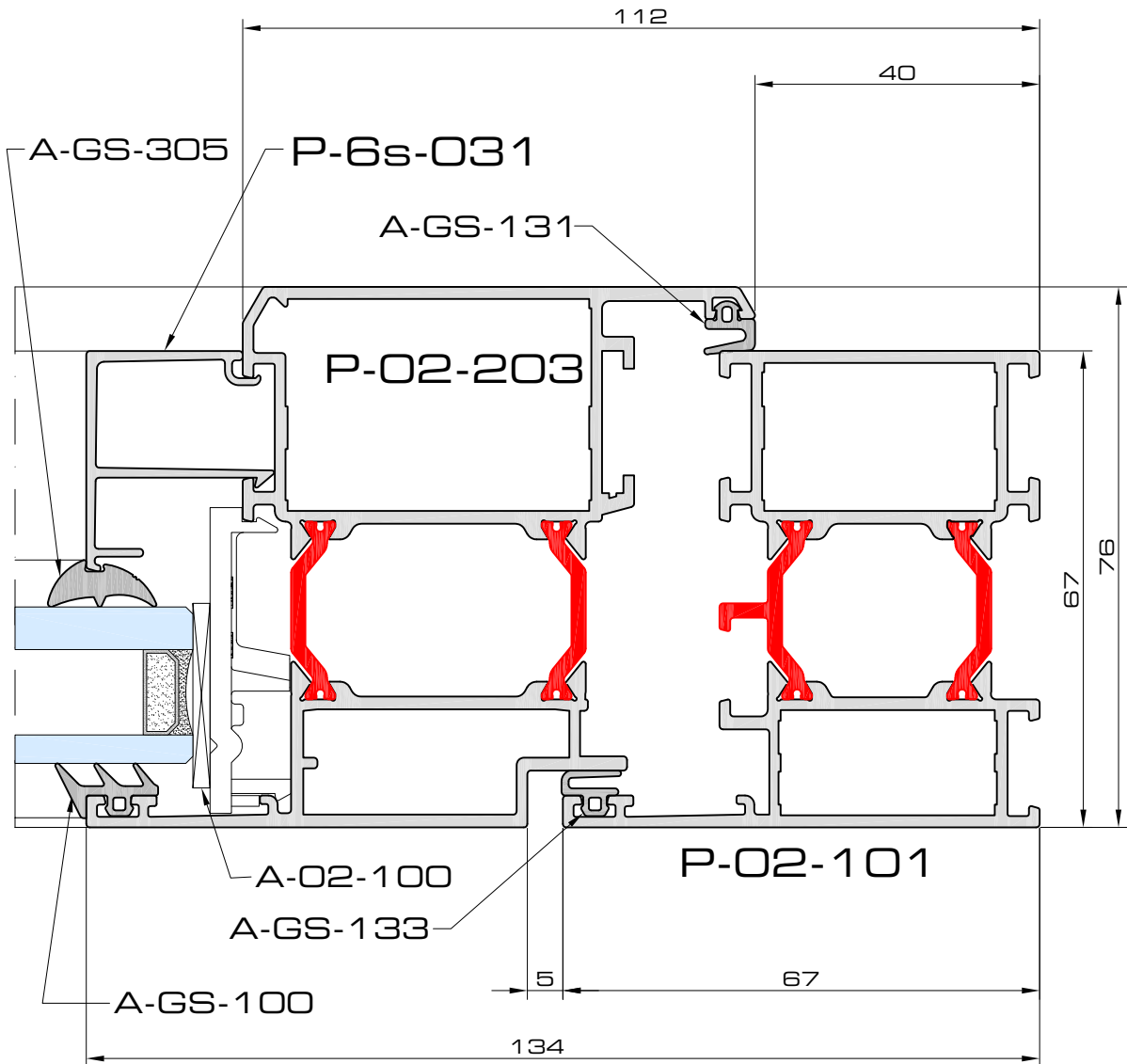
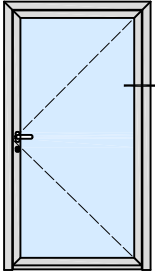

door8

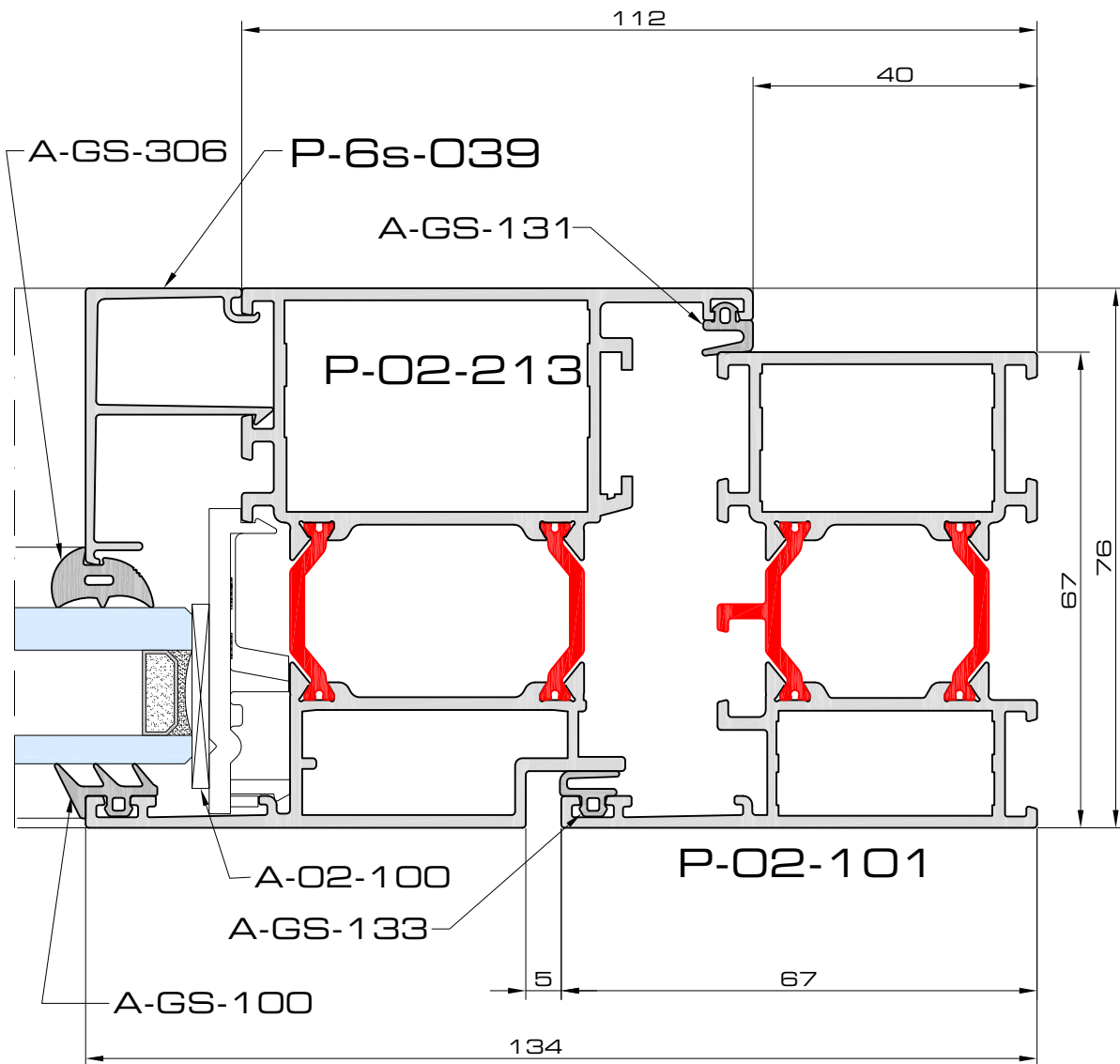
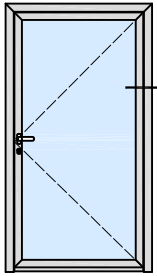

door8d

8c

doorsneden ■ coupes ■ sections

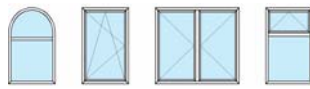

Hercules P02

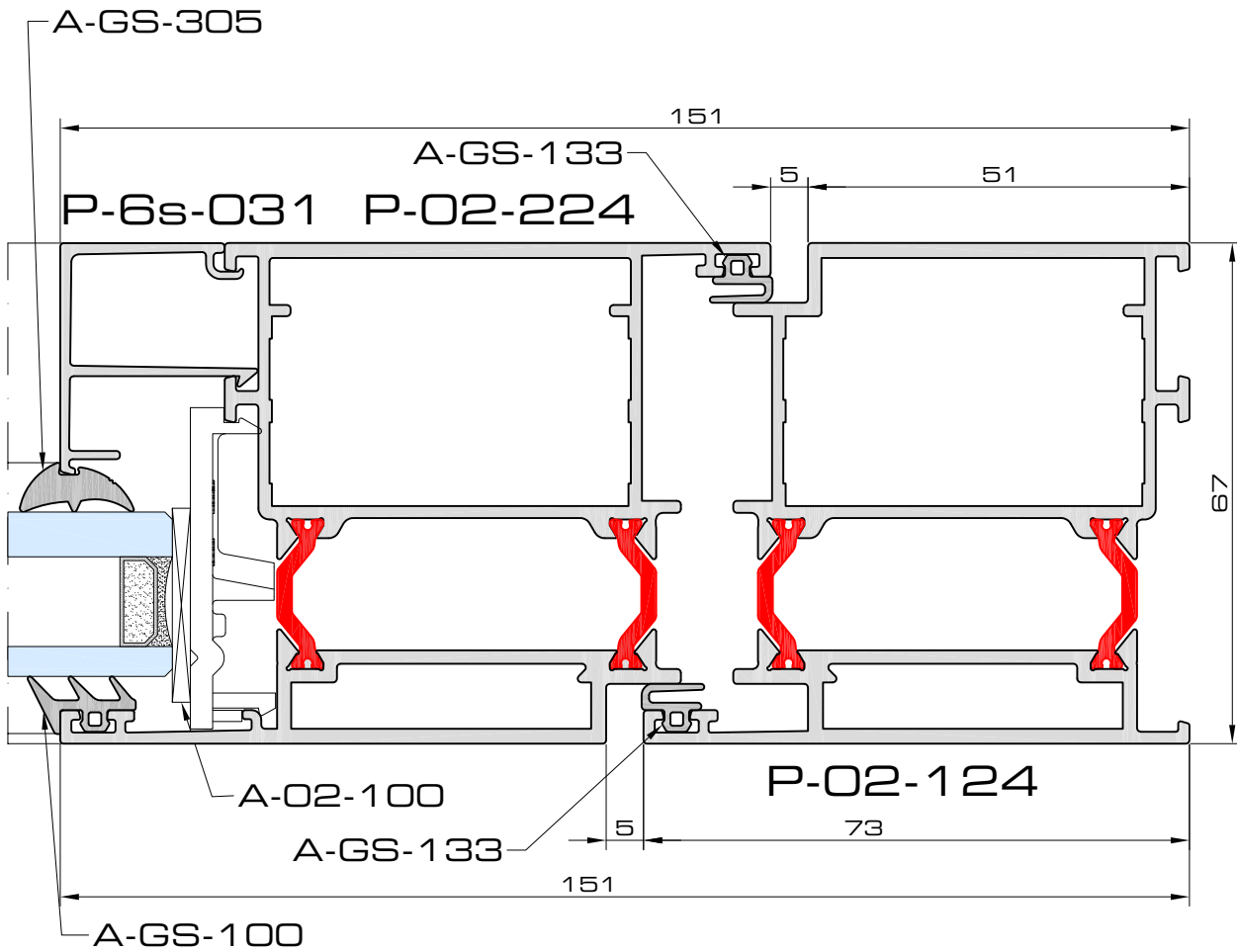
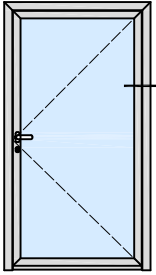

door8b

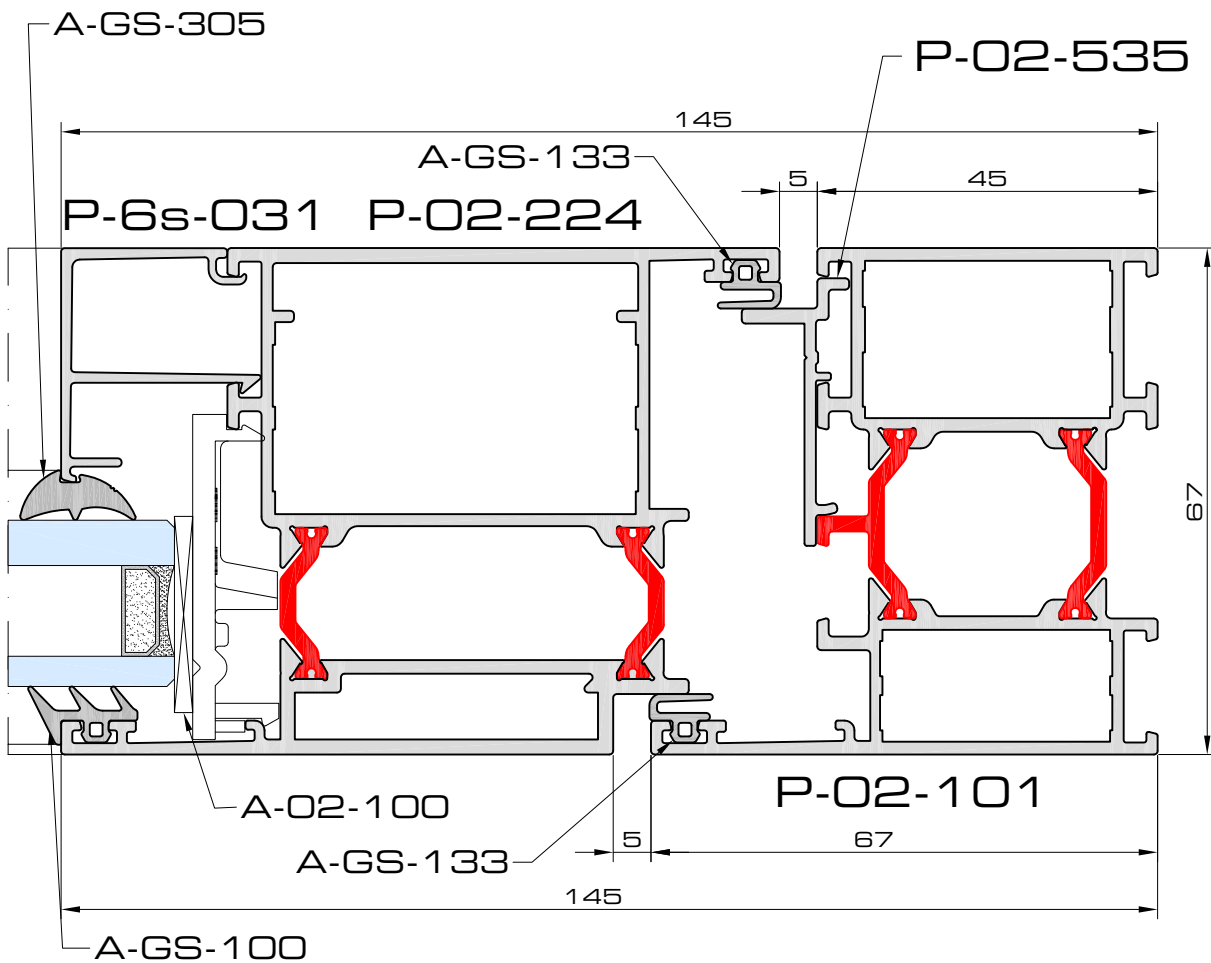
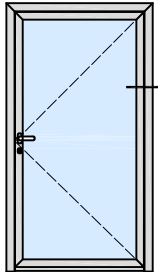

door8c

9a



Hercules P02

doorsneden ■ coupes ■ sections

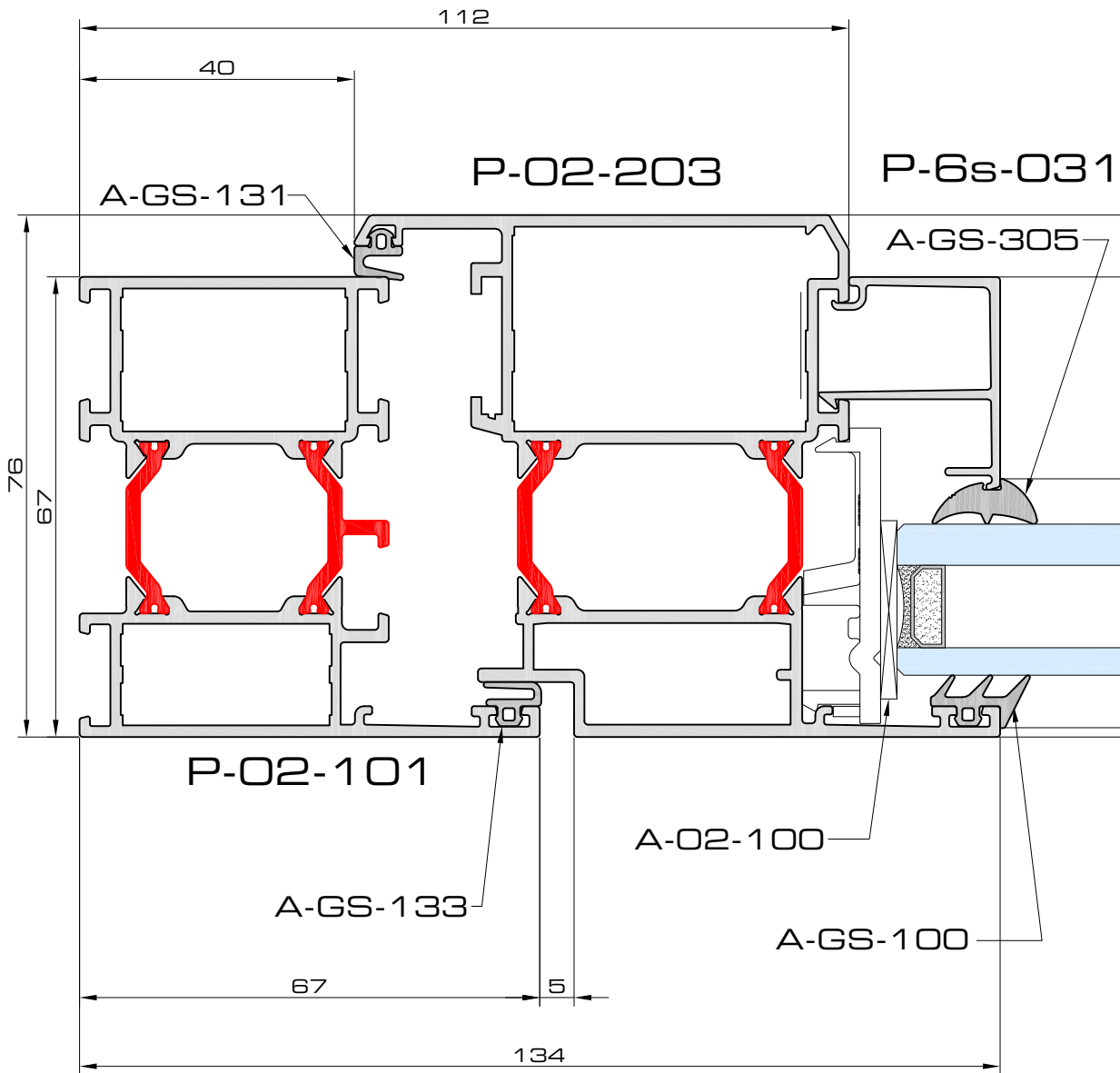
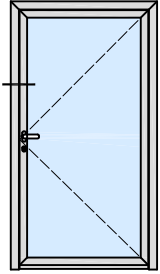

door9

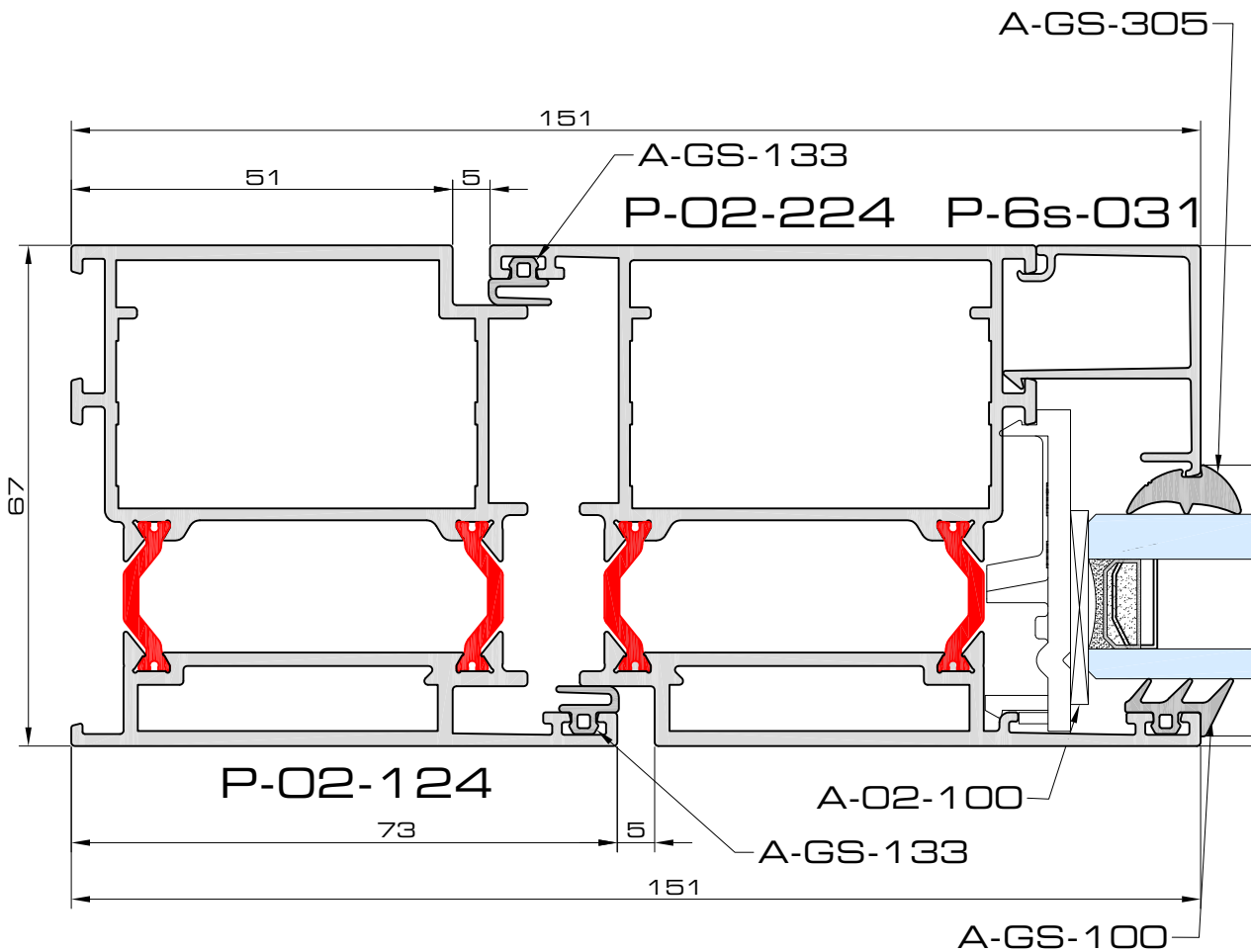
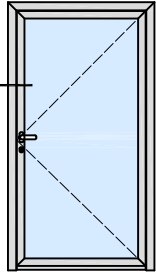
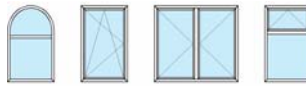

door9b

9c

doorsneden ■ coupes ■ sections

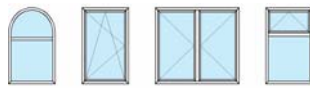

Hercules P02

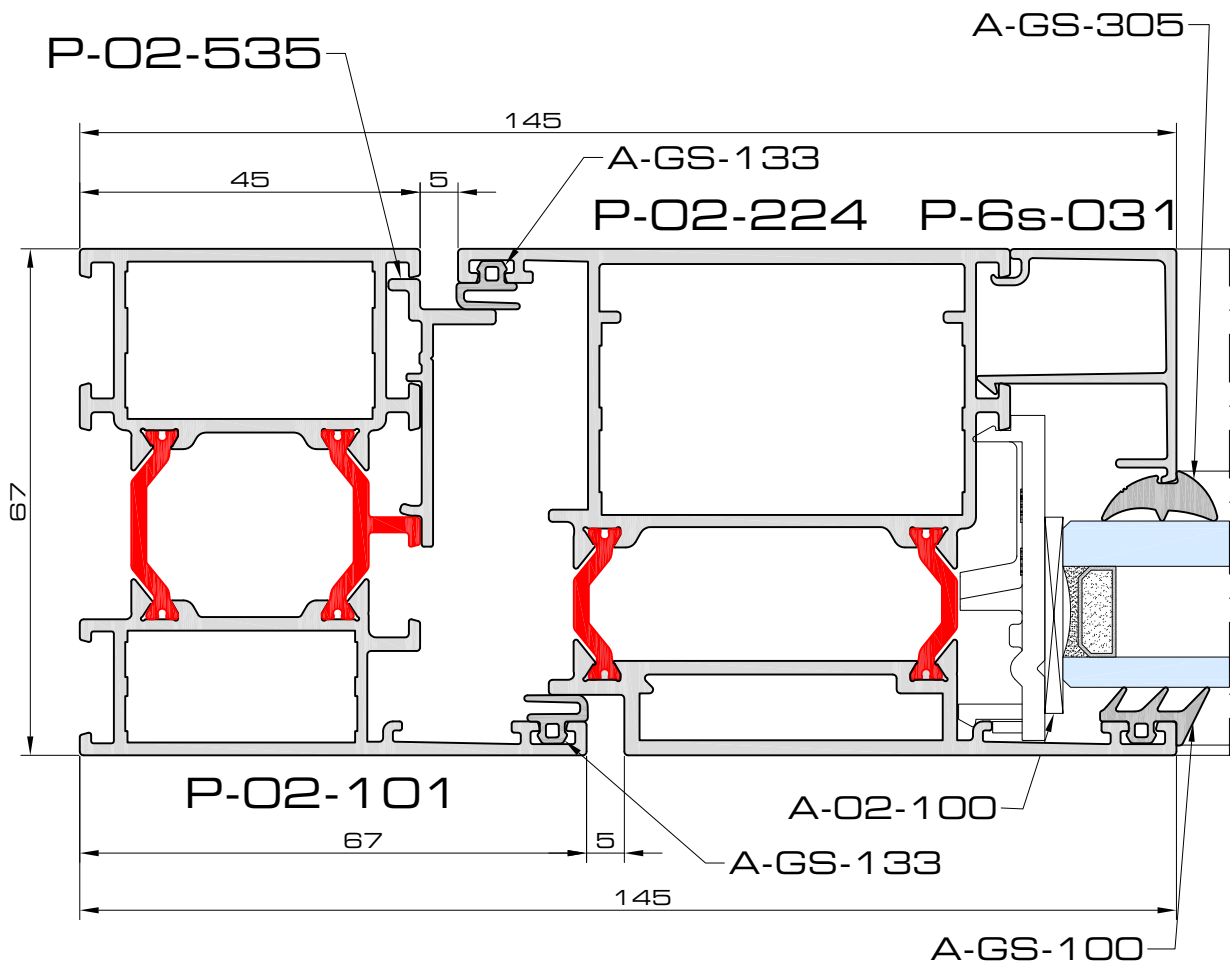
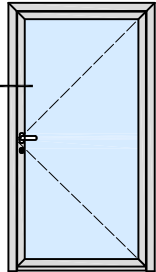

door9c

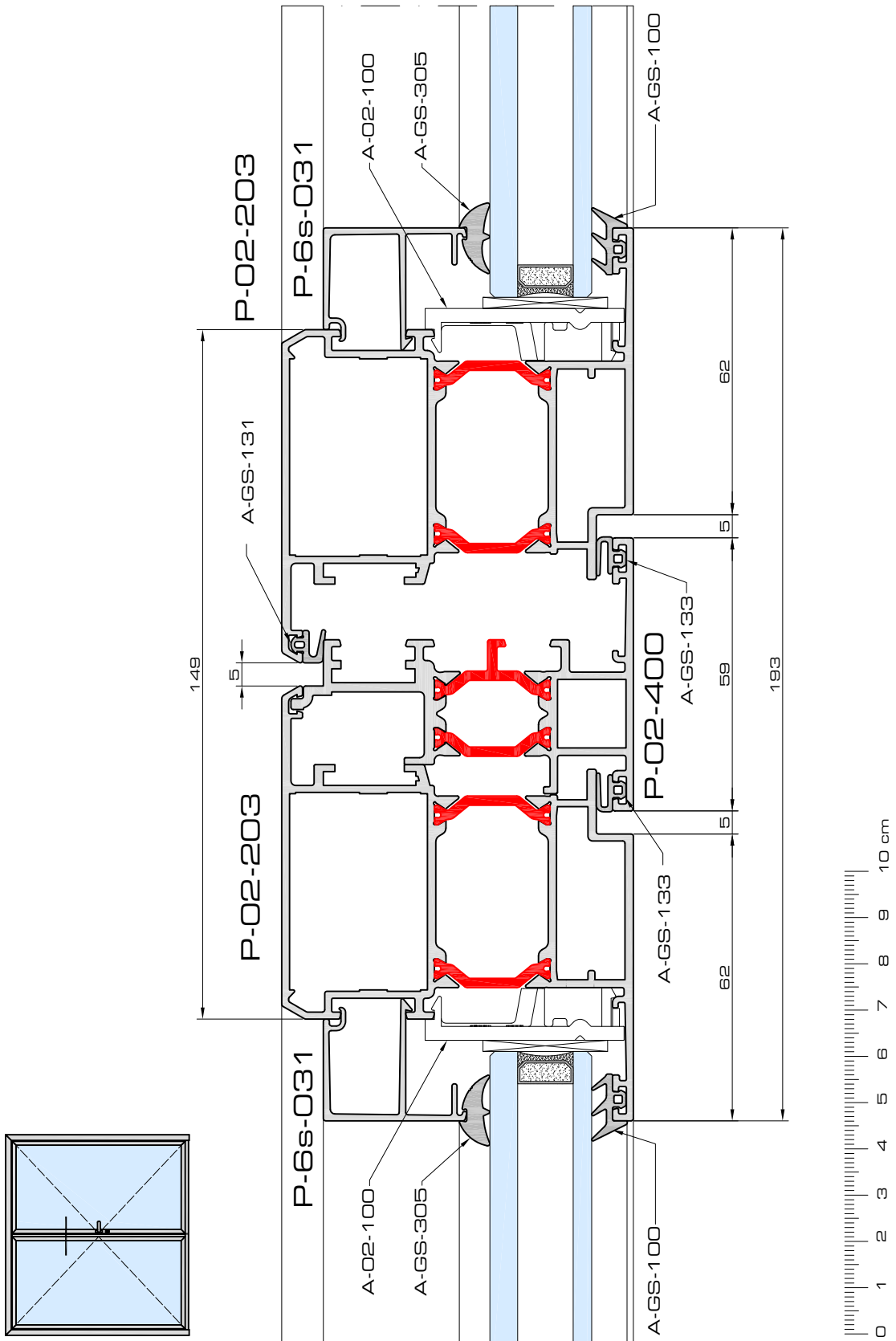
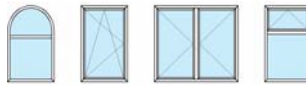

door10

10b

doorsneden ■ coupes ■ sections

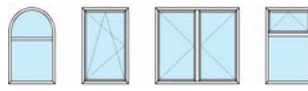

Hercules P02

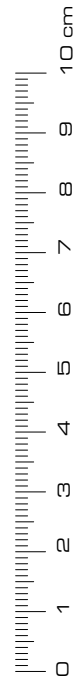
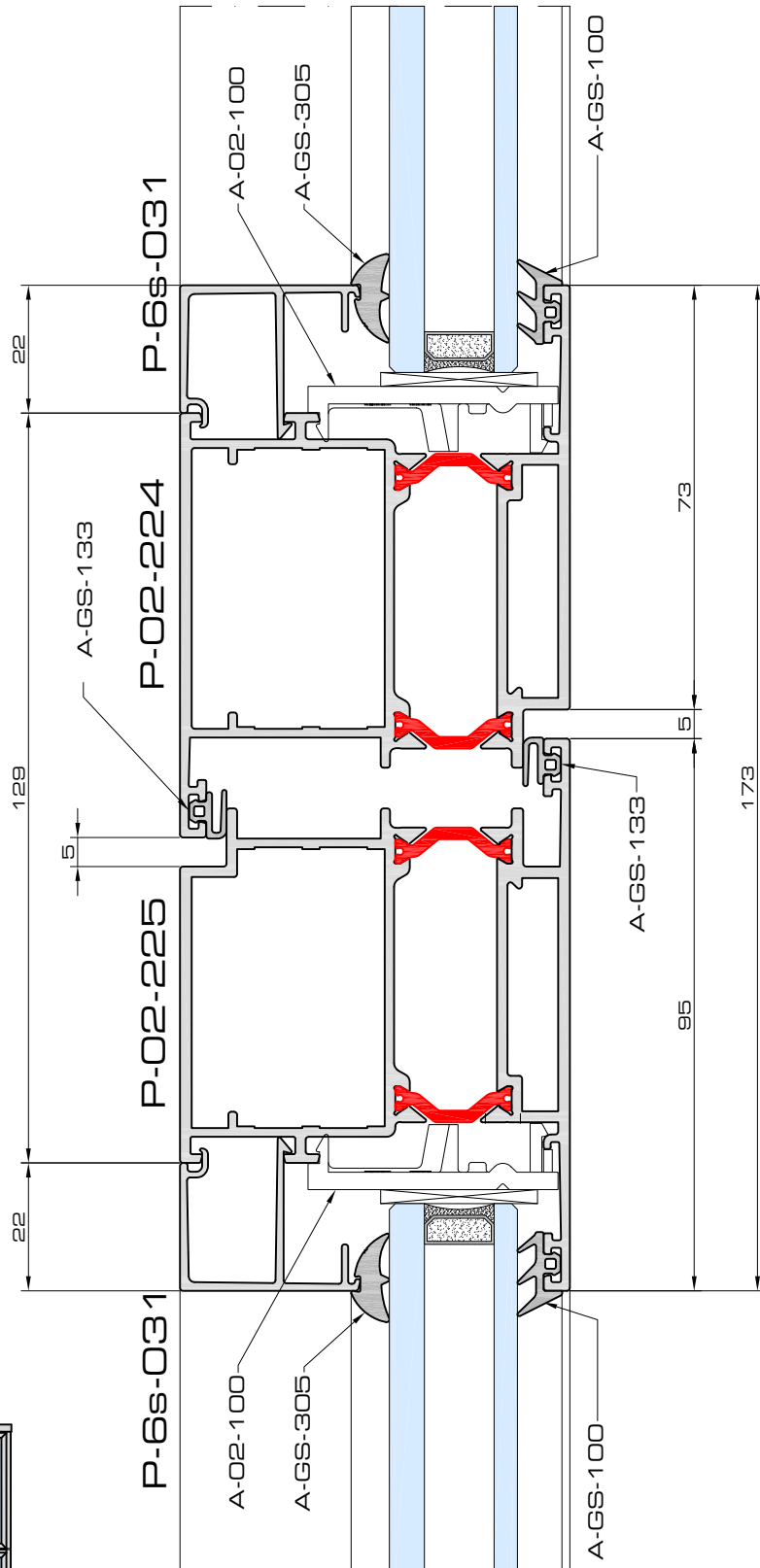
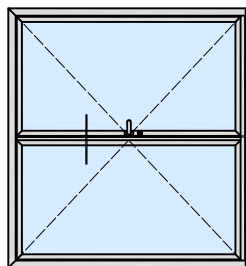

door10b

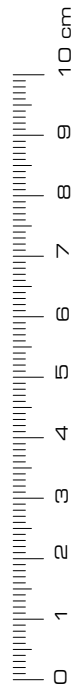
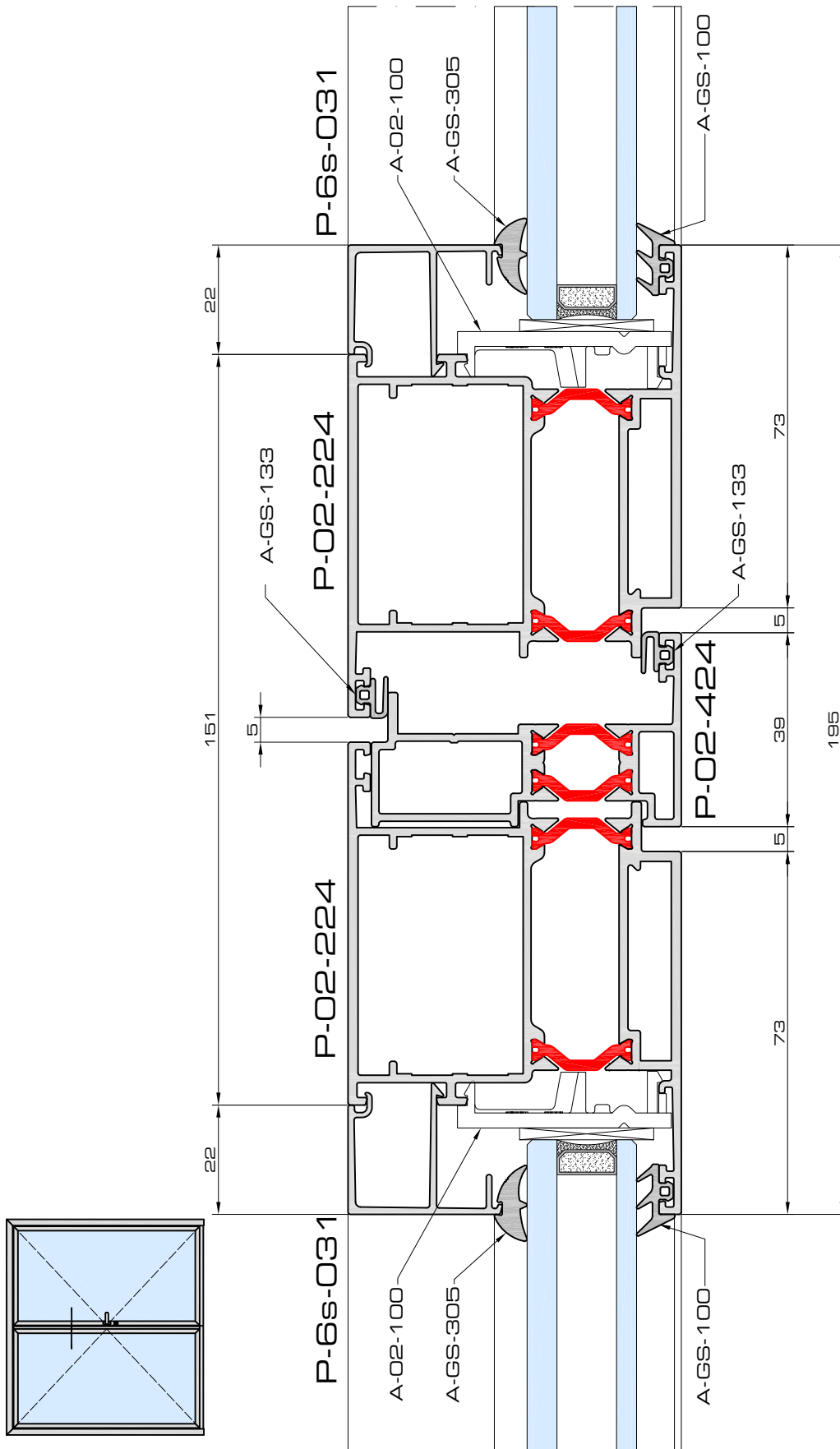
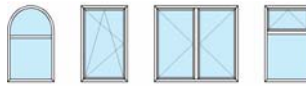

door10c

11a

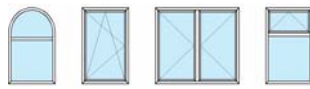

doorsneden ■ coupes ■ sections

Hercules P02

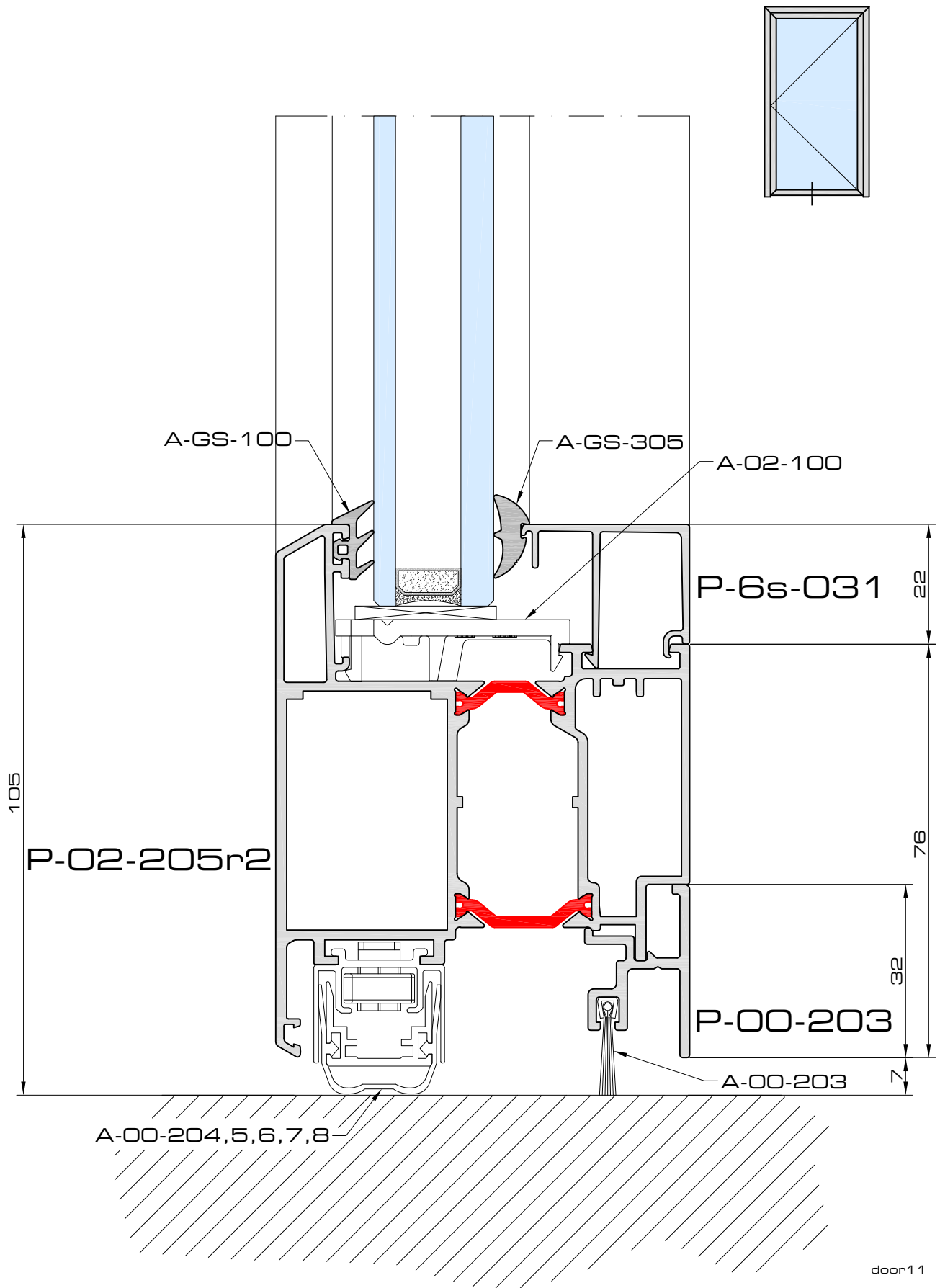

door11

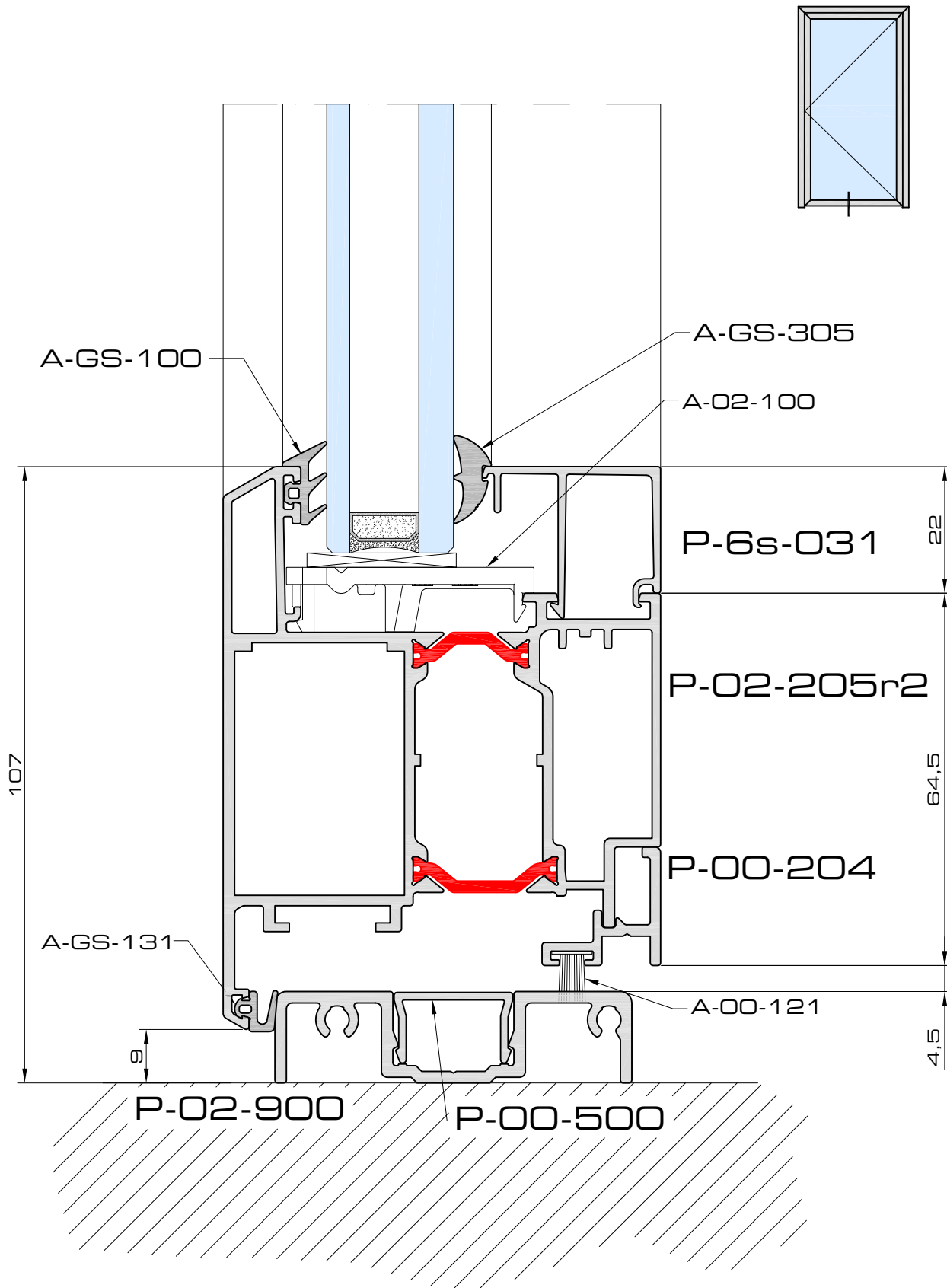

door11b

11e

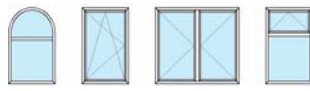

doorsneden ■ coupes ■ sections

HerCules P02

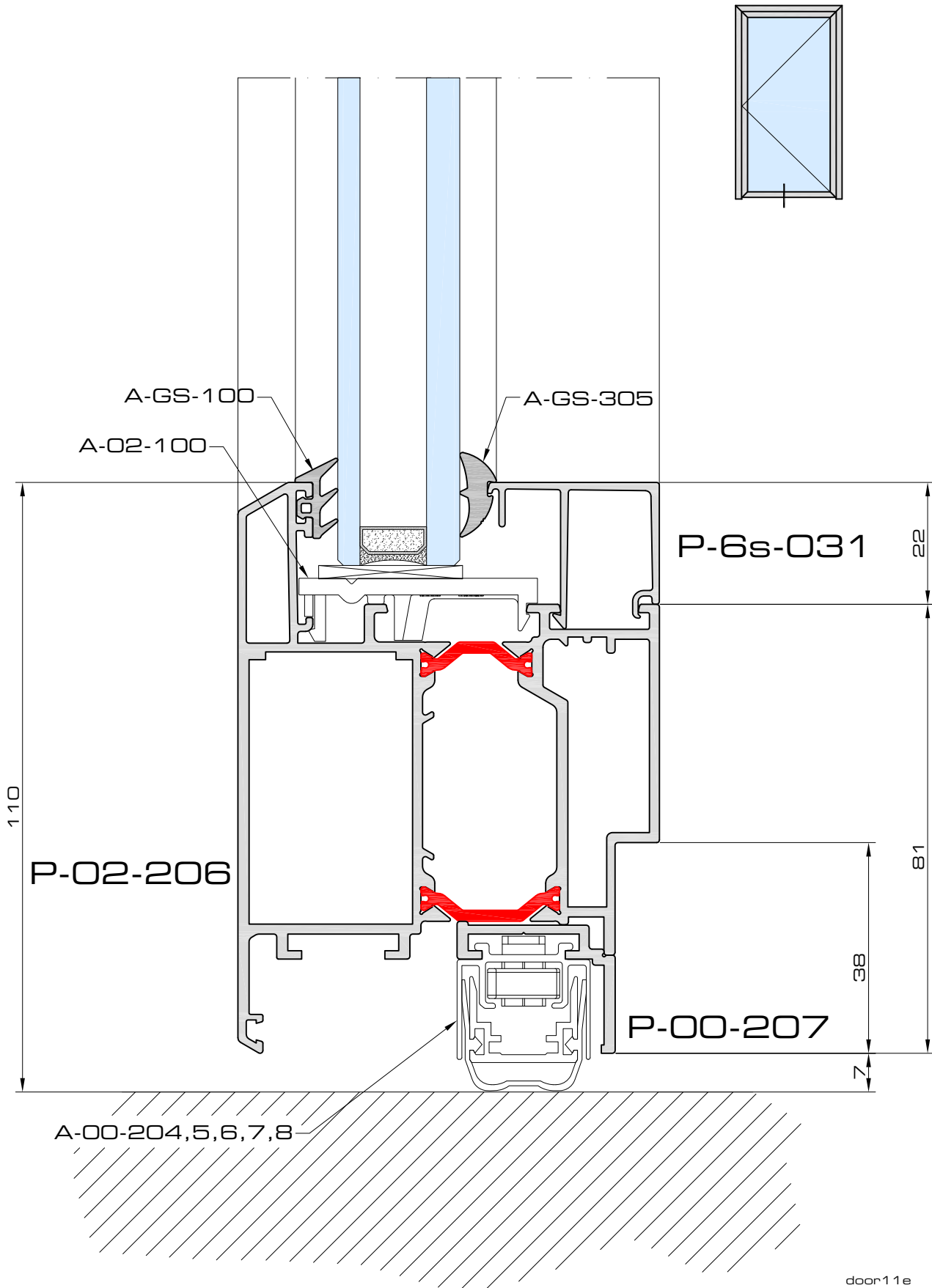

door11e

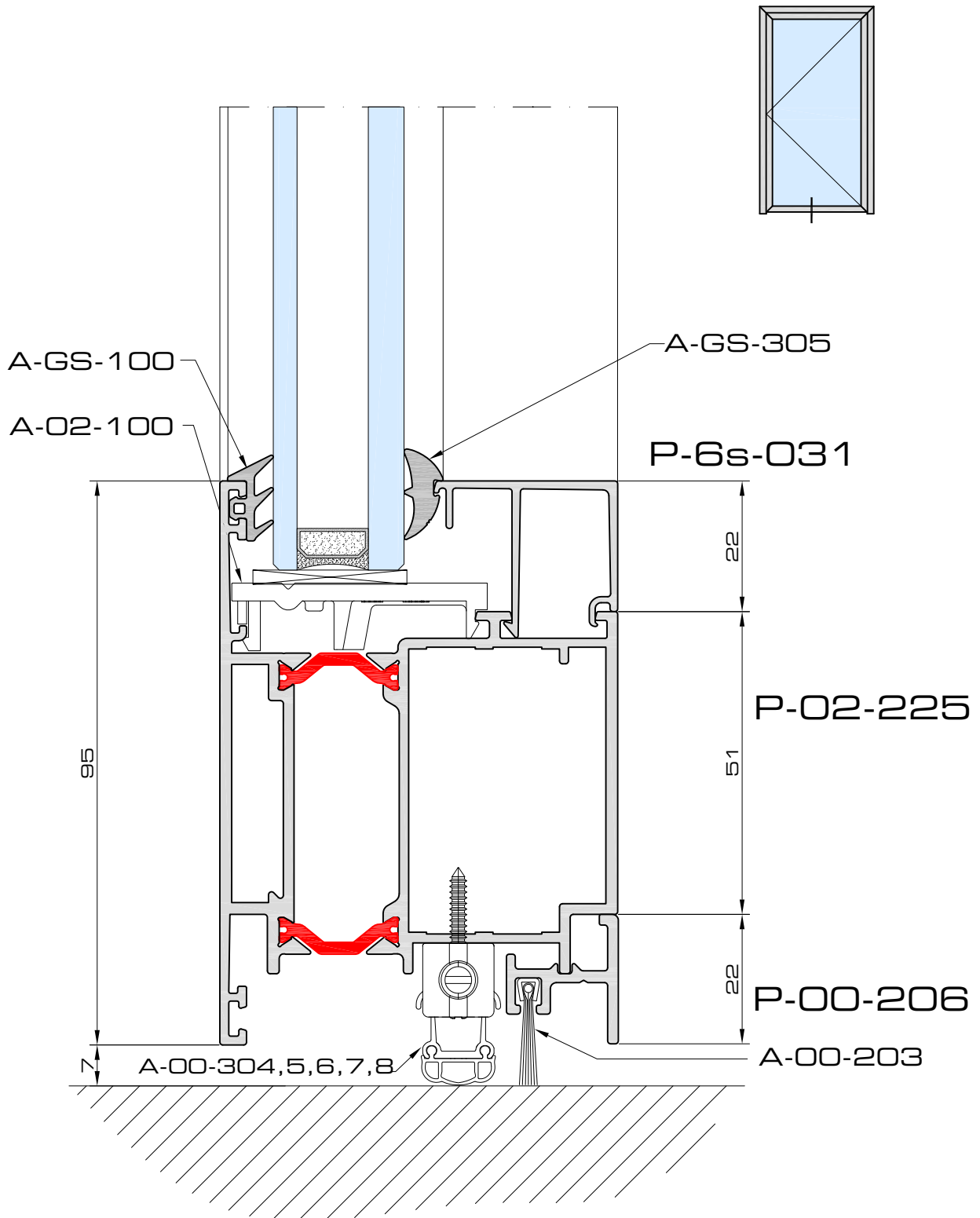
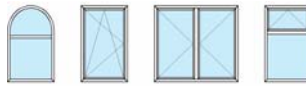

door11c

11d

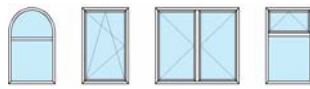

doorsneden ■ coupes ■ sections

Hercules P02

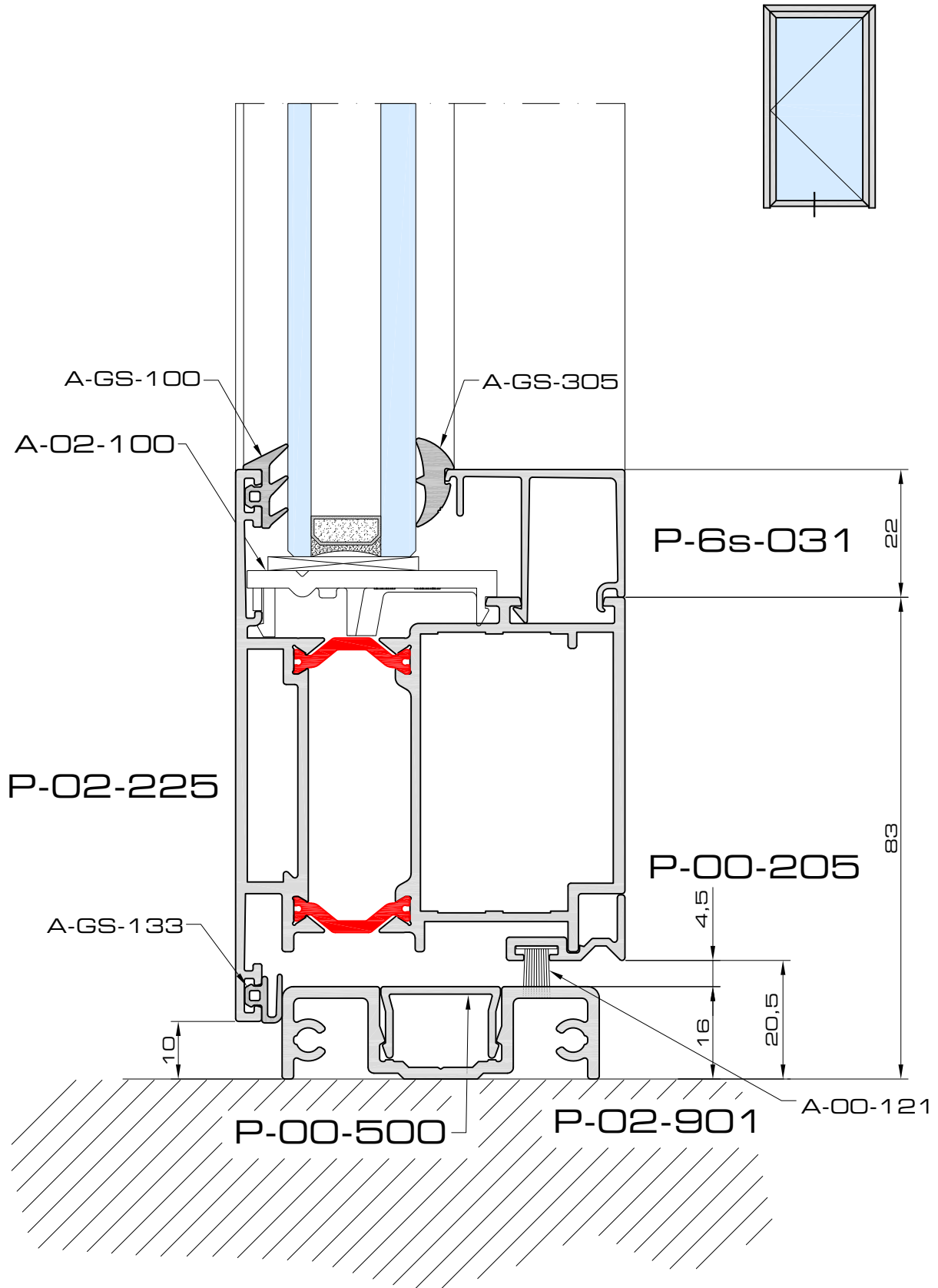

door11d

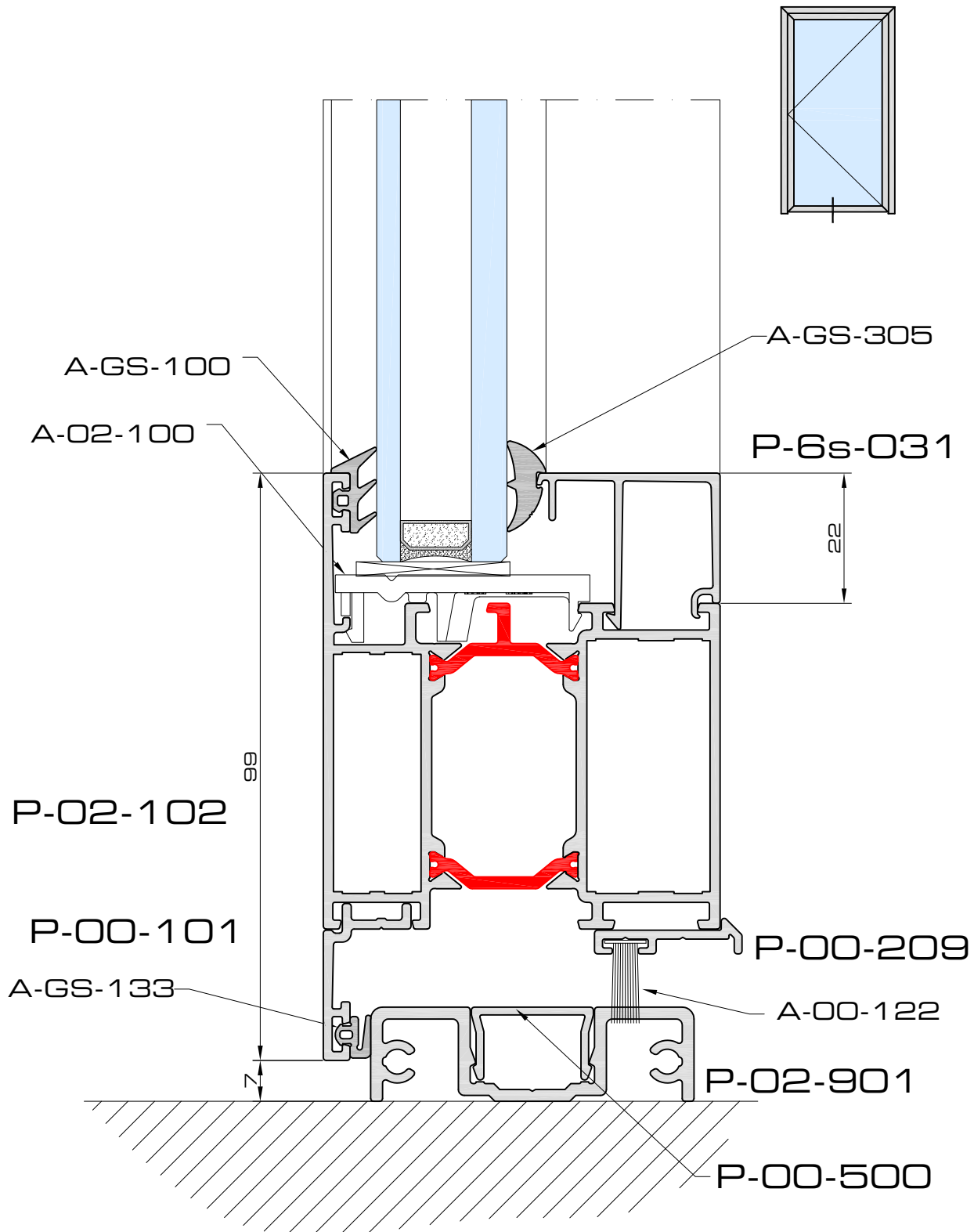

door11f

12a

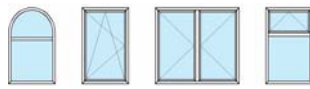

Hercules P02

doorsneden ■ coupes ■ sections

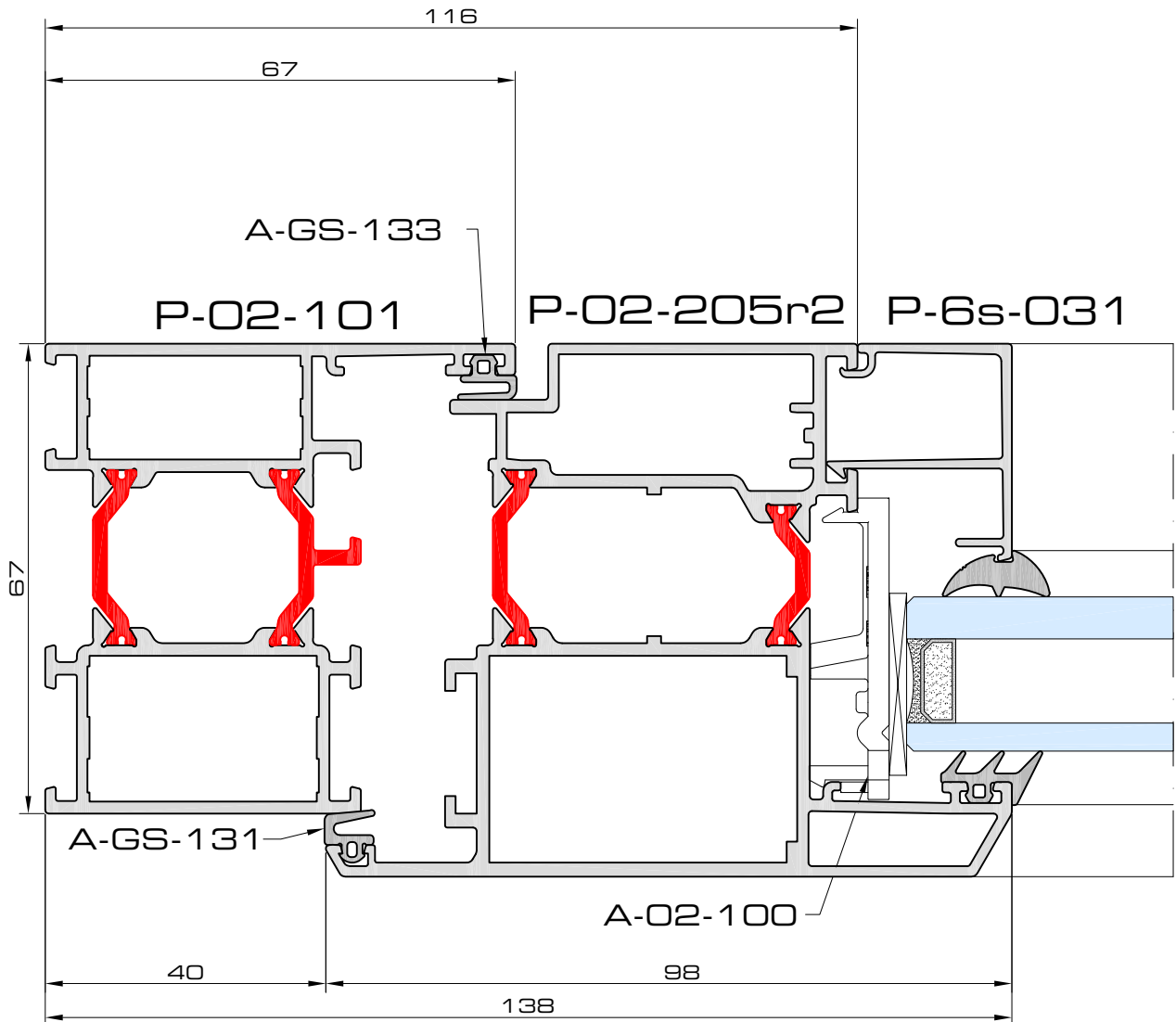
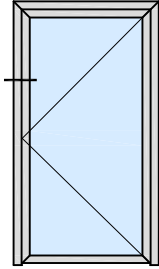

door12

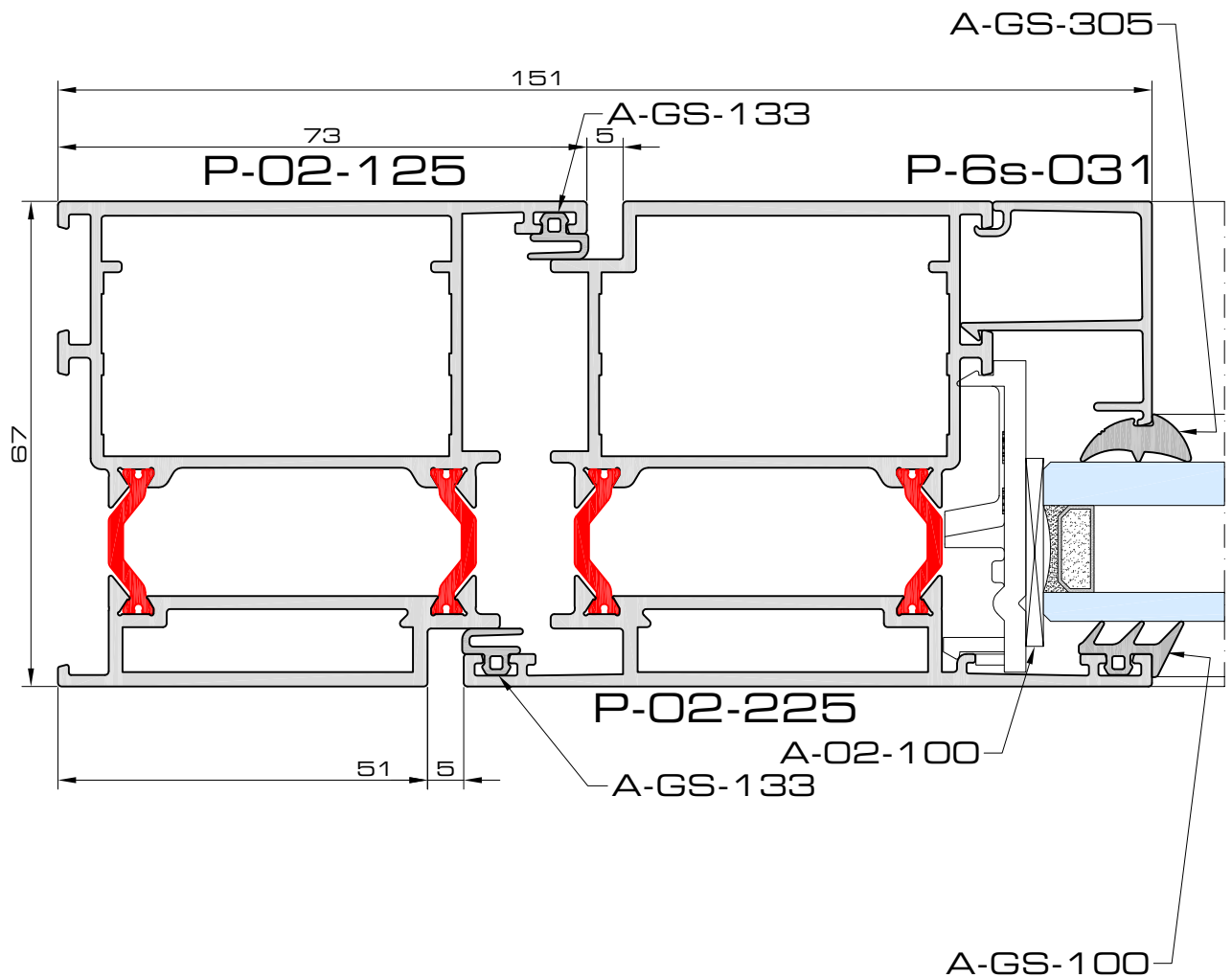
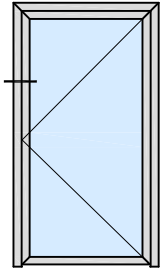
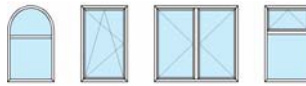

door12b

12c

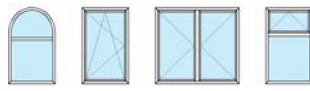

doorsneden ■ coupes ■ sections

HerCules P02

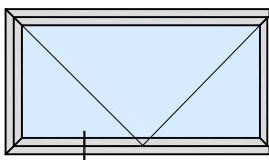
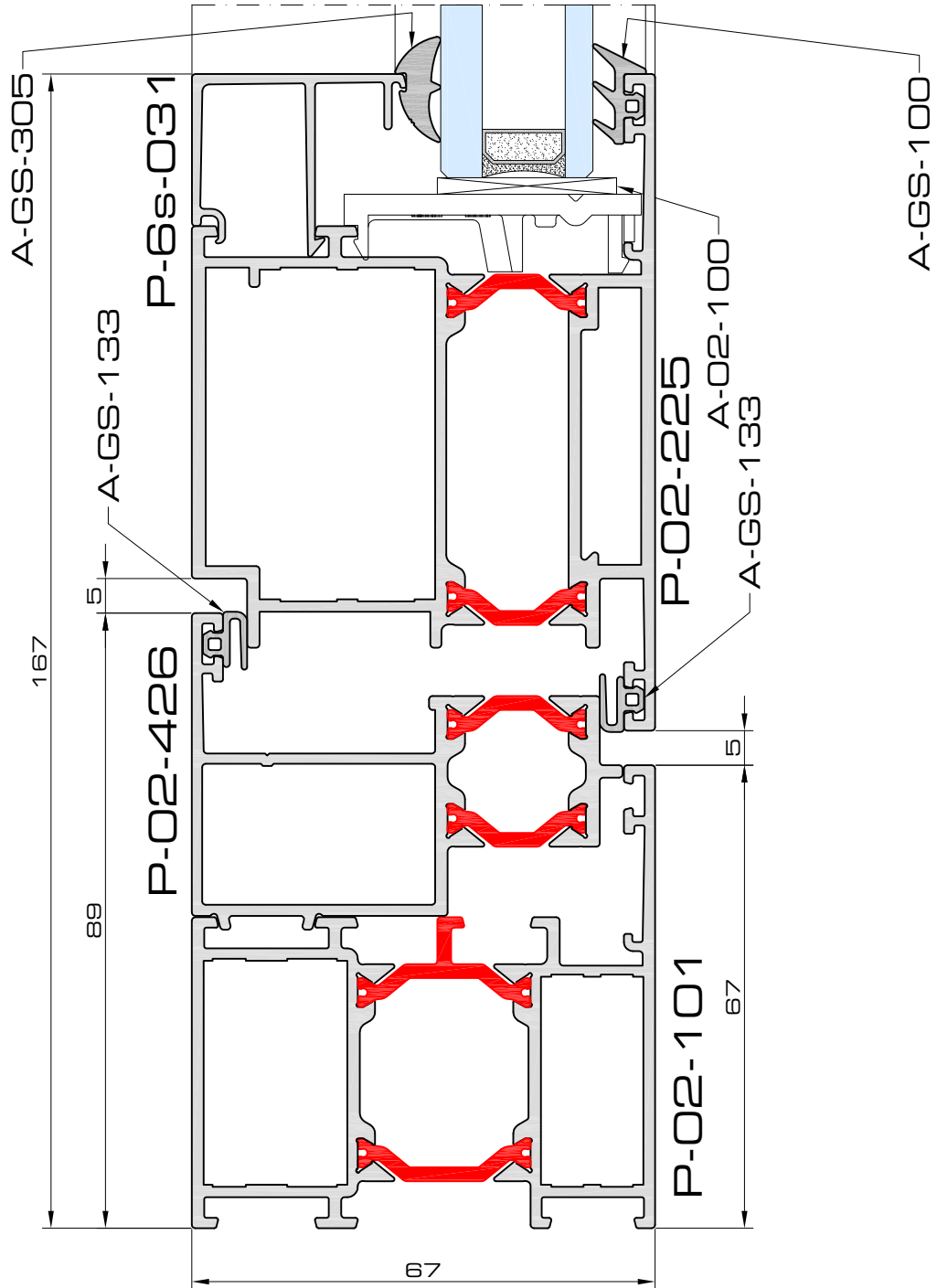

door12c

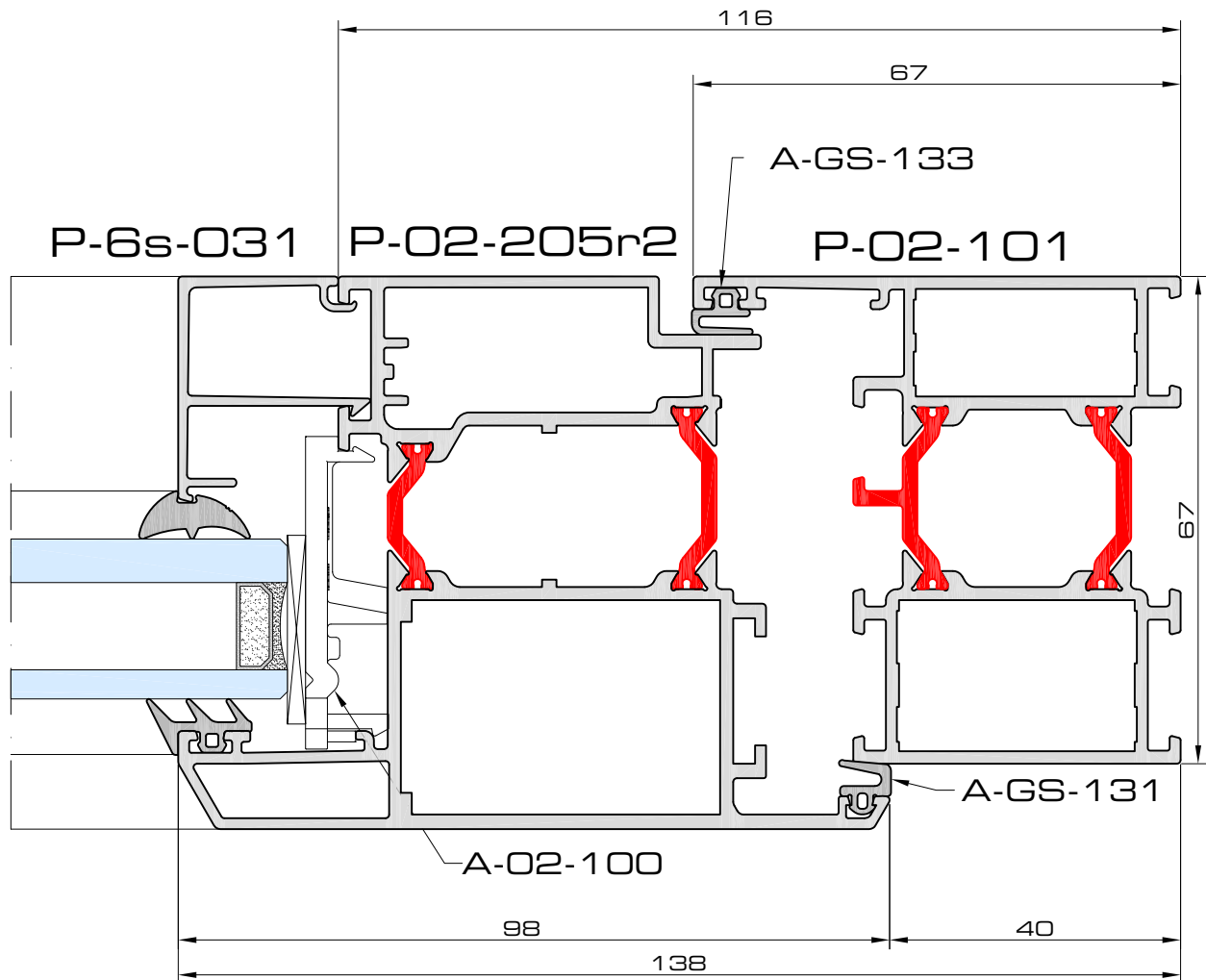
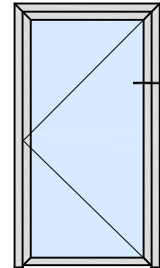

door13

13b

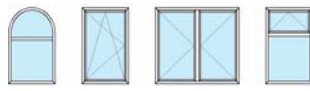

doorsneden ■ coupes ■ sections

Hercules P02

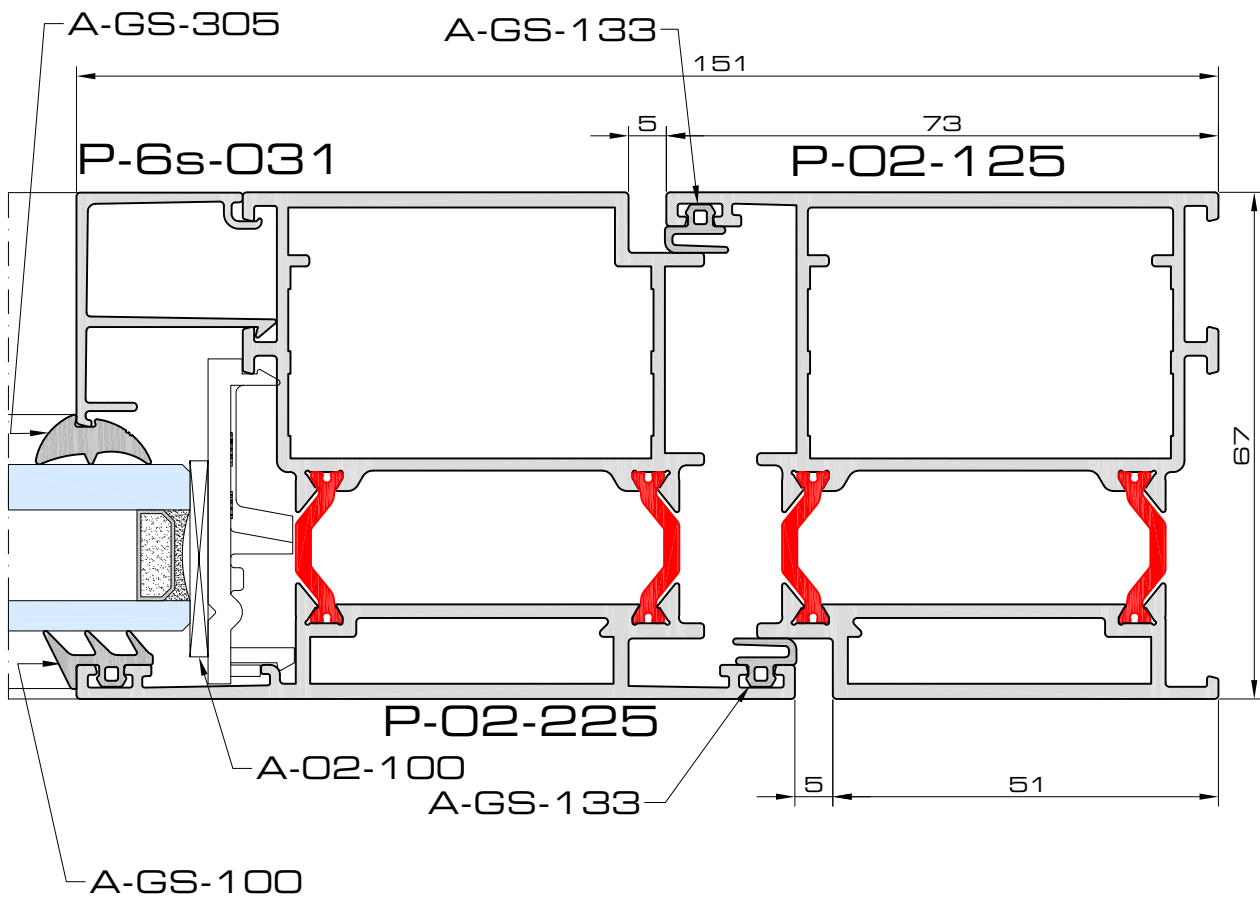
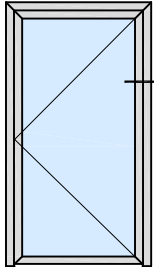

door13b

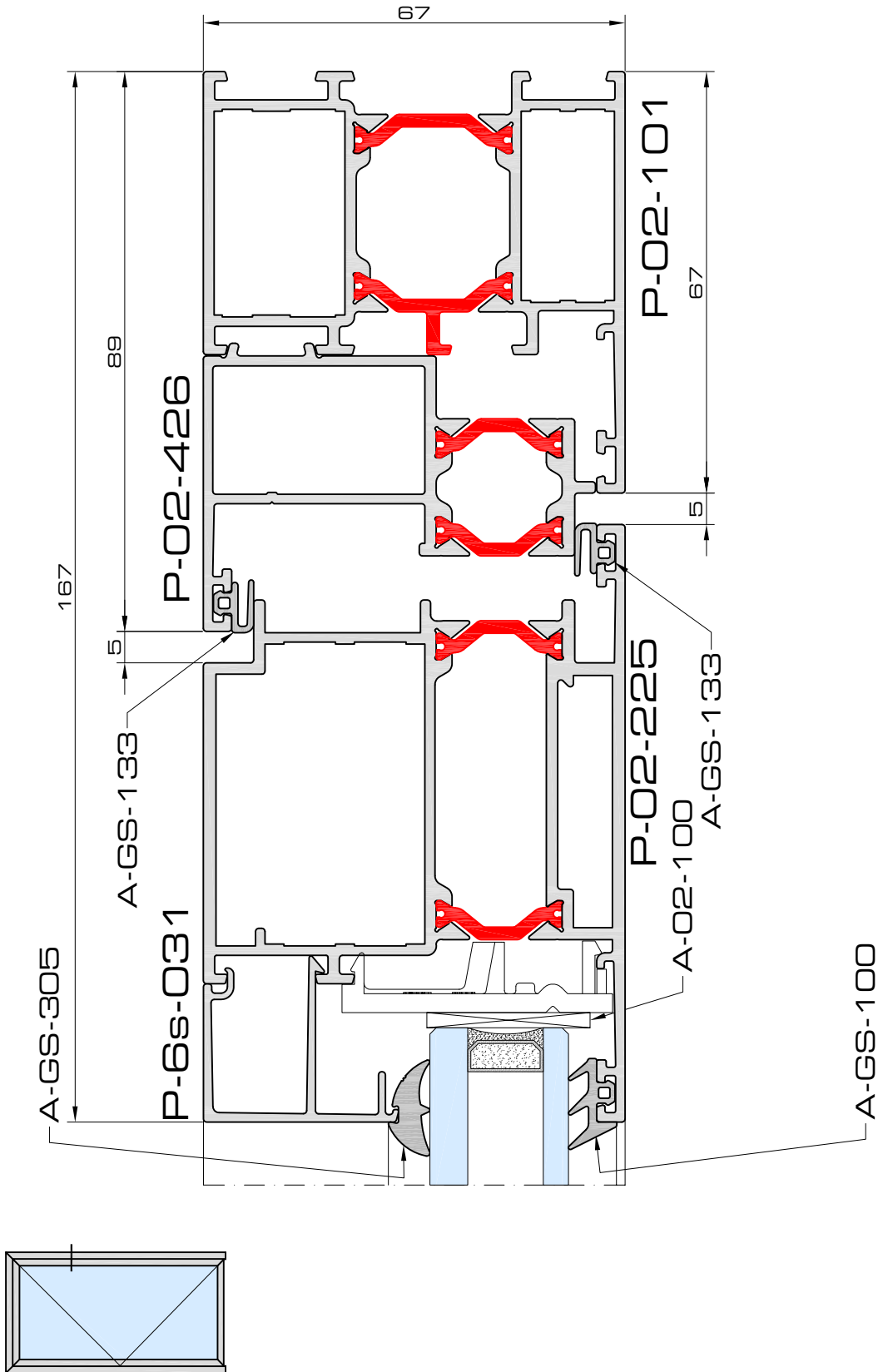
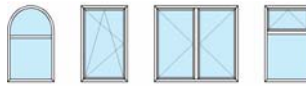

door13c

14a

doorsneden ■ coupes ■ sections



Hercules P02

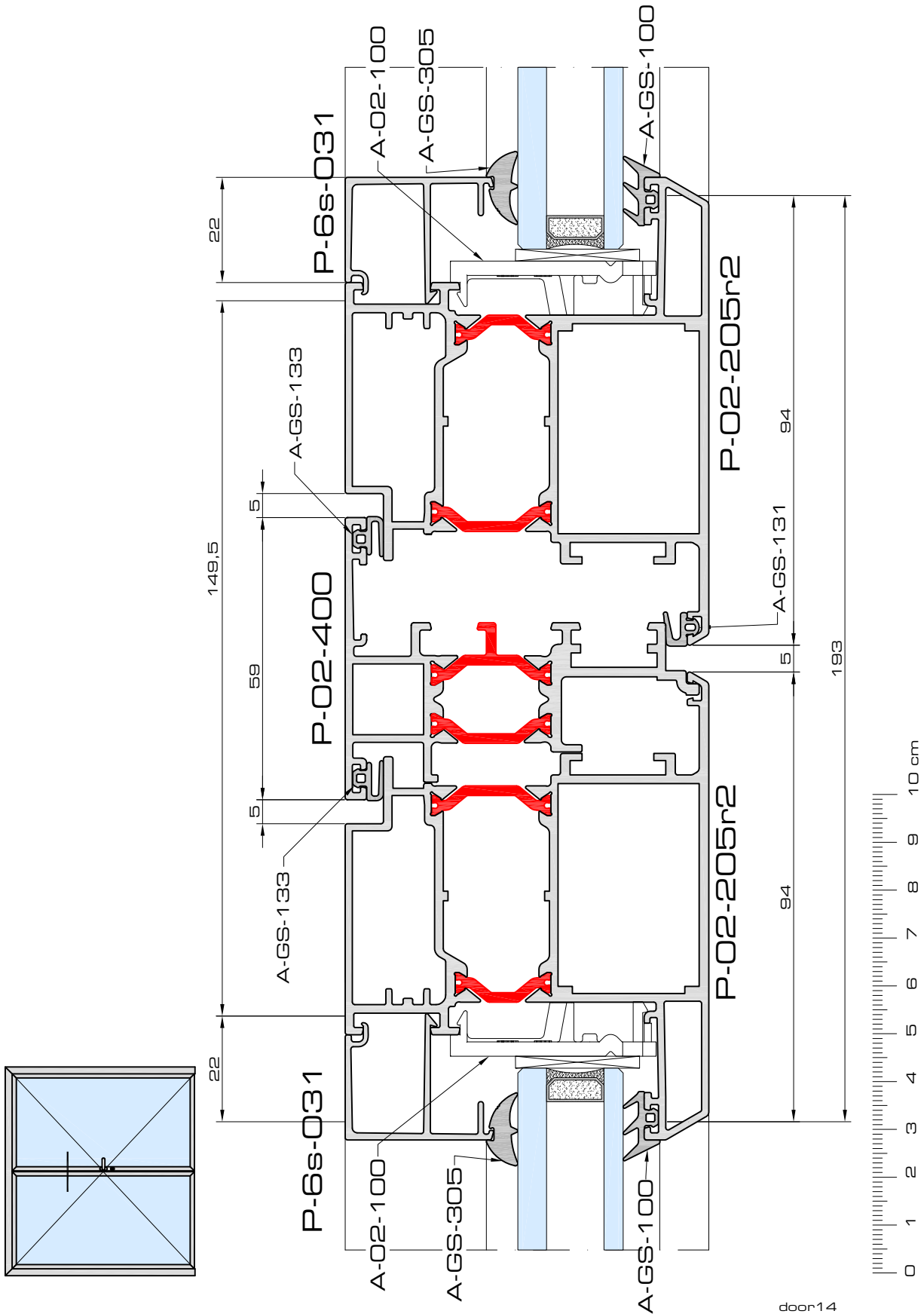

door14

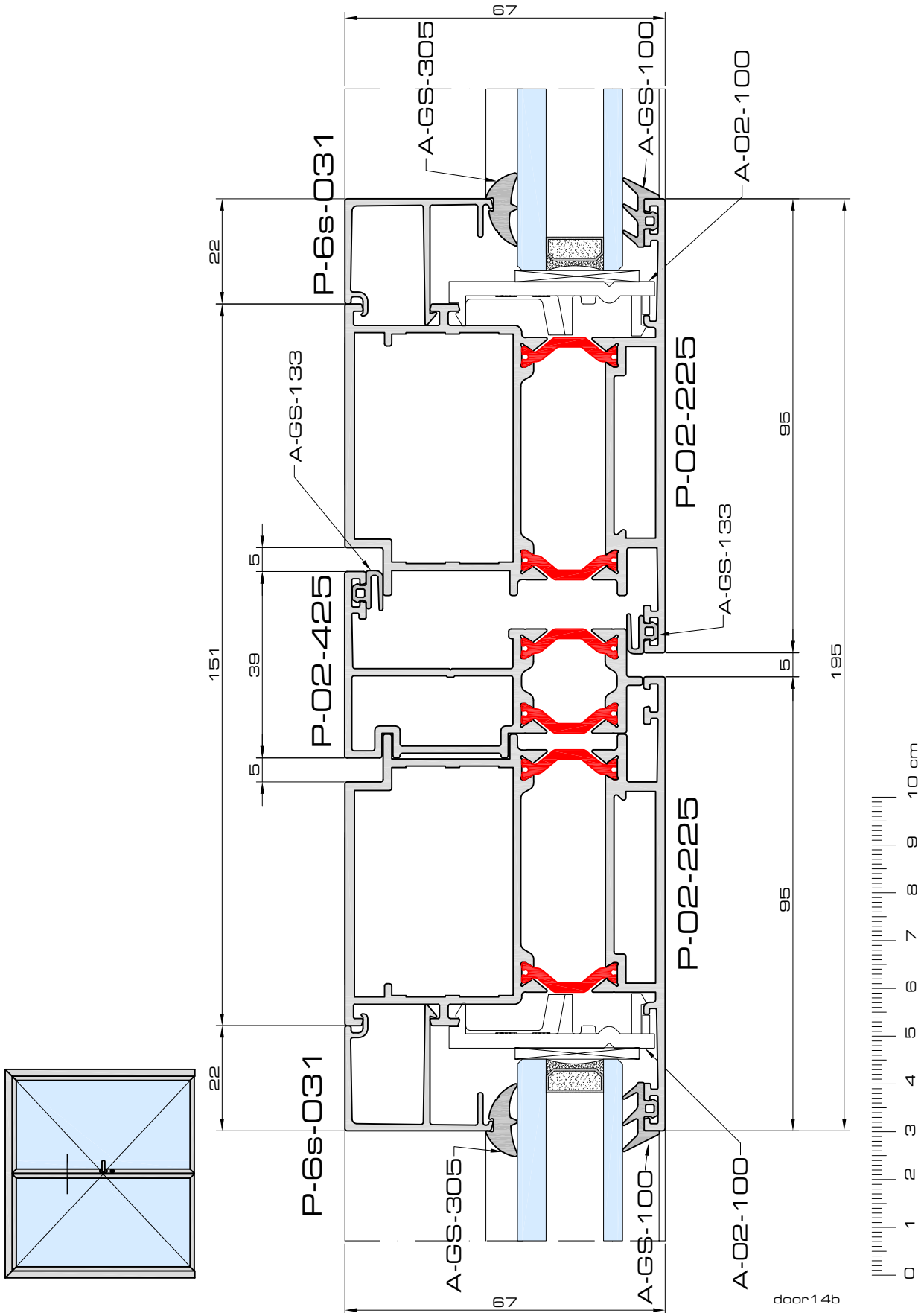
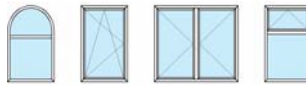

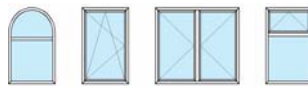

doorsneden ■ coupes ■ sections

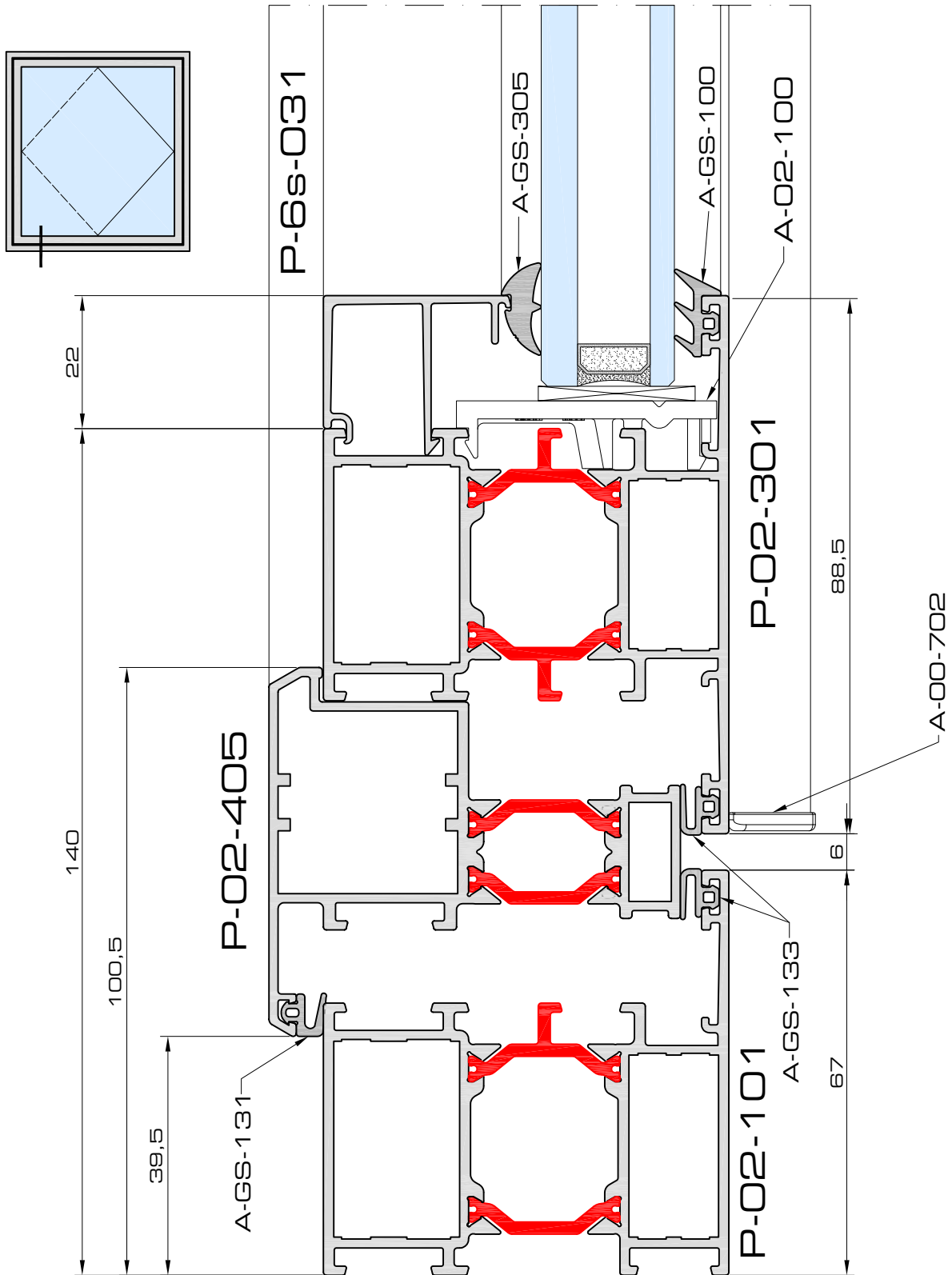

door15

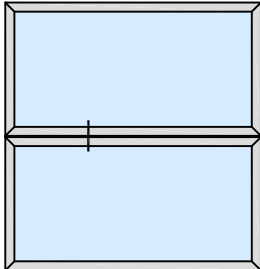
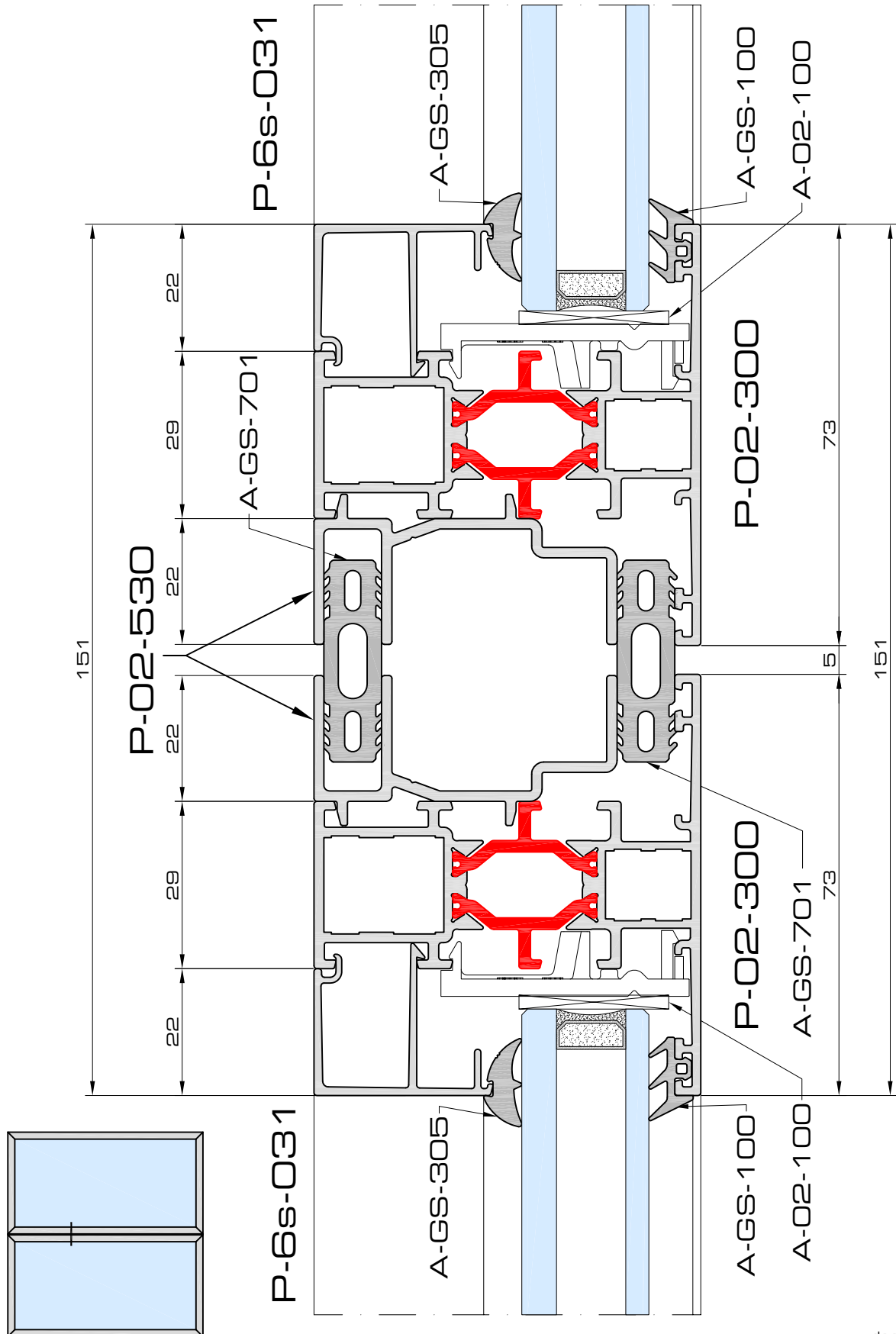

door16

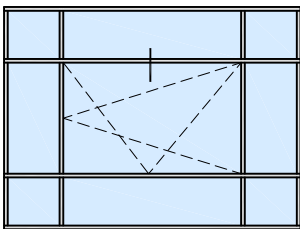
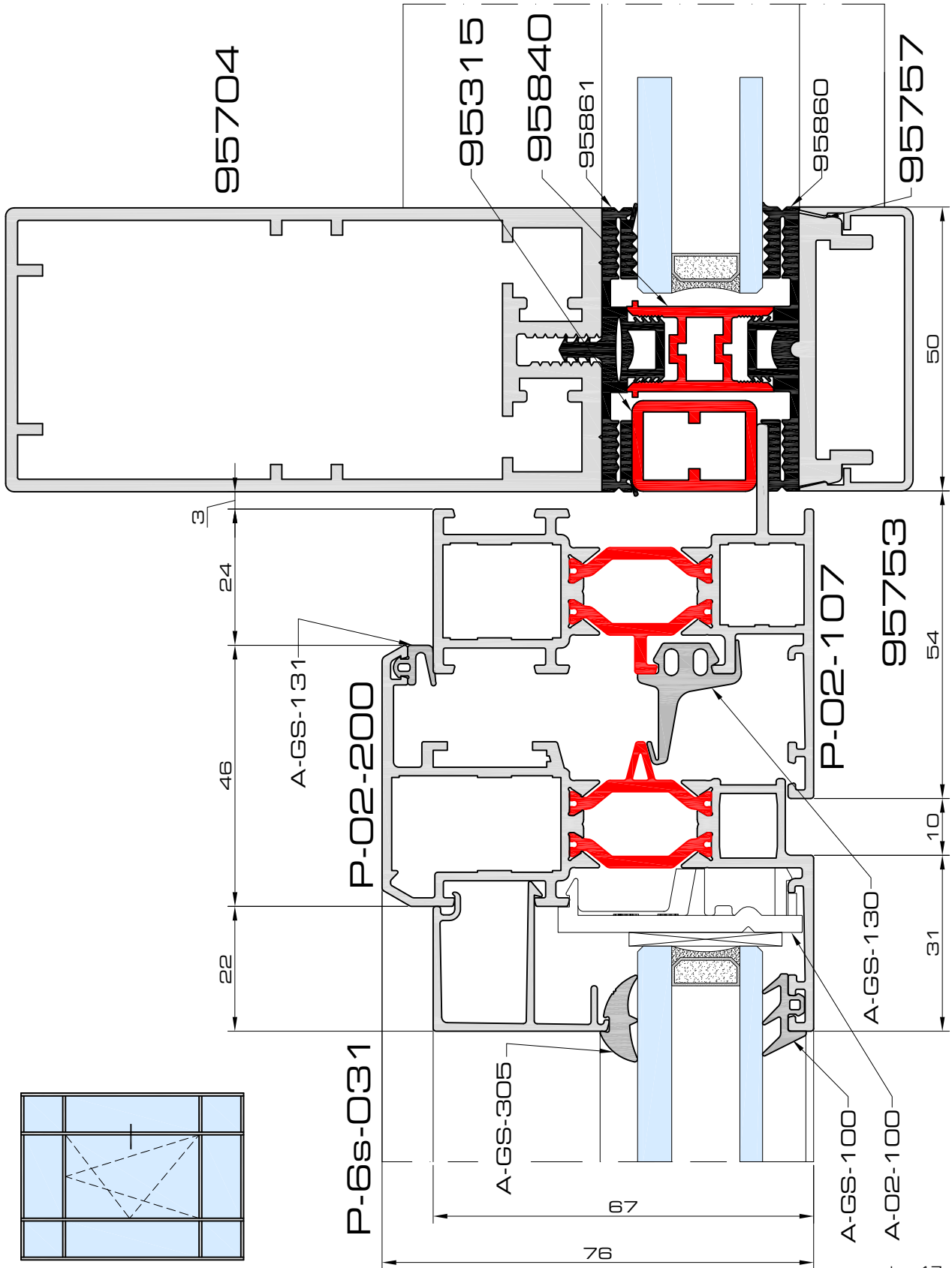
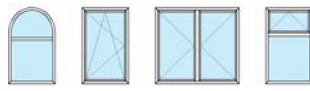

door17

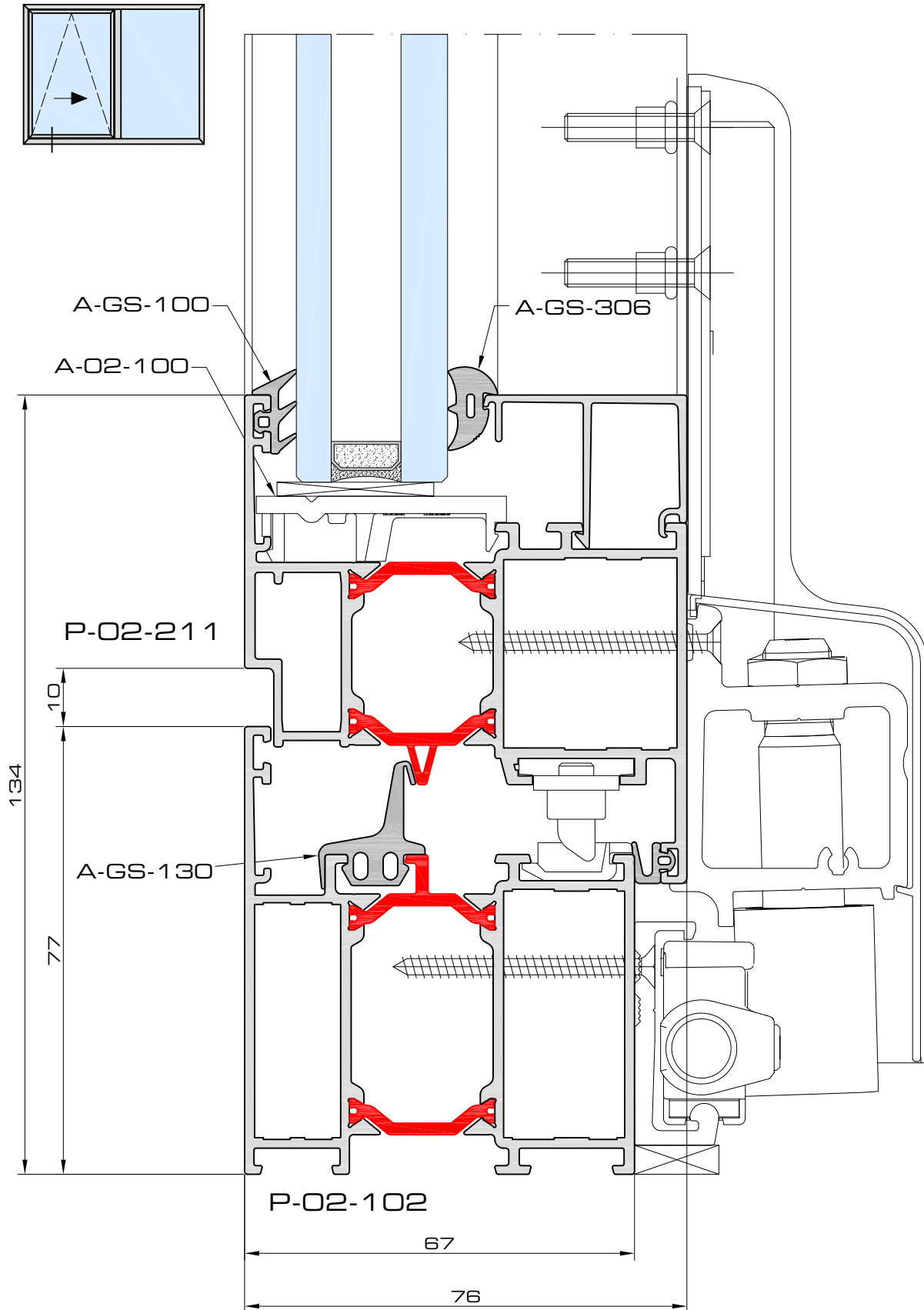

door20

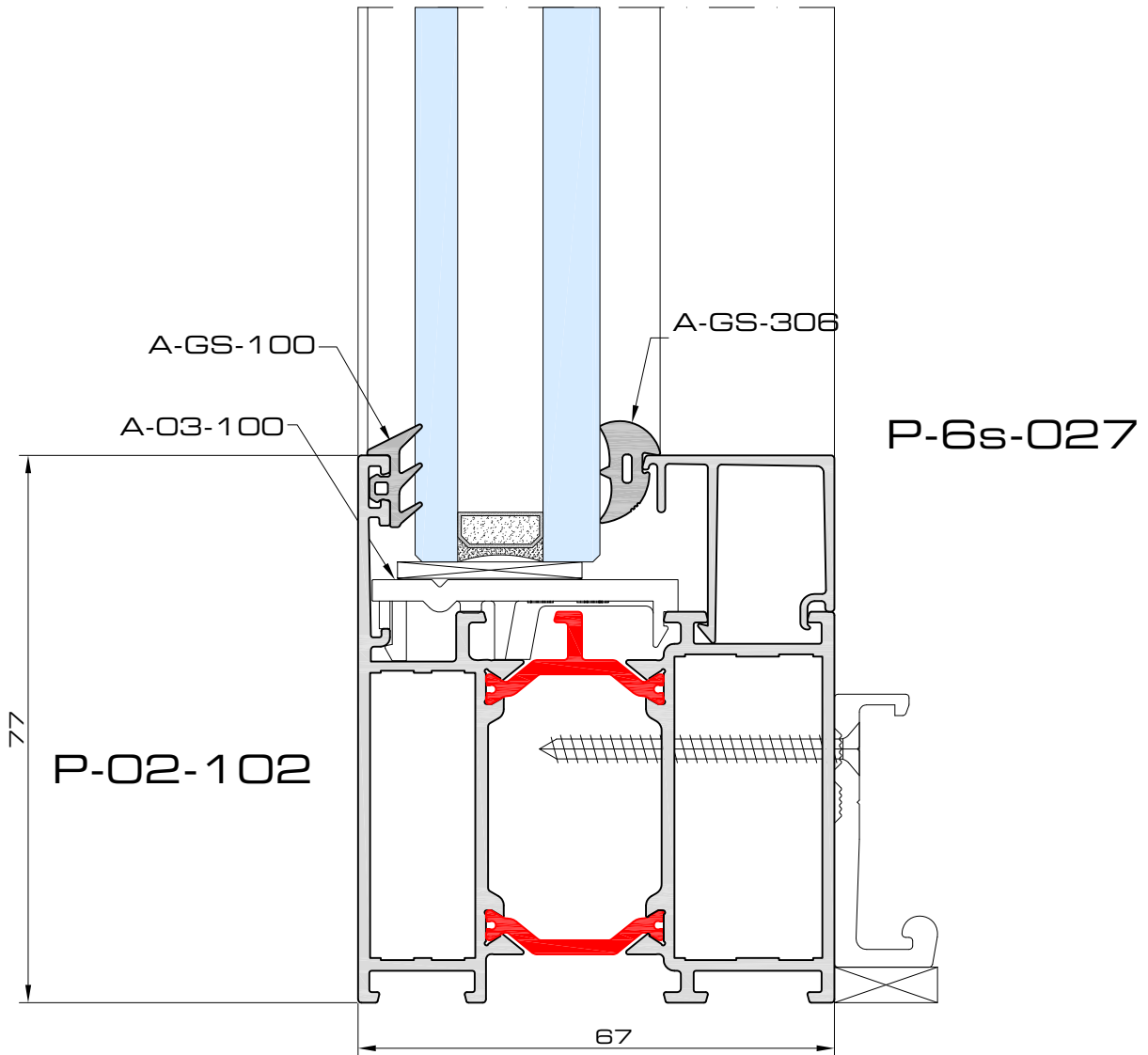
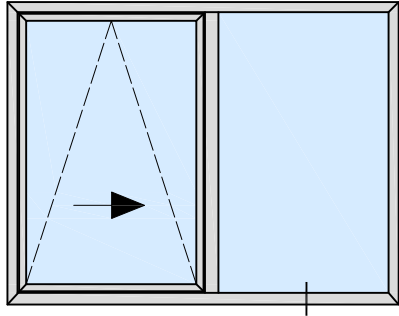
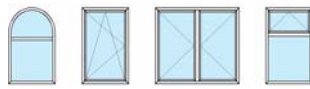

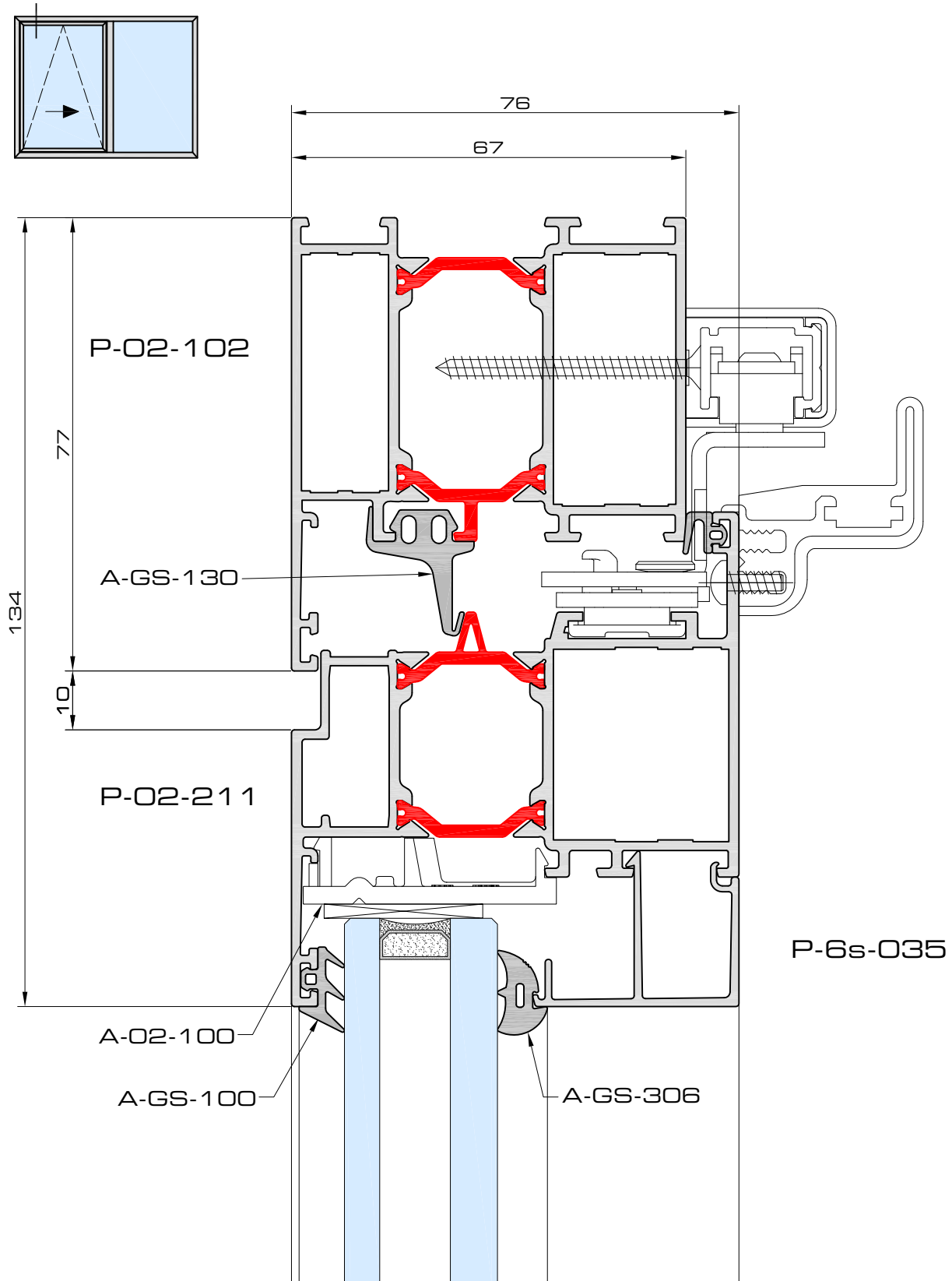

door22

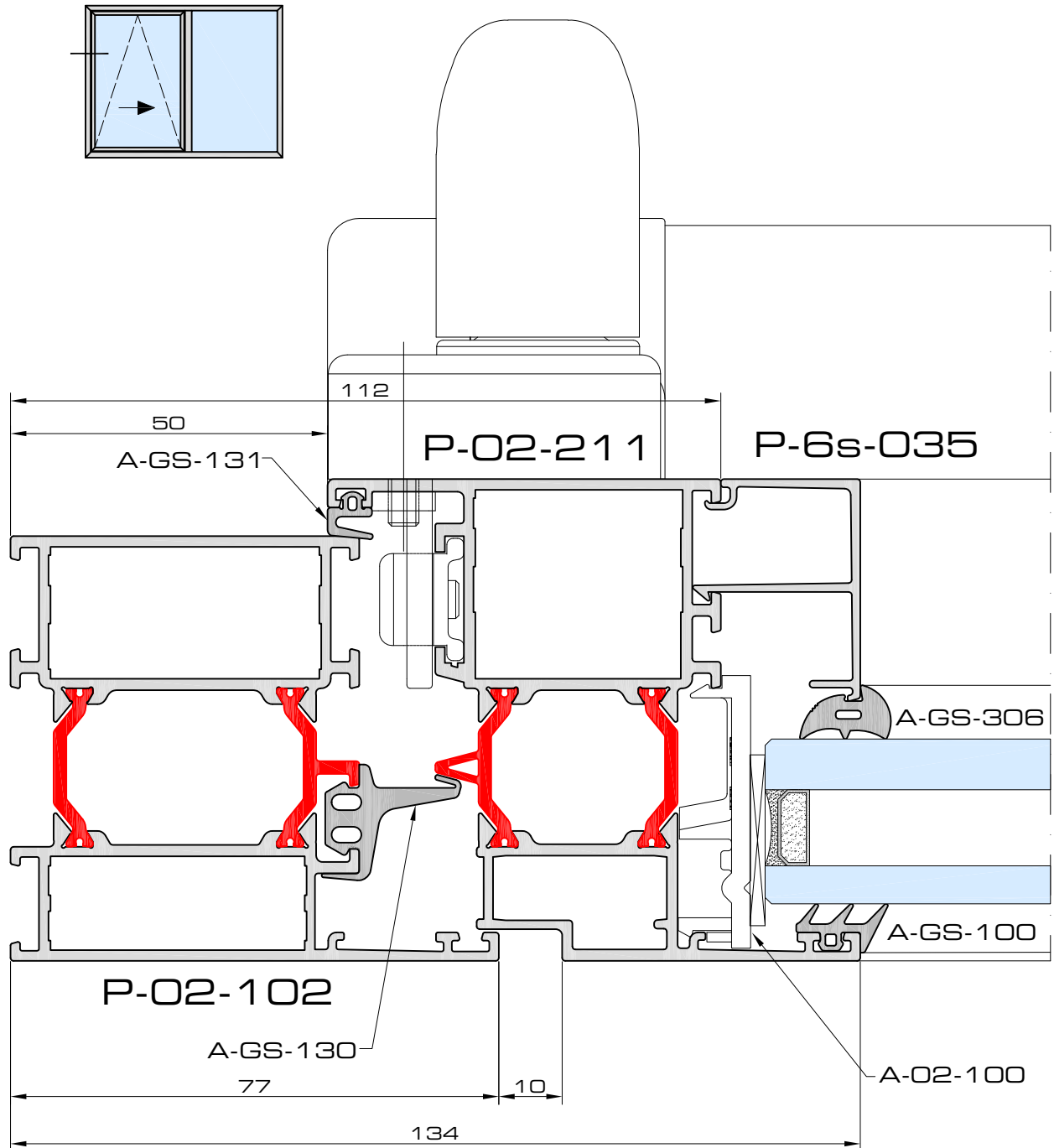
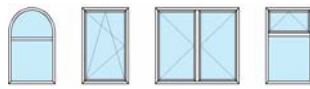

door23

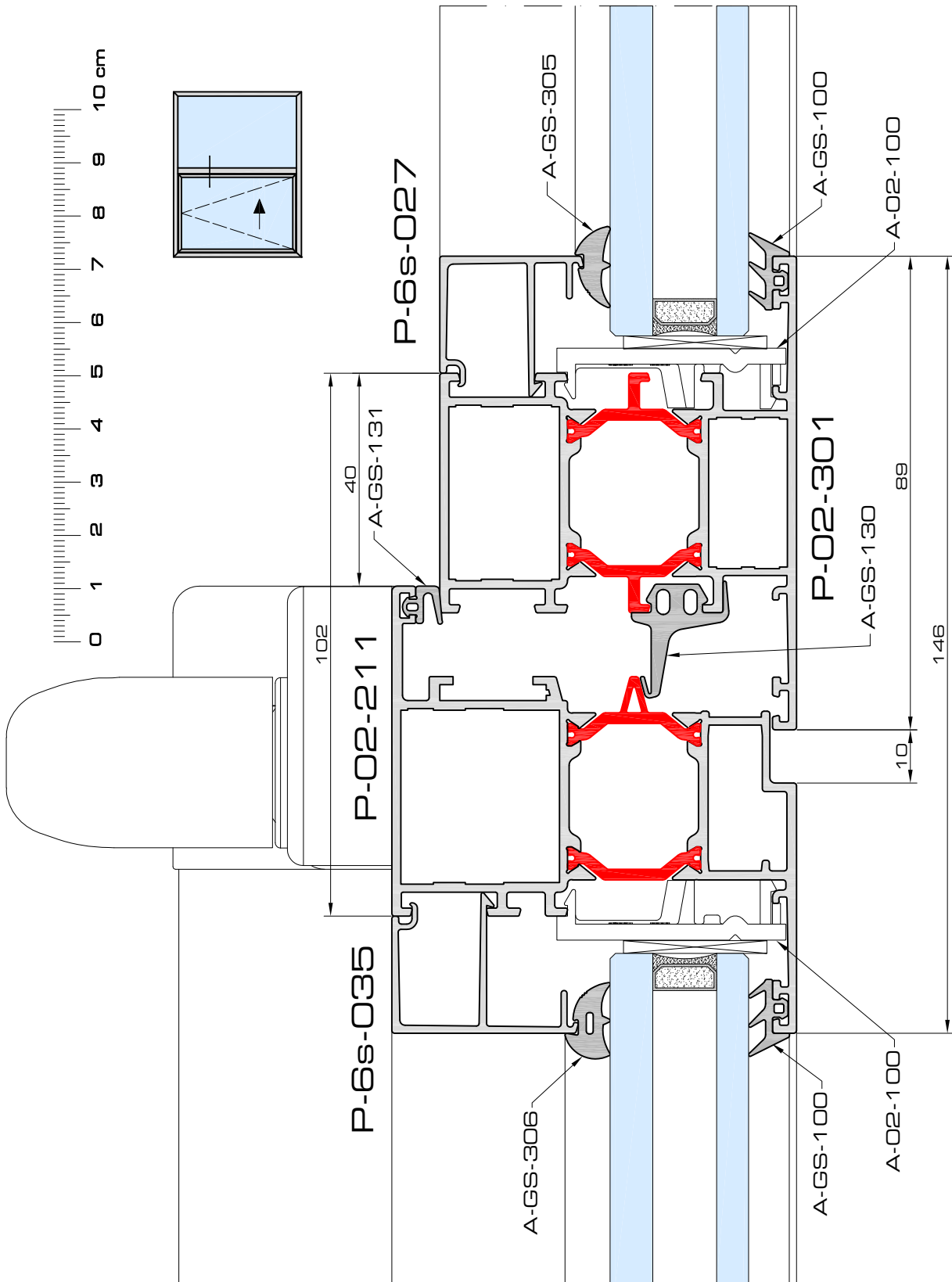
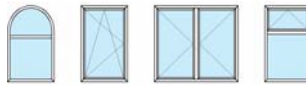

door24

Performances Hercules system



09/2785



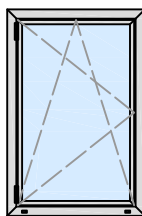



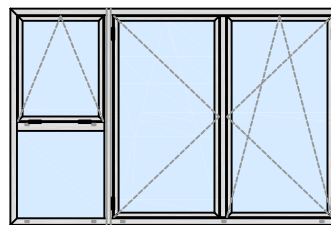





Technical agreement



1230mm x 1480mm



3350mm x 2200mm

	1230mm x 1480mm	3350mm x 2200mm
AIR PERMEABILITY EN 12207 	class 4	class 4
WATER THIGHTNESS EN 12208 	E2000A	E1050A
WIND RESISTANCE EN 12211 	C4	C4
OPERATION FORCE EN 13115 EN 12046-1 	class 1	class 1
WRONG USE EN 13115  80kg	class 4	class 4
IMPACT EN 13049 	-	-
REPORT 	CAR 8187/3 23/09/2008	CAR 8224 23/10/2008
ACOUSTIC PERFORMANCE EN ISO 140-3 EN ISO 717-1 	40 (-1;-5) dB	-
REPORT 	AC 4605 09/06/2008	
BURGLARY PROOF NEN 5096/A1 ENV 1627 	class 2	-
REPORT 	 ATT' 09.11.295.02 system certificate	

Uf values Hercules system

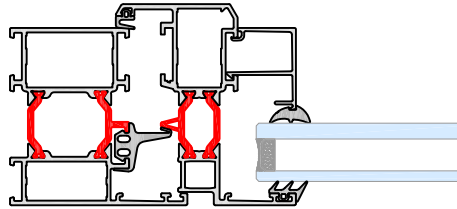

EN ISO 10077-1
EN ISO 10077-2

	-	P-02-200	P-02-201	P-02-202
P-02-100	2.94 W/m²K	3.04 W/m²K	3.01 W/m²K	2.97 W/m²K
P-02-101	2.91 W/m²K	2.99 W/m²K	2.96 W/m²K	2.94 W/m²K
P-02-102	2.89 W/m²K	2.97 W/m²K	2.94 W/m²K	2.93 W/m²K

Uw calculation

EN ISO 10077-1
EN ISO 10077-2

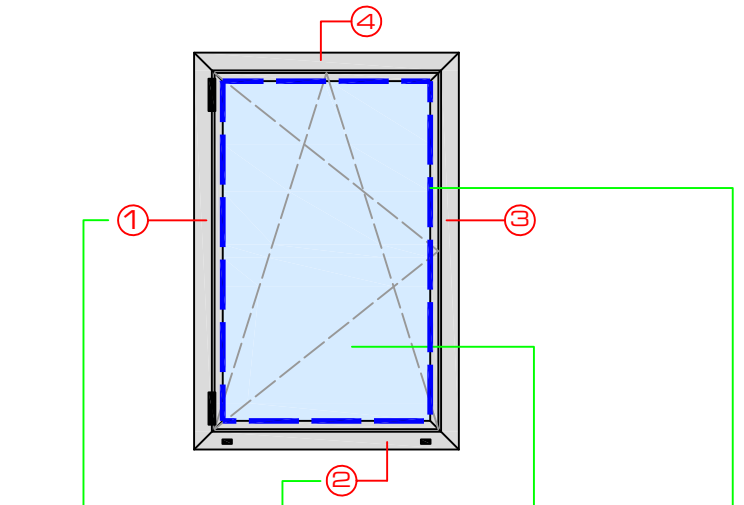

$$U_w = \frac{U_{f1} * A_1 + U_{f2} * A_2 + \dots + U_g * A_g + \psi * L_g}{A_{tot}}$$

- Uw = U value window
- Uf = U value profile
- Ug = U value glass
- A1, A2, A3, A4 = area profile
- Atot = total window area
- Ag = glass area
- Lg = length of glass edge
- ψ = glass edge factor --> 0.11 standard

Example Uw calculation

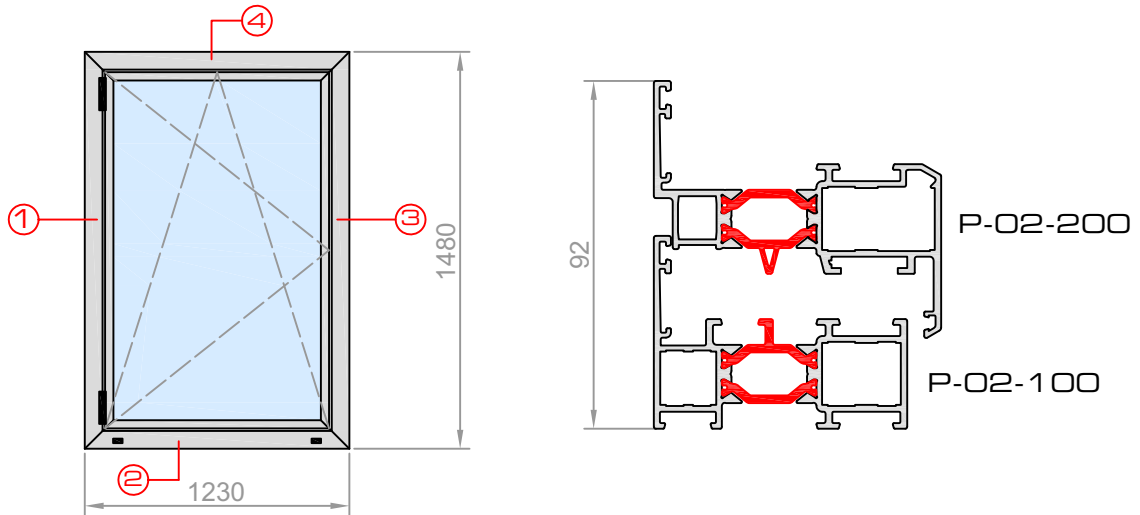

$$U_{f1} = U_{f2} = U_{f3} = U_{f4} = 3.04 \text{ W/m}^2\text{K}$$

$$U_g = 1.1 \text{ W/m}^2\text{K}$$

$$\Psi = 0.11 \text{ (standard)}$$

$$A_1 = A_3$$

$$= 0.127 \text{ m}^2$$

$$A_2 = A_4$$

$$= 0.105 \text{ m}^2$$

$$A_g = 1.35 \text{ m}^2$$

$$L_g = 4.68 \text{ m}$$

$$A_{tot} = 1.82 \text{ m}^2$$

$$U_w = \frac{3.04 * 0.105 + 3.04 * 0.127 + 3.04 * 0.105 + 3.04 * 0.127 + 1.1 * 1.35 + 0.11 * 4.68}{1.82}$$

$$U_w = 1.88 \text{ W/m}^2\text{K}$$

Sterkteberekening in functie van "C"-waarde Calcul statique en fonction du valeur "C" Static calculation according to "C" value

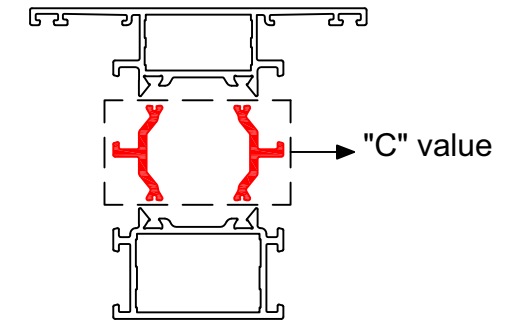

Rekenvoorbeeld Exemple de calcul Calculation example

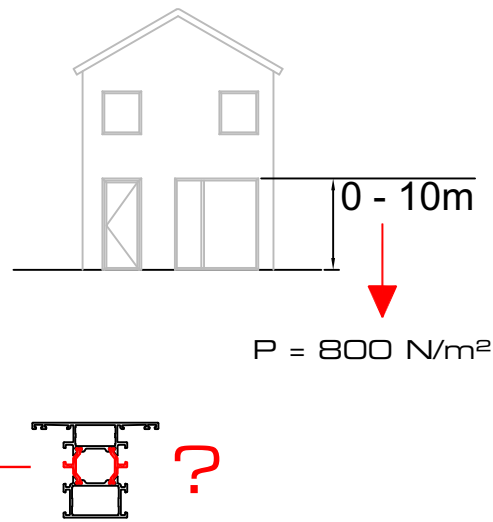
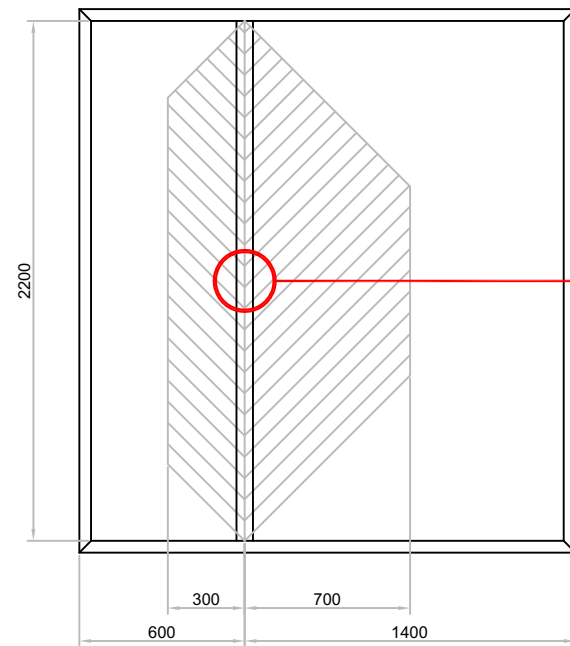

Benodigd traagheidsmoment
Moment d'inertie nécessaire
Required moment of inertia

$P = 800 \text{ N/m}^2$ $f_{\max} = L/225 < 12\text{mm}$

L (mm)	x / y (mm)	200	300	400	500	600	700	800	900	1000	1100	1200	1300	1400	1500
1000	0,63	0,87	1,02	1,07											
1100	0,84	1,18	1,43	1,55											
1200	1,11	1,57	1,92	2,15	2,22										
1300	1,42	2,02	2,51	2,86	3,04										
1400	1,78	2,56	3,21	3,70	4,01	4,12									
1500	2,20	3,18	4,02	4,69	5,16	5,39									
1600	2,67	3,89	4,95	5,83	6,48	6,89	7,02								
1700	3,22	4,69	6,01	7,13	8,00	8,60	8,91								
1800	3,83	5,60	7,21	8,60	9,73	10,56	11,07	11,25							
1900	4,51	6,62	8,55	10,25	11,67	12,77	13,53	13,91							
2000	5,27	7,75	10,04	12,09	13,84	15,26	16,29	16,93	17,14						
2100	6,11	9,00	11,69	14,13	16,25	18,02	19,38	20,31	20,78						
2200	7,04	10,38	13,52	16,38	18,92	21,08	22,81	24,07	24,84	25,10					
2300	8,05	11,89	15,52	18,86	21,85	24,45	26,59	28,23	29,35	29,91					
2400	9,15	13,54	17,70	21,56	25,06	28,14	30,74	32,81	34,32	35,24	35,55				
2500	10,36	15,34	20,08	24,51	28,56	32,17	35,28	37,83	39,78	41,10	41,77				
2600	11,66	17,28	22,66	27,71	32,36	36,55	40,22	43,30	45,74	47,52	48,60	48,96			
2700	13,07	19,38	25,44	31,17	36,48	41,30	45,58	49,24	52,23	54,52	56,06	56,84			
2800	15,12	22,45	29,50	36,19	42,44	48,15	53,27	57,73	61,46	64,42	66,56	67,86	68,30		
2900	17,41	25,86	34,02	41,79	49,08	55,81	61,88	67,24	71,82	75,55	78,39	80,31	81,27		
3000	19,95	29,65	39,04	48,02	56,47	64,32	71,47	77,85	83,38	88,00	91,65	94,29	95,89	96,43	

$I_x = 10.38 \text{ cm}^4 + 21.08 \text{ cm}^4 = 31.46 \text{ cm}^4$

Traagheidsmomenten in functie van "C"-waarde
Moments d'inertie en fonction du valeur "C"
Moments of inertia according to "C" value

	1000	1100	1200	1300	1400	1500	1600	1700	1800	1900	2000	2100	2200	2300	2400	2500	2600	2700	2800	2900	3000
P-02-300	10,20	11,01	12,04	12,85	13,78	14,58	15,38	16,11	16,80	17,33	18,07	18,56	19,18	19,68	20,16	20,60	21,01	21,41	21,76	22,02	22,42
P-02-301	11,71	12,64	13,83	14,75	15,87	16,98	17,78	18,50	19,52	20,25	21,10	21,89	22,51	23,18	23,75	24,35	24,86	25,29	25,84	26,23	26,71
P-02-302	12,58	13,72	14,97	16,23	17,28	18,37	19,44	20,39	21,41	22,27	23,20	23,91	24,79	25,42	26,21	26,80	27,47	27,68	28,59	29,07	29,58
P-02-303	16,81	18,16	19,43	20,85	22,16	23,54	24,91	26,23	27,63	28,92	30,24	31,61	32,74	33,96	35,08	36,14	37,27	38,33	39,30	40,35	41,18
P-02-304	20,74	22,40	23,96	25,72	27,33	29,03	30,73	32,35	34,08	35,67	37,31	38,99	40,38	41,89	43,27	44,59	45,97	47,28	48,48	49,77	50,80
P-02-305	41,38	43,45	45,43	47,18	49,39	51,31	53,12	54,62	56,55	57,93	59,67	61,25	62,46	63,73	64,95	66,21	67,17	67,87	69,13	69,94	70,87
P-02-306	45,50	47,77	49,94	51,87	54,35	56,42	58,58	60,51	62,54	64,61	66,17	67,79	69,48	70,98	72,45	73,71	75,13	76,44	77,51	78,26	79,65
P-02-310	10,50	11,34	12,40	13,23	14,23	15,23	15,95	16,59	17,51	18,17	18,92	19,64	20,18	20,79	21,31	21,84	22,30	22,68	23,18	23,52	23,95
P-02-311	11,94	13,02	14,21	15,41	16,40	17,44	18,45	19,35	20,32	21,14	22,02	22,69	23,53	24,13	24,88	25,44	26,08	26,28	27,14	27,59	28,08
P-02-312	12,79	13,94	15,12	16,24	17,42	18,41	19,63	20,72	21,69	22,64	23,58	24,43	25,31	26,09	26,86	27,49	28,26	28,90	29,51	30,05	30,64
P-02-313	16,86	18,20	19,48	20,90	22,22	23,60	24,98	26,30	27,70	28,99	30,33	31,69	32,82	34,05	35,17	36,24	37,37	38,43	39,41	40,45	41,29
P-02-315	42,12	44,22	46,24	48,01	50,26	52,22	54,06	55,59	57,55	58,96	60,72	62,33	63,57	64,86	66,10	67,38	68,36	69,07	70,36	71,18	72,13

L > 3000mm
gebruik I_x -> "profielen"
utilise I_x -> "profiles"
use I_x -> "profiles"

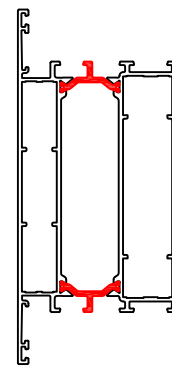

Benodigd traagheidsmoment
 Moment d'inertie nécessaire
 Required moment of inertia

$P = 800 \text{ N/m}^2$

$f_{max} = L/225 < 12\text{mm}$

L (mm)	x / y (mm)													
	200	300	400	500	600	700	800	900	1000	1100	1200	1300	1400	1500
1000	0,63	0,87	1,02	1,07										
1100	0,84	1,18	1,43	1,55										
1200	1,11	1,57	1,92	2,15	2,22									
1300	1,42	2,02	2,51	2,86	3,04									
1400	1,78	2,56	3,21	3,70	4,01	4,12								
1500	2,20	3,18	4,02	4,69	5,16	5,39								
1600	2,67	3,89	4,95	5,83	6,48	6,89	7,02							
1700	3,22	4,69	6,01	7,13	8,00	8,60	8,91							
1800	3,83	5,60	7,21	8,60	9,73	10,56	11,07	11,25						
1900	4,51	6,62	8,55	10,25	11,67	12,77	13,53	13,91						
2000	5,27	7,75	10,04	12,09	13,84	15,26	16,29	16,93	17,14					
2100	6,11	9,00	11,69	14,13	16,25	18,02	19,38	20,31	20,78					
2200	7,04	10,38	13,52	16,38	18,92	21,08	22,81	24,07	24,84	25,10				
2300	8,05	11,89	15,52	18,86	21,85	24,45	26,59	28,23	29,35	29,91				
2400	9,15	13,54	17,70	21,56	25,06	28,14	30,74	32,81	34,32	35,24	35,55			
2500	10,36	15,34	20,08	24,51	28,56	32,17	35,28	37,83	39,78	41,10	41,77			
2600	11,66	17,28	22,66	27,71	32,36	36,55	40,22	43,30	45,74	47,52	48,60	48,96		
2700	13,07	19,38	25,44	31,17	36,48	41,30	45,58	49,24	52,23	54,52	56,06	56,84		
2800	15,12	22,45	29,50	36,19	42,44	48,15	53,27	57,73	61,46	64,42	66,56	67,86	68,30	
2900	17,41	25,86	34,02	41,79	49,08	55,81	61,88	67,24	71,82	75,55	78,39	80,31	81,27	
3000	19,95	29,65	39,04	48,02	56,47	64,32	71,47	77,85	83,38	88,00	91,65	94,29	95,89	96,43

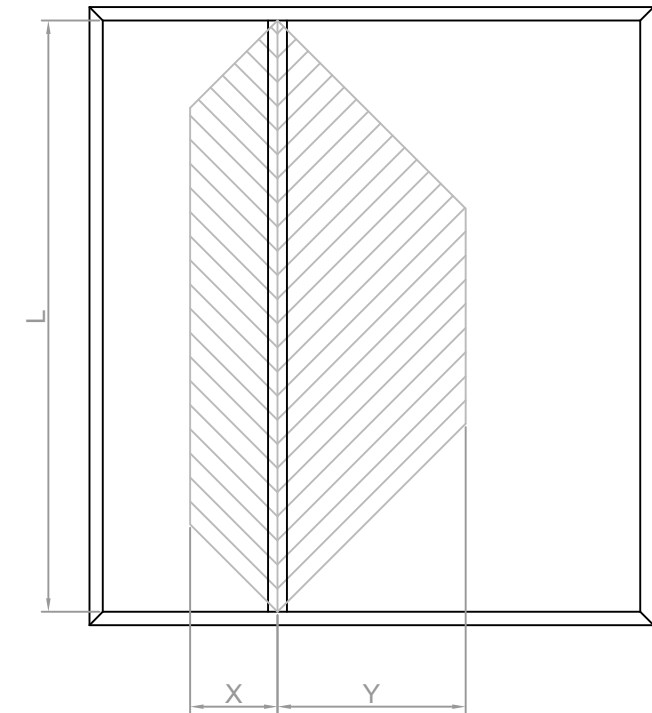

$P = 1200 \text{ N/m}^2$

$f_{max} = L/225 < 12\text{mm}$

L (mm)	x / y (mm)													
	200	300	400	500	600	700	800	900	1000	1100	1200	1300	1400	1500
1000	0,94	1,30	1,53	1,61										
1100	1,27	1,77	2,14	2,33										
1200	1,66	2,35	2,88	3,22	3,33									
1300	2,12	3,03	3,77	4,29	4,56									
1400	2,67	3,84	4,82	5,56	6,02	6,17								
1500	3,29	4,76	6,03	7,04	7,73	8,09								
1600	4,01	5,83	7,43	8,74	9,72	10,33	10,53							
1700	4,83	7,04	9,01	10,69	12,00	12,90	13,37							
1800	5,74	8,40	10,81	12,89	14,59	15,84	16,61	16,87						
1900	6,77	9,93	12,82	15,37	17,50	19,16	20,30	20,87						
2000	7,91	11,62	15,06	18,13	20,76	22,88	24,44	25,39	25,71					
2100	9,17	13,50	17,54	21,19	24,38	27,03	29,07	30,46	31,17					
2200	10,55	15,57	20,27	24,57	28,38	31,62	34,21	36,10	37,26	37,65				
2300	12,07	17,84	23,27	28,29	32,78	36,67	39,88	42,35	44,02	44,87				
2400	13,73	20,31	26,55	32,35	37,60	42,21	46,11	49,22	51,48	52,86	53,32			
2500	15,53	23,00	30,12	36,77	42,84	48,26	52,91	56,74	59,67	61,65	62,65			
2600	17,49	25,92	33,98	41,56	48,55	54,83	60,33	64,94	68,62	71,28	72,90	73,44		
2700	19,60	29,07	38,17	46,75	54,72	61,96	68,37	73,86	78,35	81,78	84,10	85,26		
2800	22,68	33,67	44,25	54,29	63,65	72,23	79,91	86,59	92,19	96,63	99,84	101,79	102,44	
2900	26,11	38,80	51,04	62,69	73,62	83,71	92,83	100,86	107,72	113,32	117,59	120,46	121,91	
3000	29,92	44,48	58,57	72,02	84,71	96,48	107,21	116,78	125,07	132,00	137,48	141,44	143,84	144,64

Benodigd traagheidsmoment
 Moment d'inertie nécessaire
 Required moment of inertia

$P = 1600 \text{ N/m}^2$ $f_{\max} = L/225 < 12\text{mm}$

L (mm)	x / y (mm)													
	200	300	400	500	600	700	800	900	1000	1100	1200	1300	1400	1500
1000	1,25	1,73	2,04	2,14										
1100	1,69	2,37	2,85	3,11										
1200	2,21	3,13	3,84	4,29	4,44									
1300	2,83	4,05	5,03	5,72	6,08									
1400	3,56	5,11	6,42	7,41	8,02	8,23								
1500	4,39	6,35	8,04	9,38	10,31	10,79								
1600	5,35	7,77	9,90	11,66	12,96	13,77	14,04							
1700	6,44	9,38	12,02	14,25	16,00	17,21	17,82							
1800	7,66	11,20	14,41	17,19	19,45	21,12	22,15	22,49						
1900	9,02	13,24	17,09	20,49	23,34	25,55	27,06	27,83						
2000	10,54	15,50	20,08	24,17	27,68	30,51	32,59	33,86	34,29					
2100	12,22	18,00	23,39	28,26	32,51	36,04	38,76	40,62	41,56					
2200	14,07	20,76	27,03	32,77	37,84	42,15	45,61	48,14	49,68	50,20				
2300	16,10	23,78	31,03	37,72	43,71	48,89	53,17	56,46	58,70	59,82				
2400	18,31	27,08	35,40	43,13	50,13	56,28	61,48	65,62	68,64	70,48	71,09			
2500	20,71	30,67	40,16	49,02	57,13	64,34	70,55	75,65	79,56	82,20	83,54			
2600	23,32	34,56	45,31	55,42	64,73	73,11	80,43	86,59	91,49	95,04	97,20	97,92		
2700	26,13	38,76	50,89	62,34	72,96	82,61	91,15	98,47	104,46	109,04	112,13	113,69		
2800	30,24	44,90	59,00	72,38	84,87	96,31	106,55	115,46	122,92	128,84	133,12	135,72	136,59	
2900	34,82	51,73	68,05	83,59	98,17	111,61	123,77	134,48	143,63	151,10	156,78	160,62	162,55	
3000	39,89	59,31	78,09	96,03	112,94	128,64	142,95	155,71	166,77	176,00	183,31	188,59	191,79	192,86

$P = 2000 \text{ N/m}^2$ $f_{\max} = L/225 < 12\text{mm}$

L (mm)	x / y (mm)													
	200	300	400	500	600	700	800	900	1000	1100	1200	1300	1400	1500
1000	1,57	2,16	2,55	2,68										
1100	2,11	2,96	3,56	3,88										
1200	2,77	3,92	4,80	5,36	5,55									
1300	3,54	5,06	6,28	7,15	7,59									
1400	4,44	6,39	8,03	9,26	10,03	10,29								
1500	5,49	7,94	10,05	11,73	12,89	13,49								
1600	6,69	9,72	12,38	14,57	16,20	17,21	17,55							
1700	8,04	11,73	15,02	17,81	20,00	21,51	22,28							
1800	9,57	14,00	18,01	21,49	24,31	26,40	27,69	28,12						
1900	11,28	16,54	21,37	25,61	29,17	31,94	33,83	34,79						
2000	13,18	19,37	25,10	30,22	34,60	38,14	40,73	42,32	42,86					
2100	15,28	22,50	29,23	35,32	40,64	45,05	48,45	50,77	51,95					
2200	17,59	25,95	33,79	40,96	47,30	52,69	57,02	60,17	62,10	62,75				
2300	20,12	29,73	38,79	47,14	54,63	61,12	66,47	70,58	73,37	74,78				
2400	22,89	33,85	44,25	53,91	62,66	70,35	76,85	82,03	85,80	88,10	88,87			
2500	25,89	38,34	50,19	61,28	71,41	80,43	88,19	94,57	99,45	102,75	104,42			
2600	29,15	43,20	56,64	69,27	80,91	91,39	100,54	108,24	114,36	118,80	121,50	122,40		
2700	32,66	48,46	63,61	77,92	91,20	103,26	113,94	123,09	130,58	136,30	140,16	142,11		
2800	37,80	56,12	73,75	90,48	106,09	120,38	133,18	144,32	153,65	161,05	166,40	169,65	170,74	
2900	43,52	64,66	85,06	104,48	122,71	139,51	154,71	168,10	179,54	188,87	195,98	200,77	203,18	
3000	49,87	74,13	97,61	120,04	141,18	160,80	178,69	194,63	208,46	220,00	229,13	235,74	239,73	241,07

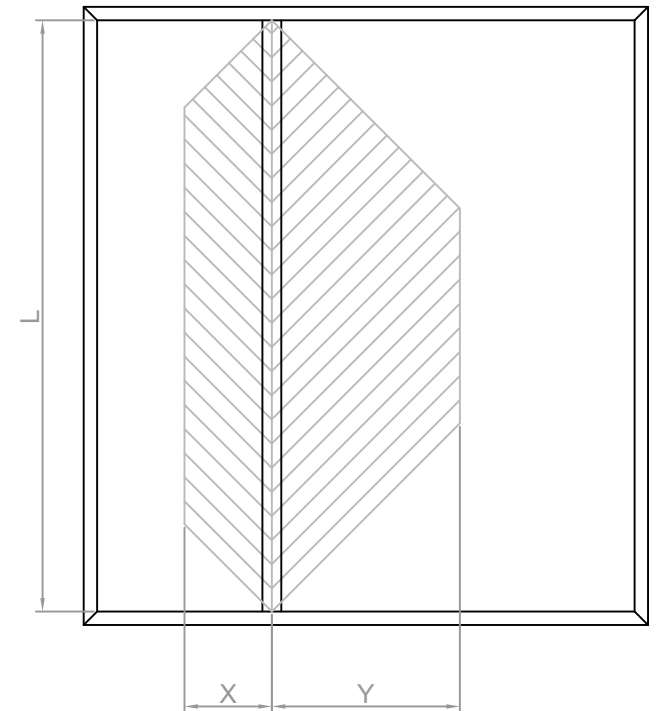

Traagheidsmomenten in functie van "C"-waarde
 Moments d'inertie en fonction du valeur "C"
 Moments of inertia according to "C" value

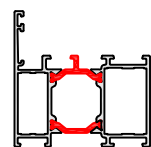

	1000	1100	1200	1300	1400	1500	1600	1700	1800	1900	2000	2100	2200	2300	2400	2500	2600	2700	2800	2900	3000
P-02-100	9,48	10,24	11,12	11,85	12,64	13,28	14,02	14,60	15,25	15,74	16,32	16,79	17,27	17,64	18,09	18,59	18,80	19,16	19,42	19,73	19,97
P-02-101	11,05	11,93	13,05	13,92	14,94	15,80	16,66	17,46	18,21	18,78	19,58	20,11	20,79	21,32	21,84	22,32	22,77	23,20	23,58	23,86	24,29
P-02-102	11,95	12,91	14,11	15,06	16,20	17,33	18,15	18,88	19,93	20,68	21,54	22,35	22,98	23,67	24,25	24,86	25,38	25,82	26,38	26,77	27,27
P-02-107	9,56	10,32	11,29	12,04	12,92	13,66	14,41	15,10	15,75	16,24	16,93	17,39	17,98	18,44	18,89	19,30	19,69	20,07	20,39	20,64	21,01
P-02-109	44,74	46,98	49,11	51,00	53,45	55,48	57,60	59,50	61,49	63,53	65,07	66,66	68,32	69,79	71,24	72,48	73,87	75,16	76,22	76,95	78,32
P-02-110	56,98	59,83	62,56	64,95	68,00	70,65	73,13	75,21	77,86	79,77	82,15	84,33	86,00	87,75	89,43	91,16	92,48	93,44	95,19	96,29	97,58
P-02-111	10,95	11,83	12,94	13,80	14,81	15,66	16,52	17,30	18,05	18,62	19,41	19,93	20,60	21,14	21,65	22,12	22,57	23,00	23,38	23,66	24,08
P-02-113	12,37	13,36	14,61	15,59	16,77	17,94	18,79	19,55	20,63	21,40	22,30	23,14	23,78	24,50	25,10	25,73	26,27	26,72	27,31	27,71	28,23
P-02-115	52,64	55,27	57,80	60,01	62,83	65,28	67,57	69,49	71,94	73,70	75,90	77,91	79,46	81,07	82,63	84,23	85,44	86,33	87,94	88,96	90,16

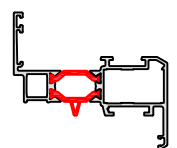

	1000	1100	1200	1300	1400	1500	1600	1700	1800	1900	2000	2100	2200	2300	2400	2500	2600	2700	2800	2900	3000
P-02-200	14,08	15,07	16,34	17,60	18,45	19,29	20,35	21,12	22,03	22,81	23,51	24,08	24,80	25,35	25,93	26,47	26,90	27,32	27,75	28,16	28,49
P-02-201	16,48	17,80	19,07	20,60	21,54	22,91	23,84	24,89	25,92	26,70	27,79	28,68	29,44	30,16	30,91	31,65	32,20	32,63	33,33	33,79	34,33
P-02-202	17,81	19,23	20,57	22,08	23,25	24,57	25,78	27,07	28,12	29,20	30,23	31,16	32,14	33,12	33,83	34,55	35,35	35,97	36,69	37,40	37,88
P-02-210	14,25	15,25	16,54	17,81	18,67	19,52	20,59	21,38	22,30	23,09	23,80	24,37	25,10	25,65	26,24	26,79	27,23	27,65	28,09	28,50	28,84
P-02-211	16,63	17,96	19,21	20,63	21,72	22,95	24,08	25,28	26,26	27,28	28,24	29,11	30,02	30,94	31,60	32,27	33,02	33,60	34,27	34,93	35,38
P-02-212	18,06	19,50	20,85	22,39	23,58	24,92	26,15	27,45	28,51	29,61	30,66	31,60	32,59	33,59	34,31	35,03	35,84	36,47	37,20	37,92	38,41
P-02-220	13,16	14,08	15,27	16,45	17,24	18,03	19,02	19,74	20,60	21,32	21,98	22,51	23,18	23,69	24,23	24,74	25,14	25,53	25,94	26,32	26,63
P-02-230	15,34	16,57	17,75	19,17	20,05	21,32	22,19	23,16	24,13	24,85	25,86	26,69	27,40	28,07	28,77	29,45	29,97	30,37	31,02	31,45	31,95
P-02-231	17,13	18,50	19,79	21,24	22,37	23,64	24,81	26,04	27,05	28,10	29,09	29,98	30,92	31,87	32,55	33,24	34,01	34,61	35,30	35,98	36,44

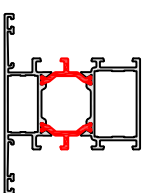



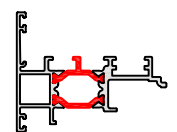



	1000	1100	1200	1300	1400	1500	1600	1700	1800	1900	2000	2100	2200	2300	2400	2500	2600	2700	2800	2900	3000
P-02-300	10,20	11,01	12,04	12,85	13,78	14,58	15,38	16,11	16,80	17,33	18,07	18,56	19,18	19,68	20,16	20,60	21,01	21,41	21,76	22,02	22,42
P-02-301	11,71	12,64	13,83	14,75	15,87	16,98	17,78	18,50	19,52	20,25	21,10	21,89	22,51	23,18	23,75	24,35	24,86	25,29	25,84	26,23	26,71
P-02-302	12,58	13,72	14,97	16,23	17,28	18,37	19,44	20,39	21,41	22,27	23,20	23,91	24,79	25,42	26,21	26,80	27,47	27,68	28,59	29,07	29,58
P-02-303	16,81	18,16	19,43	20,85	22,16	23,54	24,91	26,23	27,63	28,92	30,24	31,61	32,74	33,96	35,08	36,14	37,27	38,33	39,30	40,35	41,18
P-02-304	20,74	22,40	23,96	25,72	27,33	29,03	30,73	32,35	34,08	35,67	37,31	38,99	40,38	41,89	43,27	44,59	45,97	47,28	48,48	49,77	50,80
P-02-305	41,38	43,45	45,43	47,18	49,39	51,31	53,12	54,62	56,55	57,93	59,67	61,25	62,46	63,73	64,95	66,21	67,17	67,87	69,13	69,94	70,87
P-02-306	45,50	47,77	49,94	51,87	54,35	56,42	58,58	60,51	62,54	64,61	66,17	67,79	69,48	70,98	72,45	73,71	75,13	76,44	77,51	78,26	79,65
P-02-310	10,50	11,34	12,40	13,23	14,23	15,23	15,95	16,59	17,51	18,17	18,92	19,64	20,18	20,79	21,31	21,84	22,30	22,68	23,18	23,52	23,95
P-02-311	11,94	13,02	14,21	15,41	16,40	17,44	18,45	19,35	20,32	21,14	22,02	22,69	23,53	24,13	24,88	25,44	26,08	26,28	27,14	27,59	28,08
P-02-312	12,79	13,94	15,12	16,24	17,42	18,41	19,63	20,72	21,69	22,64	23,58	24,43	25,31	26,09	26,86	27,49	28,26	28,90	29,51	30,05	30,64
P-02-313	16,86	18,20	19,48	20,90	22,22	23,60	24,98	26,30	27,70	28,99	30,33	31,69	32,82	34,05	35,17	36,24	37,37	38,43	39,41	40,45	41,29
P-02-315	42,12	44,22	46,24	48,01	50,26	52,22	54,06	55,59	57,55	58,96	60,72	62,33	63,57	64,86	66,10	67,38	68,36	69,07	70,36	71,18	72,13

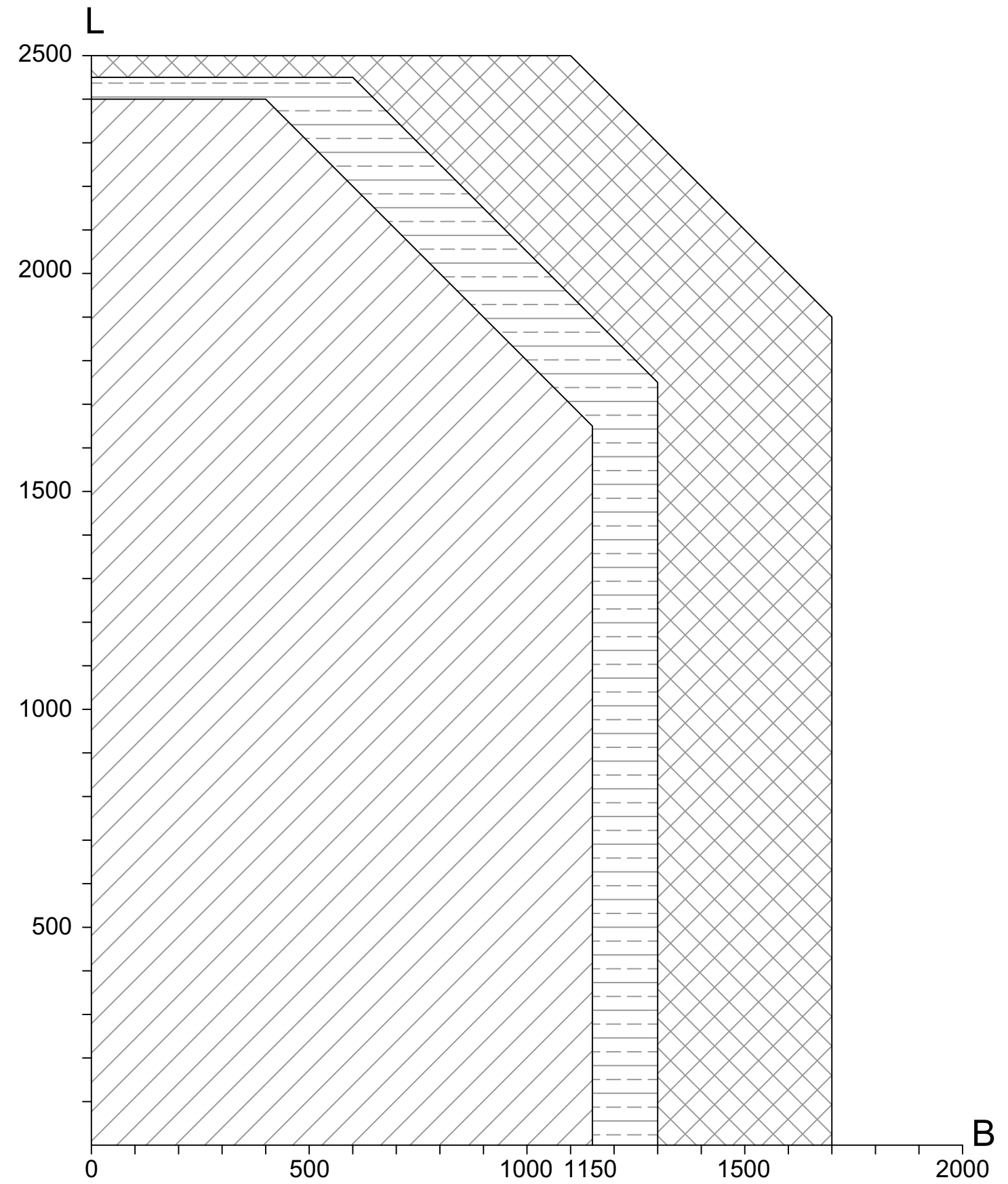
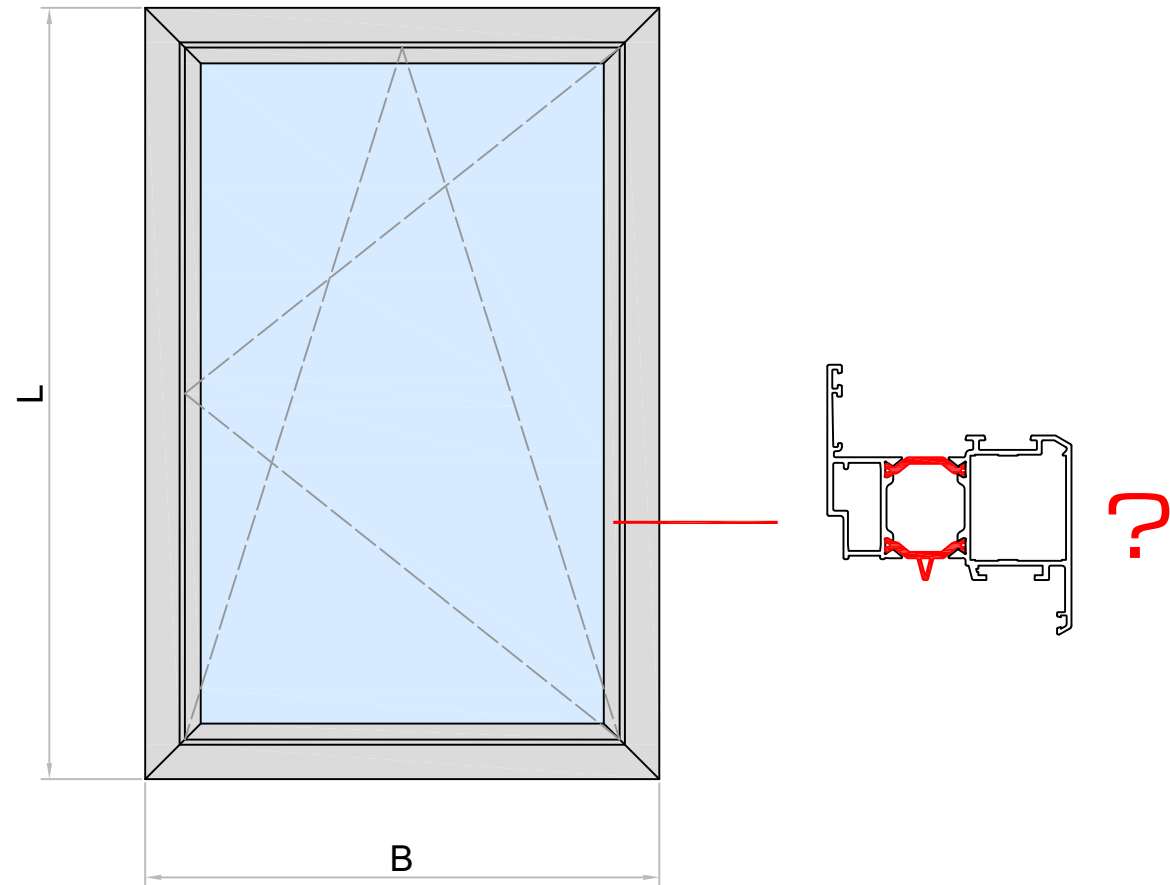

	1000	1100	1200	1300	1400	1500	1600	1700	1800	1900	2000	2100	2200	2300	2400	2500	2600	2700	2800	2900	3000
P-02-400	9,55	10,31	11,19	11,93	12,72	13,36	14,11	14,70	15,35	15,85	16,43	16,90	17,38	17,76	18,21	18,71	18,93	19,28	19,55	19,86	20,10
P-02-430	10,62	11,47	12,45	13,27	14,15	14,86	15,70	16,35	17,07	17,63	18,28	18,79	19,33	19,75	20,25	20,81	21,05	21,45	21,75	22,09	22,36

Toepassingsbereik
 Limites d' utilisations
 Scope



-   P-02-200
-   P-02-201
-   P-02-202

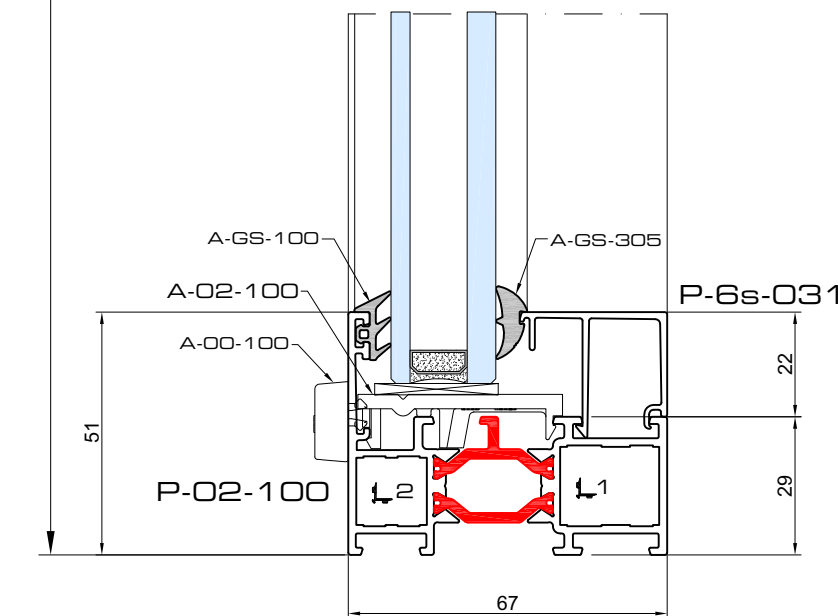
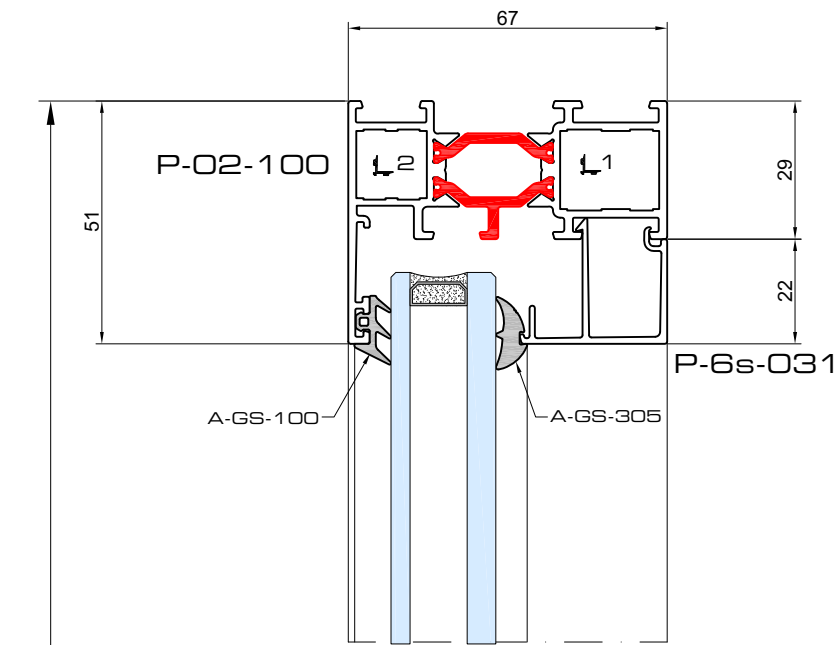

		B	#	H	#
P-02-100		B	2	H	2
P-6s-031		B - 58	2	H - 102	2

	max. 900
A-00-100	
A-00-105	4
A-02-100	4

	P	S	#
1	A-PH-1621	A-SH-1621	2
2	A-PH-1415	A-SH-1415	2

A-GS-100	2B + 2H
A-GS-305	2B + 2H

	B	H
	B - 72	H - 72

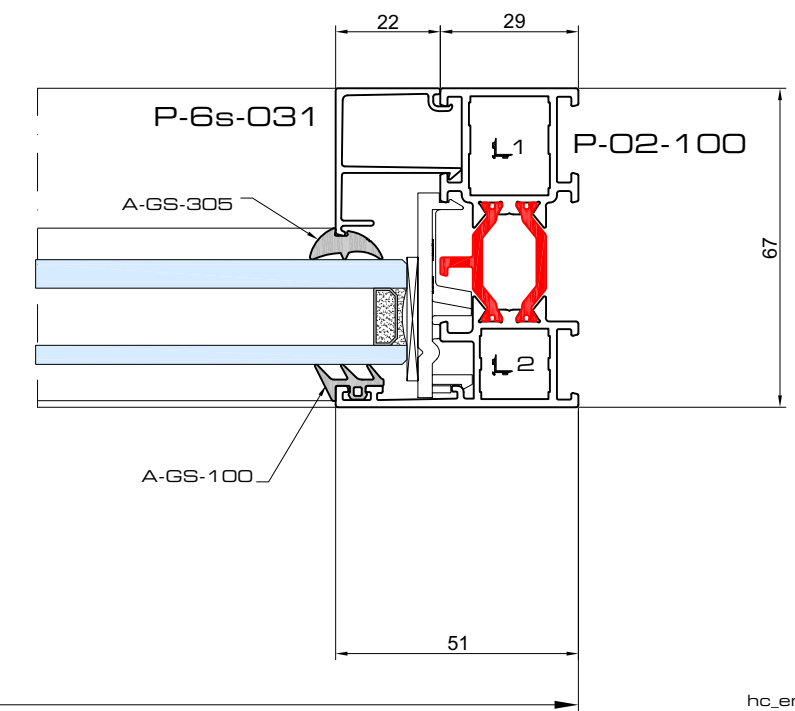
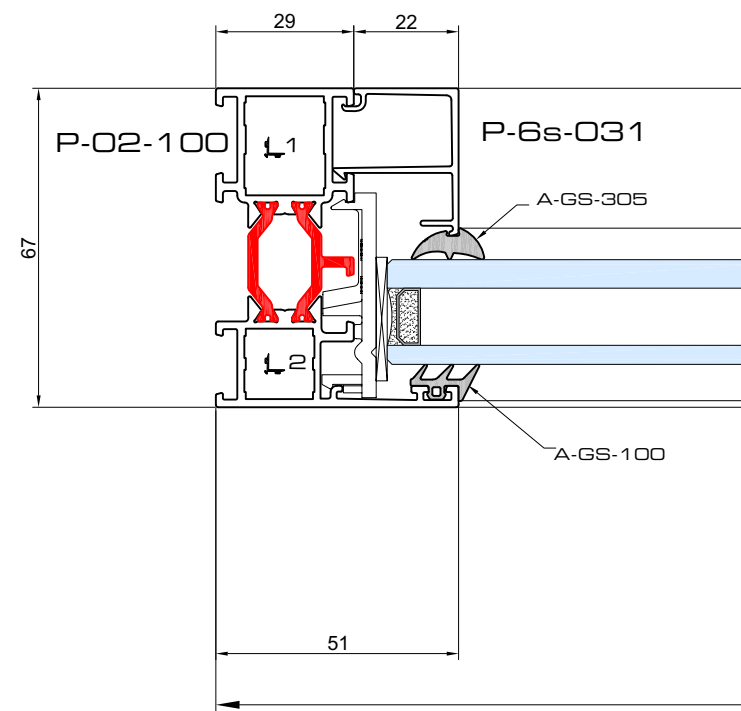
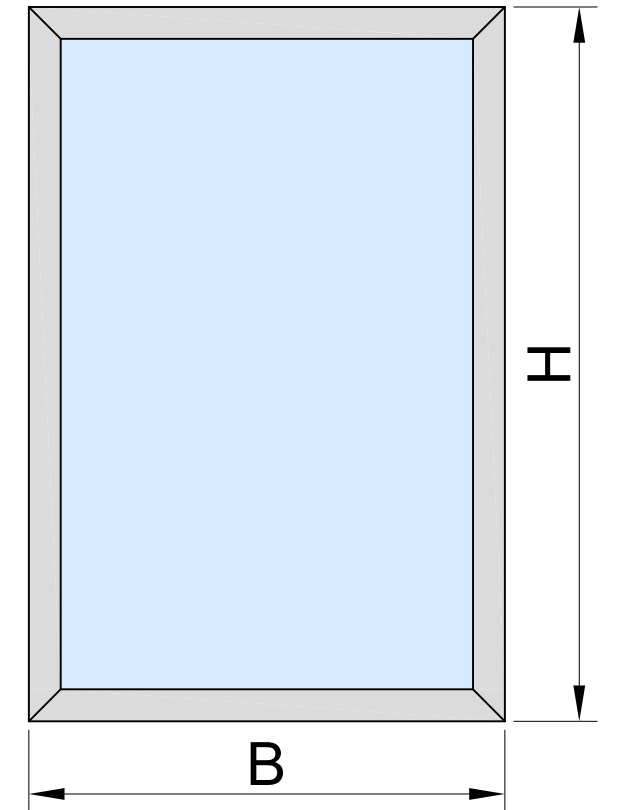

hc_enkel

		B	#	H	#
P-02-100		B	2	H	2
P-6s-031		B1 - 43.5	2	H - 102	2
P-6s-031		B2 - 43.5	2	H - 102	2
P-02-305		-	-	H - 4	1

A-00-100		max. 900
A-00-105		4
A-02-100		8
A-01-305		1

				#
1	A-PH-1621	A-SH-1621	-	4
2	A-PH-1415	A-SH-1415	-	4
3	-	-	A-TV-001	2
4	-	-	A-TV-064	2

A-GS-100	2B + 2H
A-GS-305	2B + 2H

	B	H
	B1 - 57.5	H - 72
	B2 - 57.5	H - 72

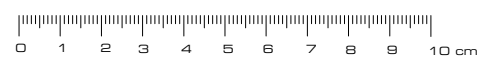
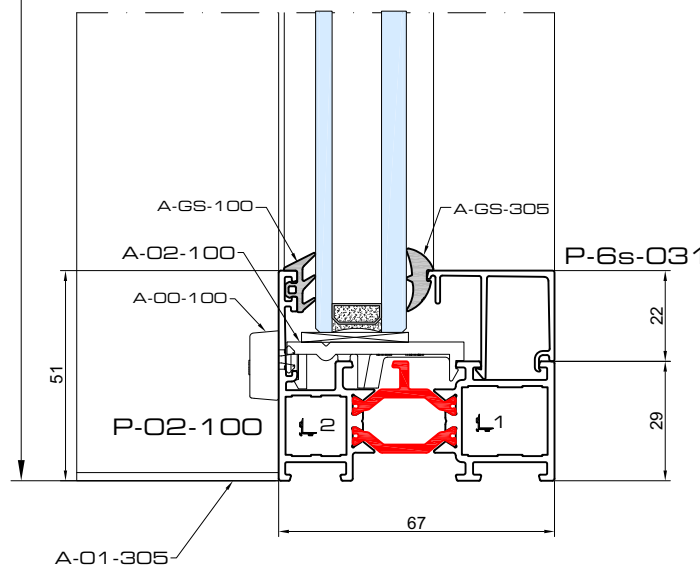
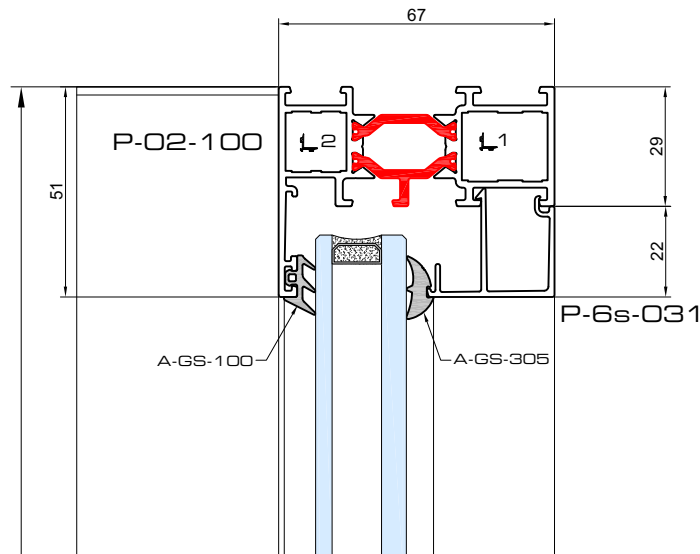
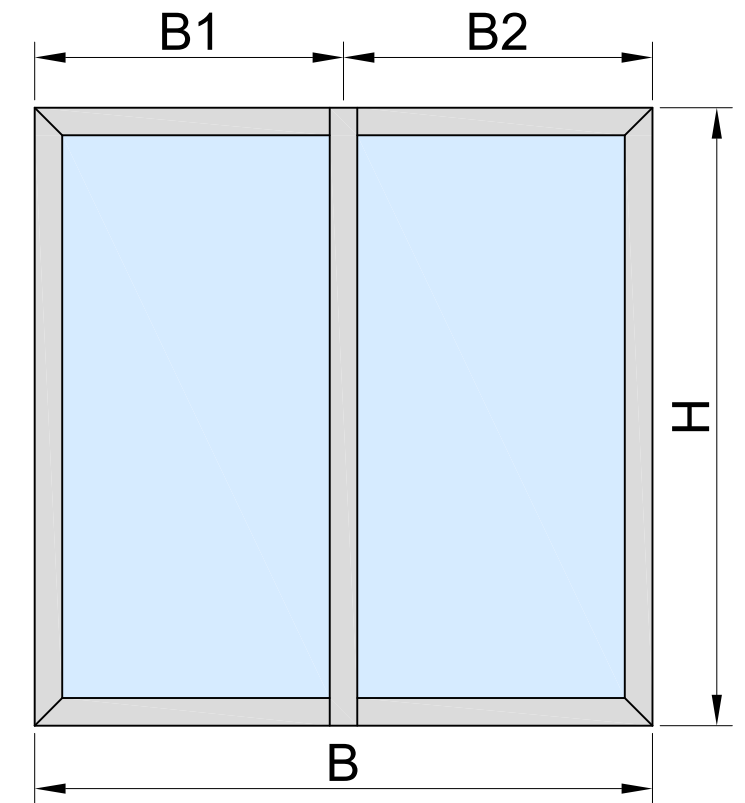

hc_dubbel_vast-305

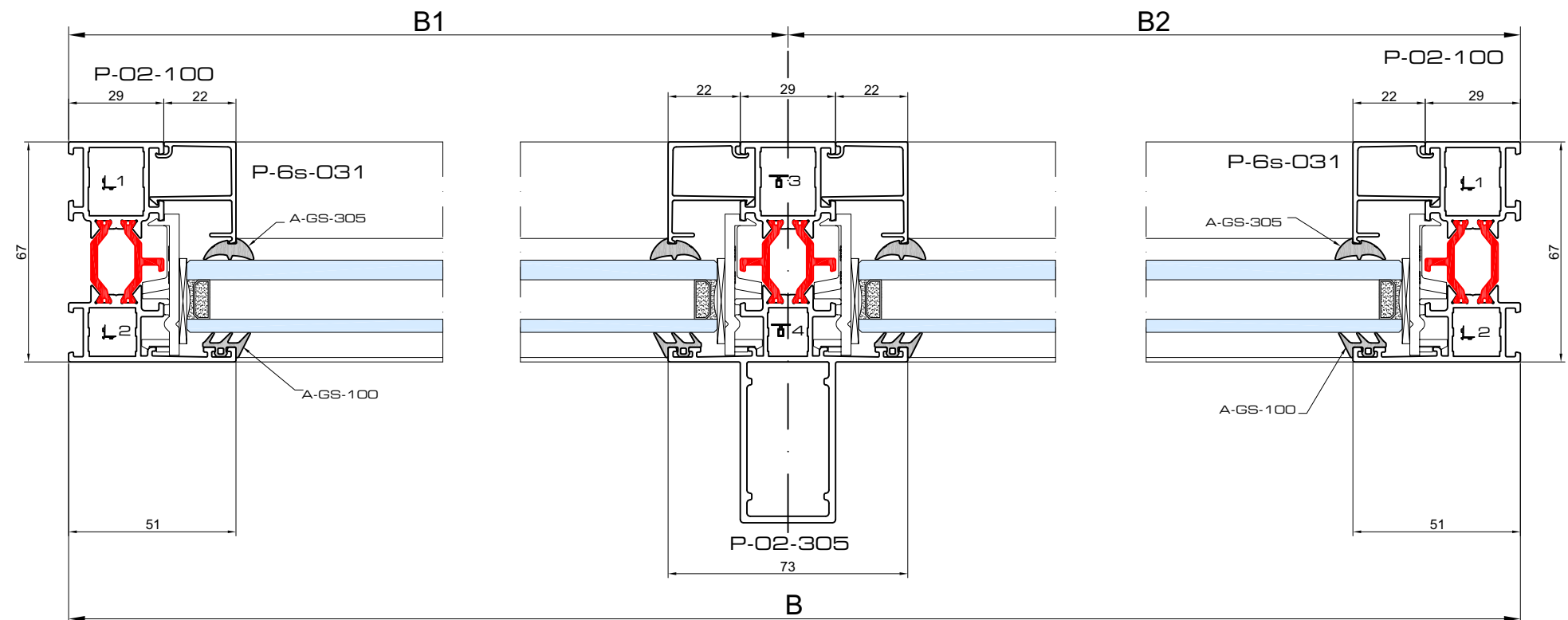

		B	#	H	#
P-02-100		B	2	H	2
P-6s-031		B1 - 51,5	2	H - 102	2
P-6s-031		B2 - 51,5	2	H - 102	2
P-02-306		-	-	H - 4	1

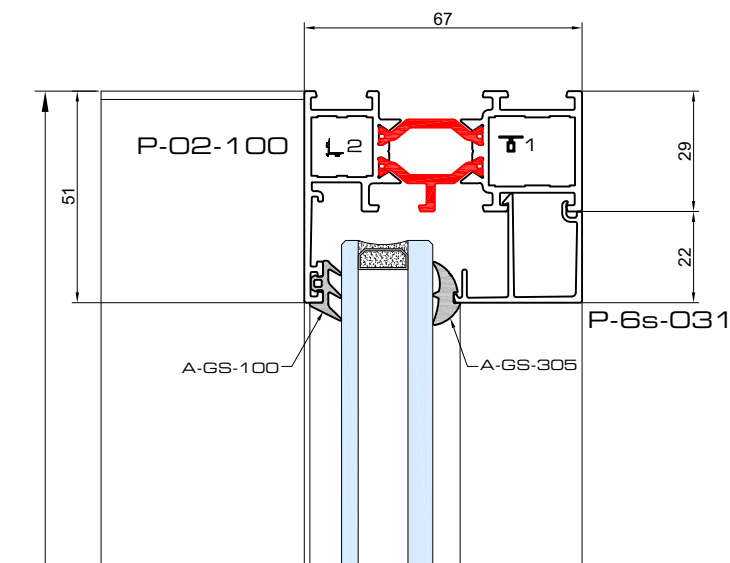
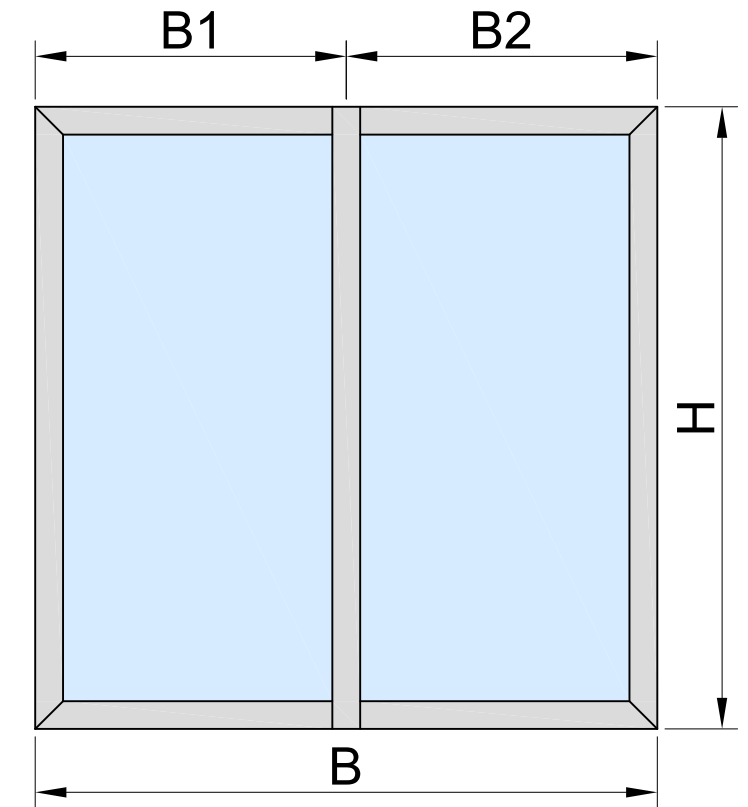

A-00-100		max. 900
A-00-105		4
A-02-100		8
A-02-306		1

				#
1	A-PH-1621	A-SH-1621	-	4
2	A-PH-1415	A-SH-1415	-	4
3	-	-	A-TV-002	2
4	-	-	A-TV-065	2

A-GS-100	2B + 2H
A-GS-305	2B + 2H

	B	H
	B1 - 65,5	H - 72
	B2 - 65,5	H - 72

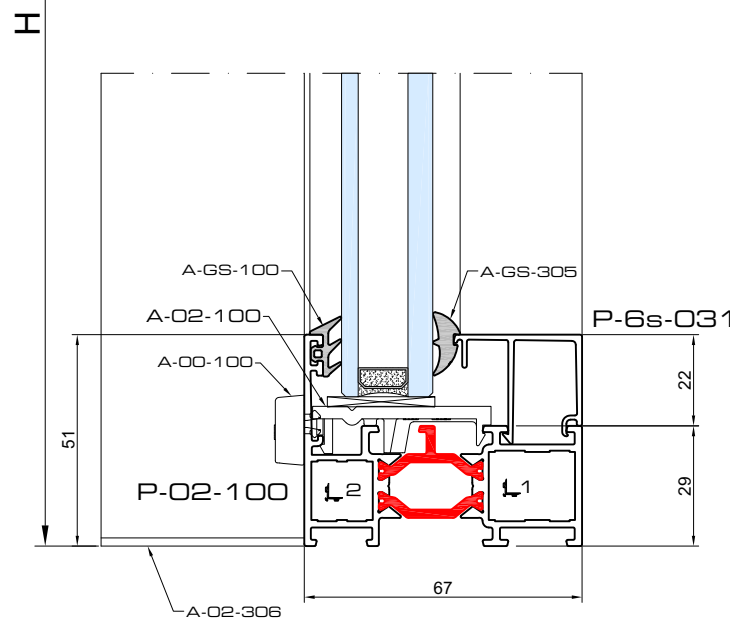

hc_dubbel_vast_306

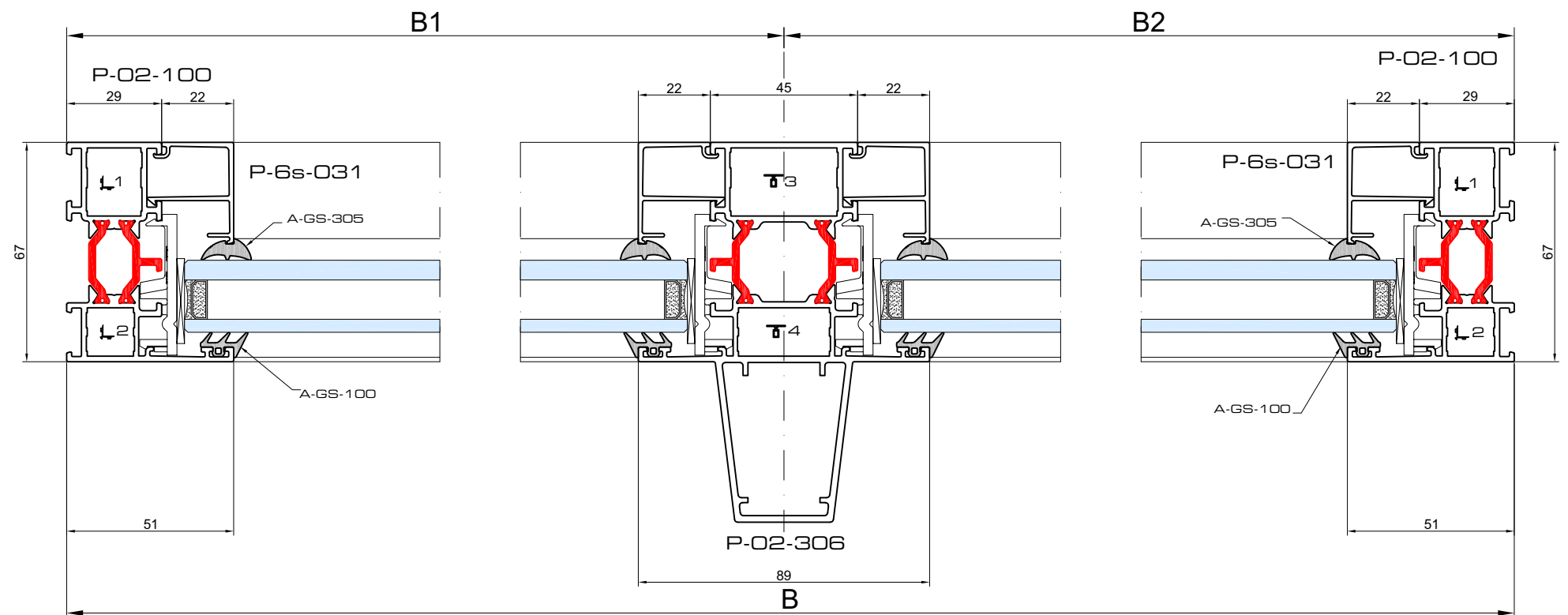

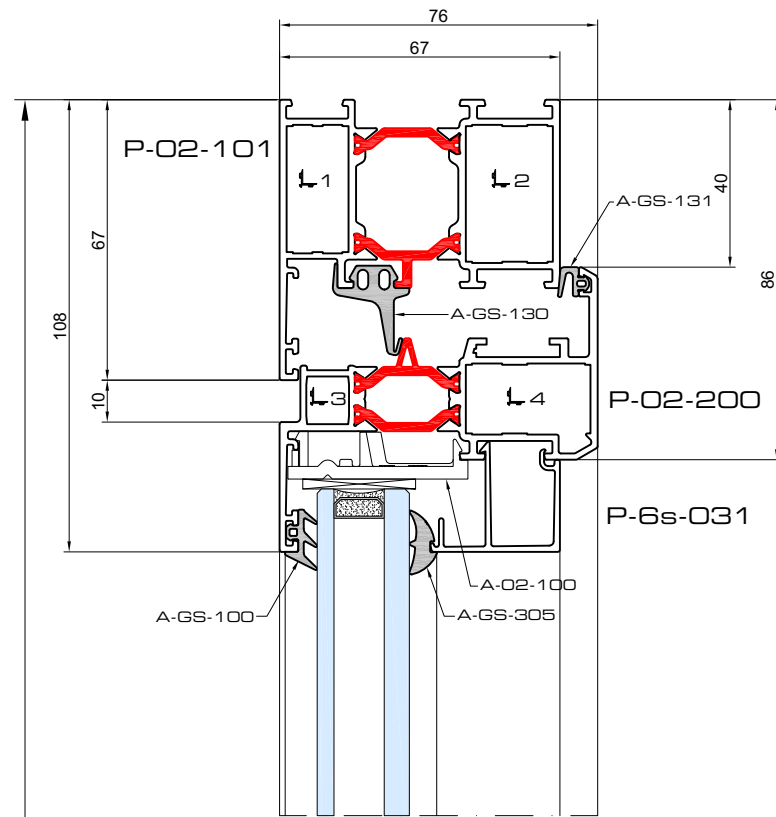

		B	#	H	#
P-02-101		B	2	H	2
P-02-200		B - 80	2	H - 80	2
P-6s-031		B - 172	2	H - 216	2
P-00-702		B - 160	1	-	-

A-00-100			#
A-00-105	8		
A-02-100	8		
A-00-700	= B/250		
A-00-702	1		

			#
1	A-PH-3015	A-SH-3015	4
2	A-PH-3221	A-SH-3221	4
3	A-PH-1110	A-SH-1110	4
4	A-PH-1630	A-SH-1630	4

	B	H
A-GS-130	2B + 2H	
A-GS-131	2B + 2H	
A-GS-100	2B + 2H	
A-GS-305	2B + 2H	

	B	H
	B - 186	H - 186

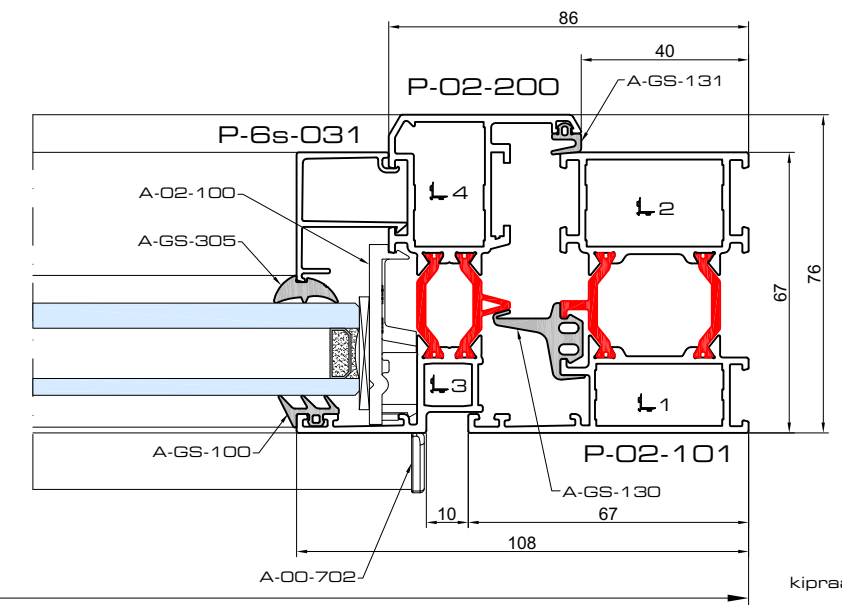
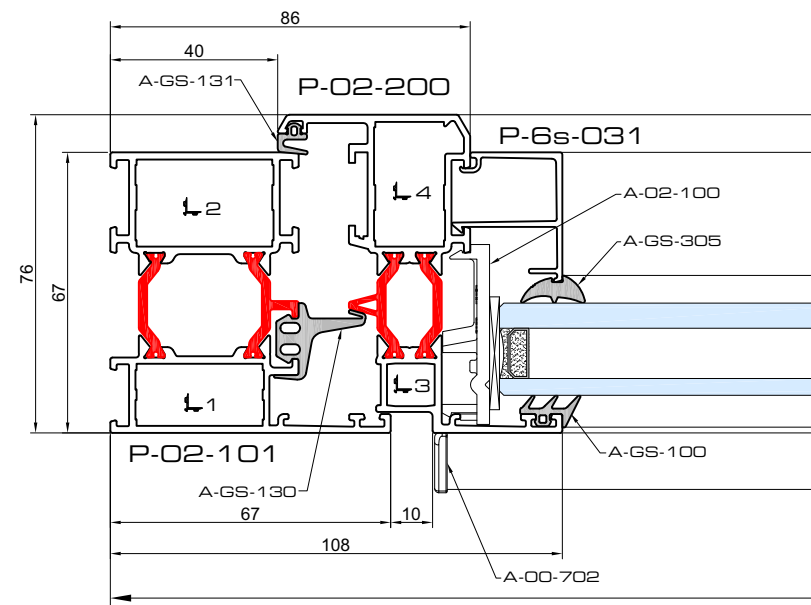
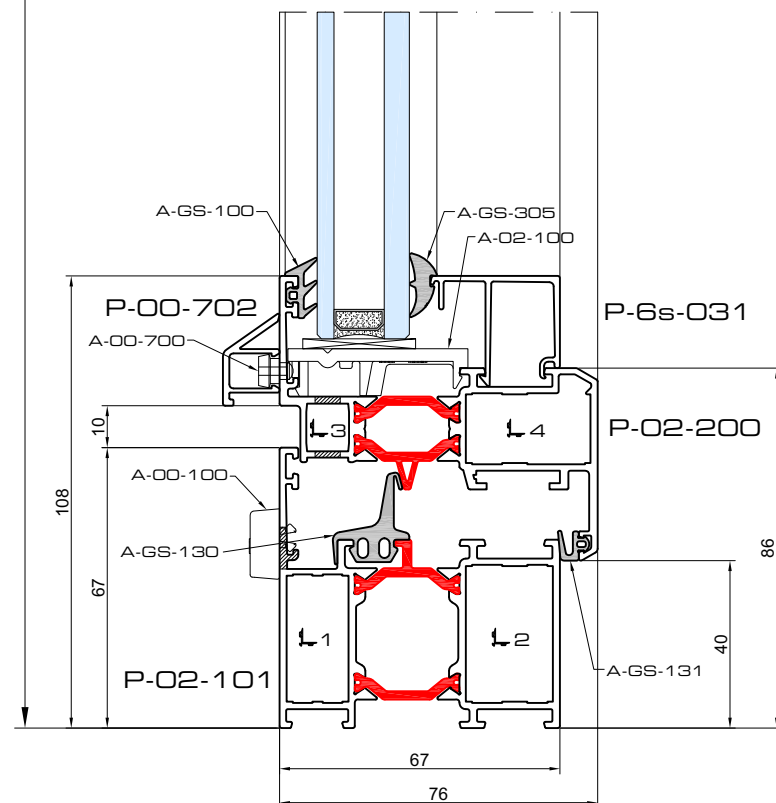
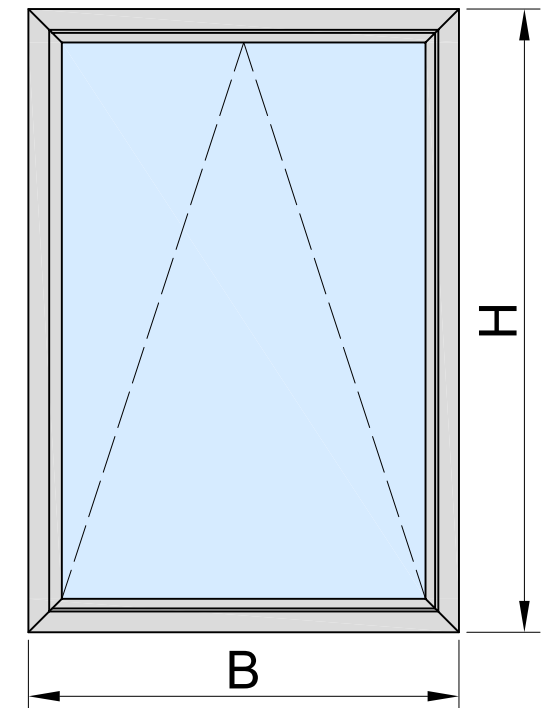

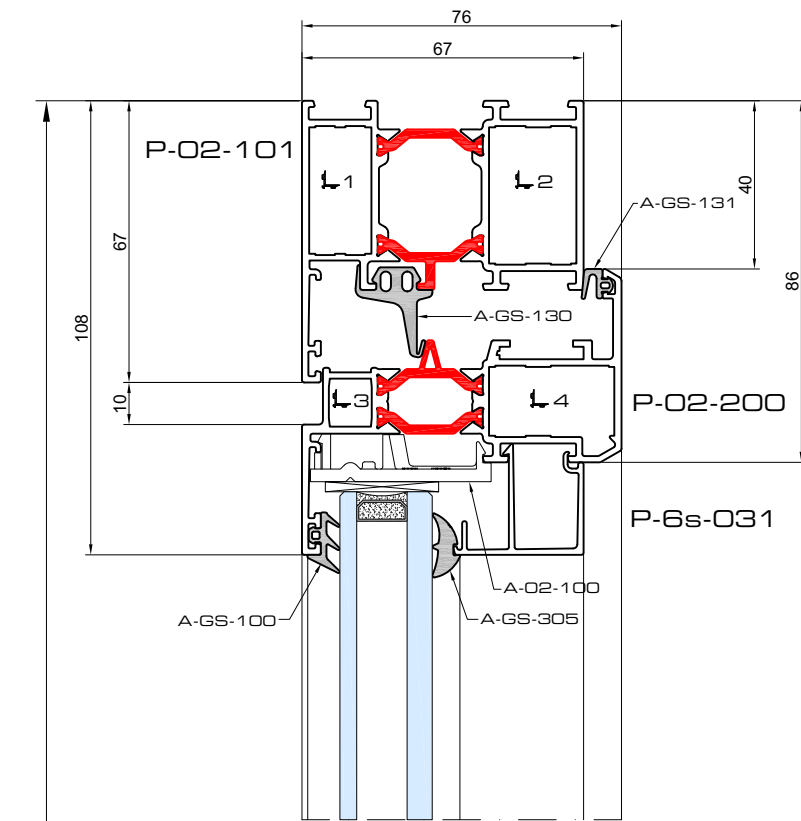

		B	#	H	#
P-02-101		B	2	H	2
P-02-200		B - 80	2	H - 80	2
P-6s-031		B - 172	2	H - 216	2
P-00-702		B - 160	1	-	-

A-00-100	max. 900
A-00-105	8
A-02-100	6
A-00-700	= B/250
A-00-702	1

	P	S	#
1	A-PH-3015	A-SH-3015	4
2	A-PH-3221	A-SH-3221	4
3	A-PH-1110	A-SH-1110	4
4	A-PH-1630	A-SH-1630	4

A-GS-130	2B + 2H
A-GS-131	2B + 2H
A-GS-100	2B + 2H
A-GS-305	2B + 2H

	B	H
	B - 186	H - 186

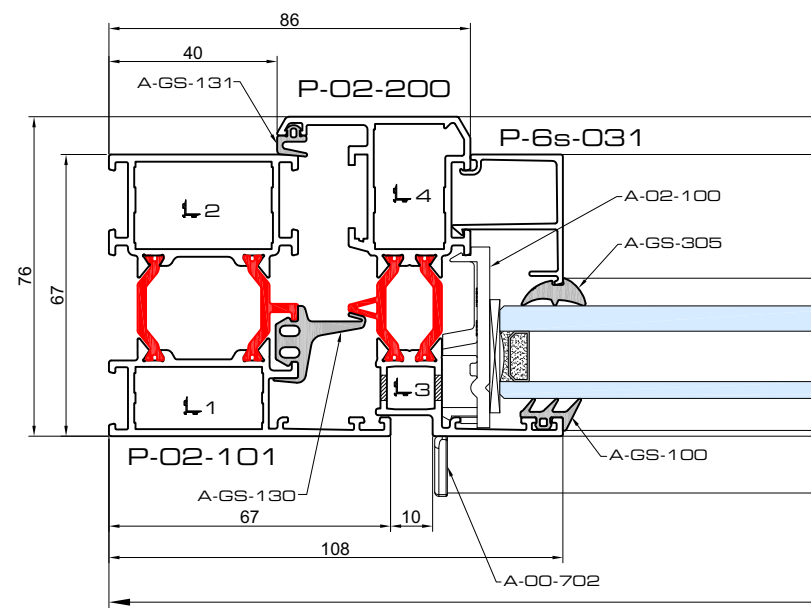
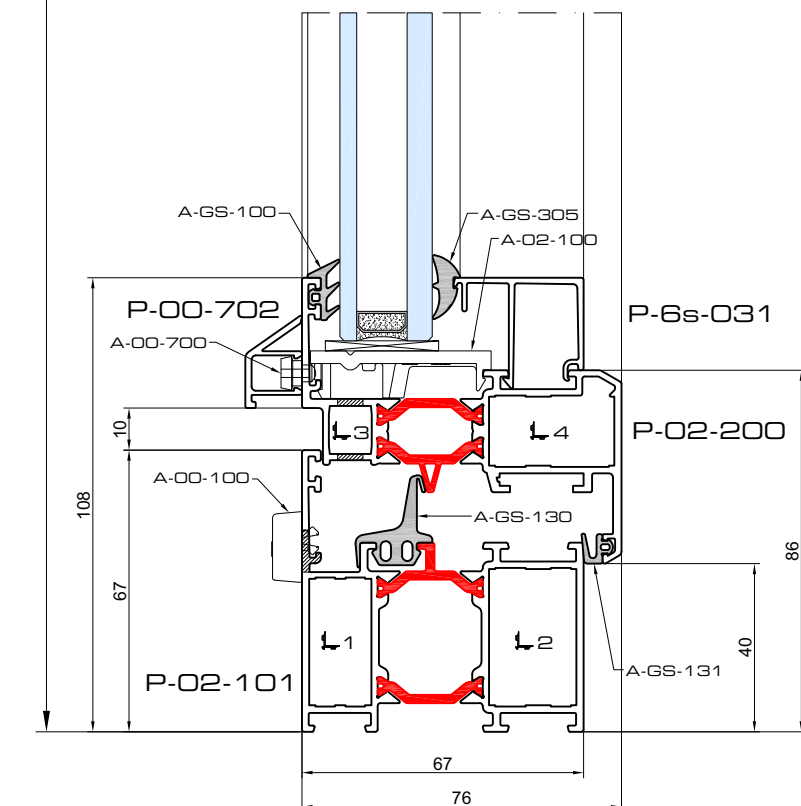
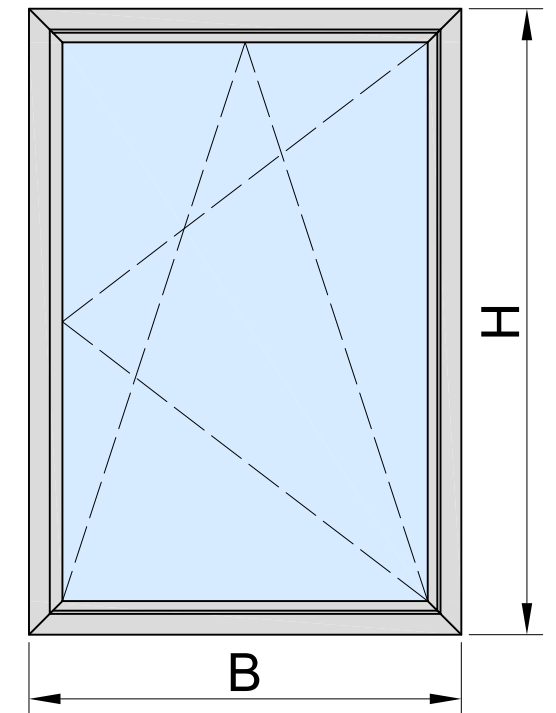

B

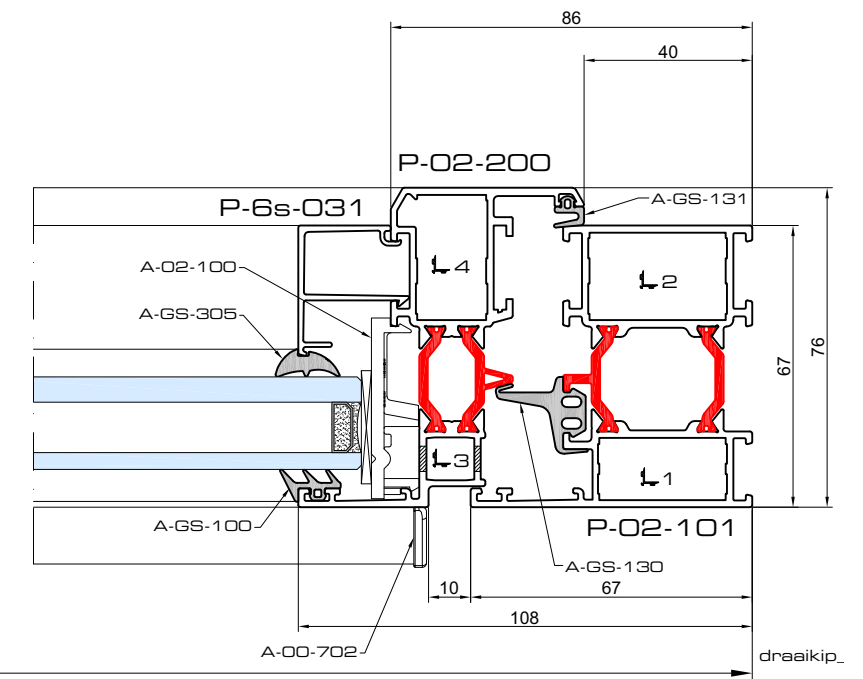

draaikip

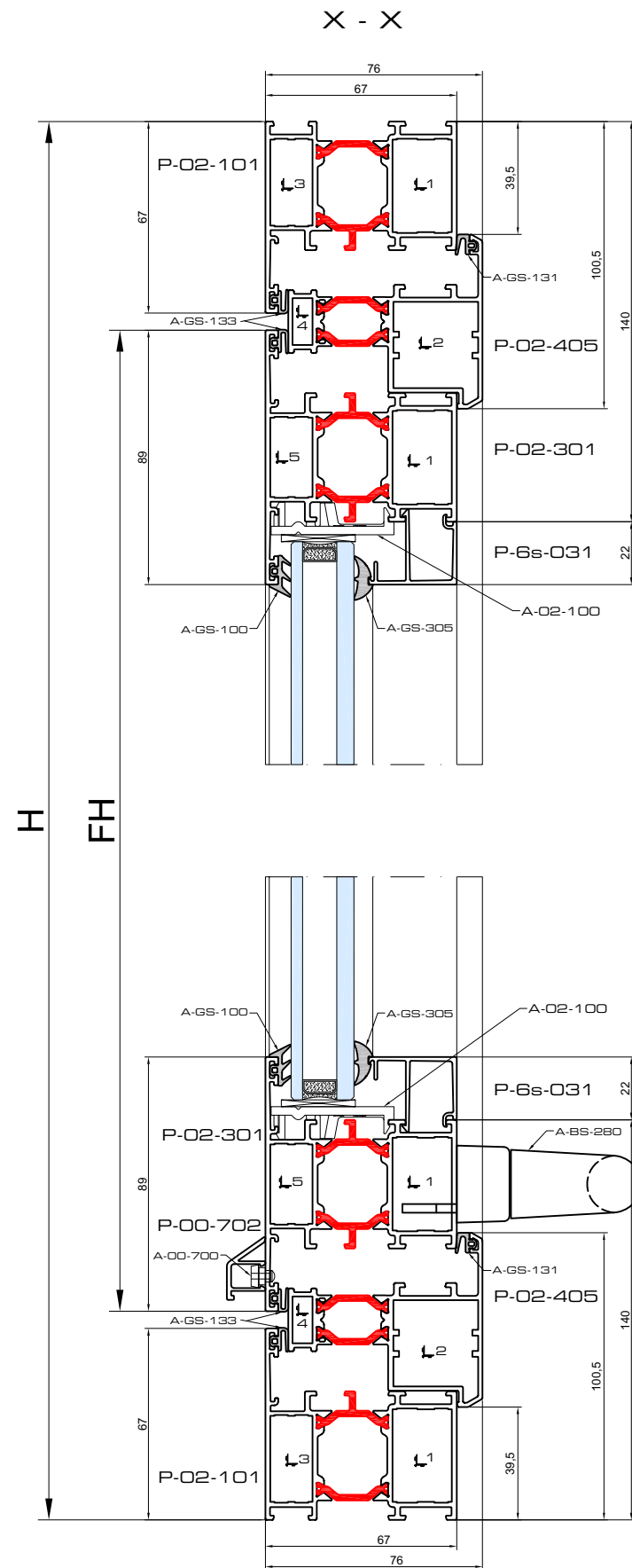

		B	#	H	#
P-02-100		B	2	H	2
P-02-301		B-146	2	H-146	2
P-02-405		B-79	2	-	-
P-02-405		-	-	(H-79) / 2	2
P-6s-031		B - 280	2	H - 324	2
P-00-602		B - 408	1	-	-
P-00-602		B/2 - 266.5	2	-	-
P-00-602		-	-	H/2 - 193	1
P-00-602		-	-	H/2 - 223.5	1
P-00-602		B/2 - 245	2	-	-
P-00-602		B/2 - 381.5	1	-	-
P-00-602		B/2 - 266.5	1	-	-
P-00-602		(B - 546) / 3	3	-	-
P-00-602		(B - 662) / 4	4	-	-
P-00-702		B - 153	1	-	-

A-00-100		max. 900
A-00-105		12
A-00-700		= B/250
A-00-702		2
A-02-100		8

	P	#	S	#
1	A-PH-3221	8	A-SH-3221	8
2	A-PH-3025	4	A-SH-3025	4
3	A-PH-3015	4	A-SH-3015	4
4	A-PH-1607	4		
5	A-PH-2715	4		

A-GS-100	2B + 2H
A-GS-305	2B + 2H
A-GS-131	2B + 2H
A-GS-133	4B + 4H

	B	H
	B - 294	H - 294

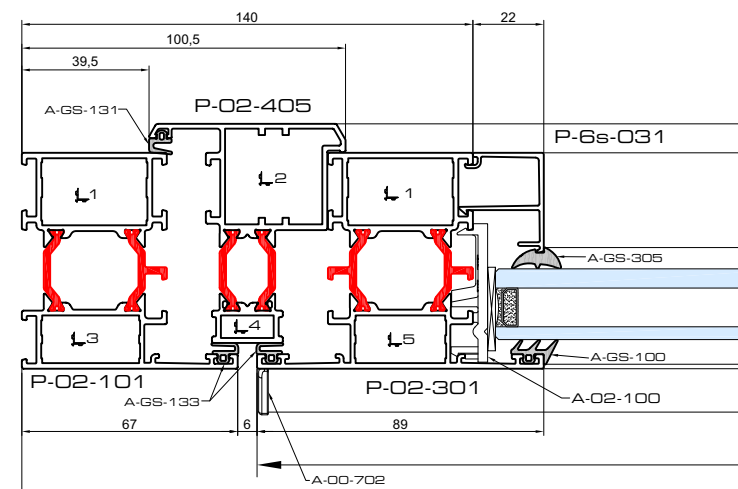

Y - Y

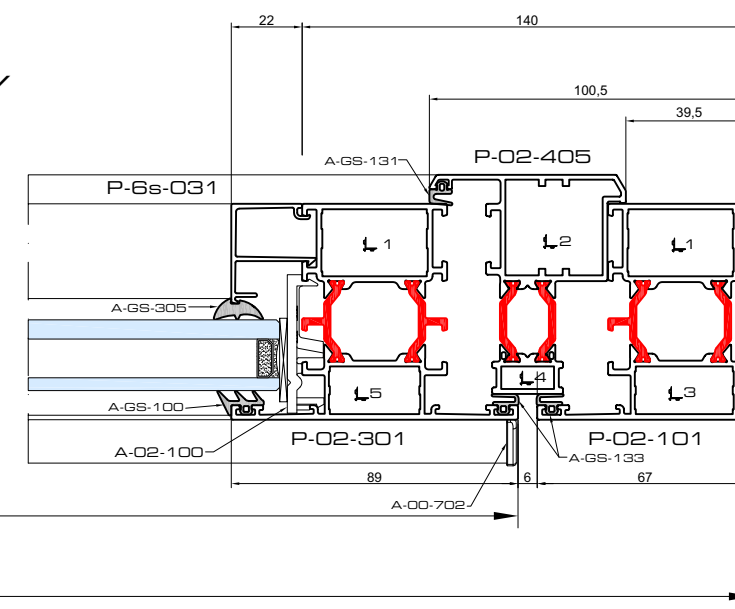

FB

B

FB = 500 - 1200

FB = 1200 - 1800

FB = 1800 - 2400

	#
A-BS-280	1
A-BS-282	1
A-BS-283	1
A-BS-283	2
A-BS-285L	1
A-BF-285R	1

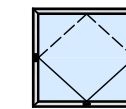

MAX. 180kg

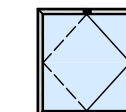

MAX. 120kg



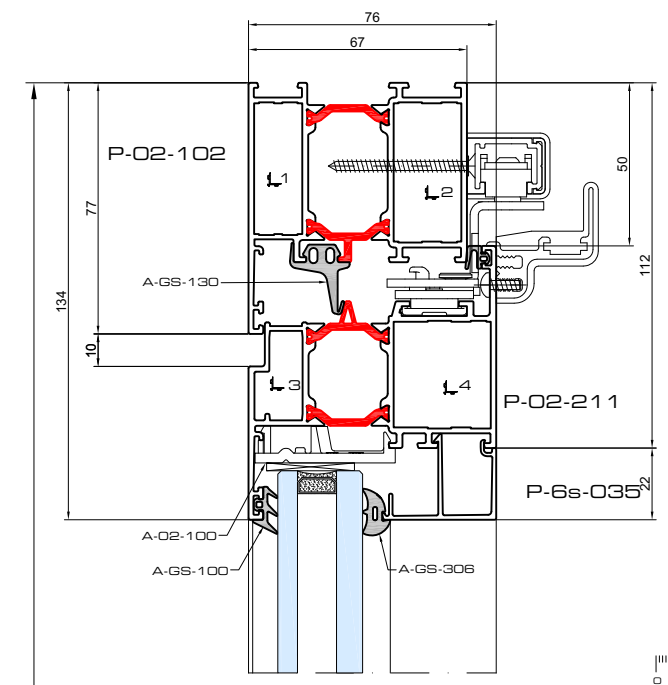

Bx	B _(max)	
650 - 930	1930	A-BS-300L A-BS-300R
931 - 1080	2230	A-BS-301L A-BS-301R
1081 - 1280	2630	A-BS-302L A-BS-302R
1281 - 1480	3030	A-BS-303L A-BS-303R
1481 - 1680	3430	A-BS-304L A-BS-304R
1681 - 1880	3830	A-BS-305L A-BS-305R

		B	#	H	#
P-02-102		B	2	H	2
P-02-211		B1 - 67.5	2	H - 100	2
P-02-301		-	-	H - 224	1
P-6s-035		B1 - 191.5	2	H - 268	2
P-6s-027		B2 - 77.5	2	H - 154	2

A-00-100		max. 900
A-00-105		8
A-00-106		4
A-02-100		12

1	A-PH-4015	A-SH-4015	-
2	A-PH-4221	A-SH-4221	-
3	A-PH-2710	A-SH-2710	-
4	A-PH-3230	A-SH-3230	-
5	-	-	A-TV-002
6	-	-	A-TV-065

A-GS-100	4B + 4H
A-GS-131	2B1 + 2H
A-GS-130	2B1 + 2H
A-GS-305	2B + 2H
A-GS-306	2B + 2H

	B	H
	B1 - 205.5	H - 268
	B2 - 91.5	H - 154

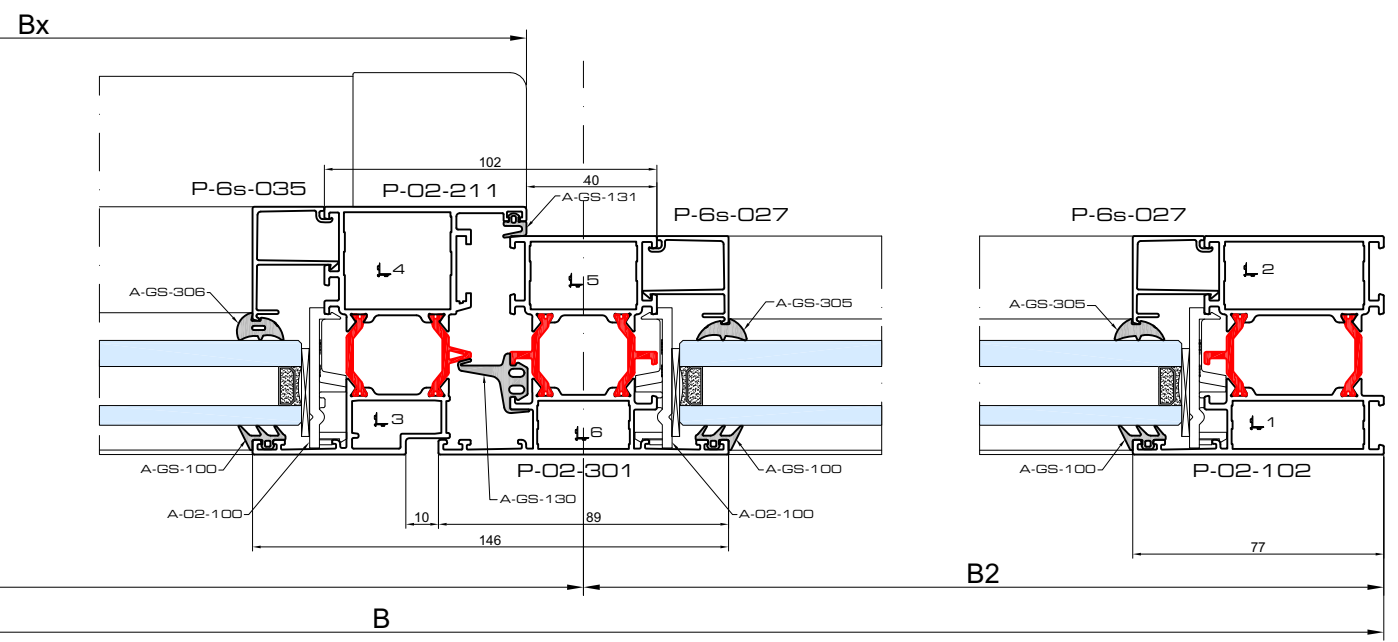
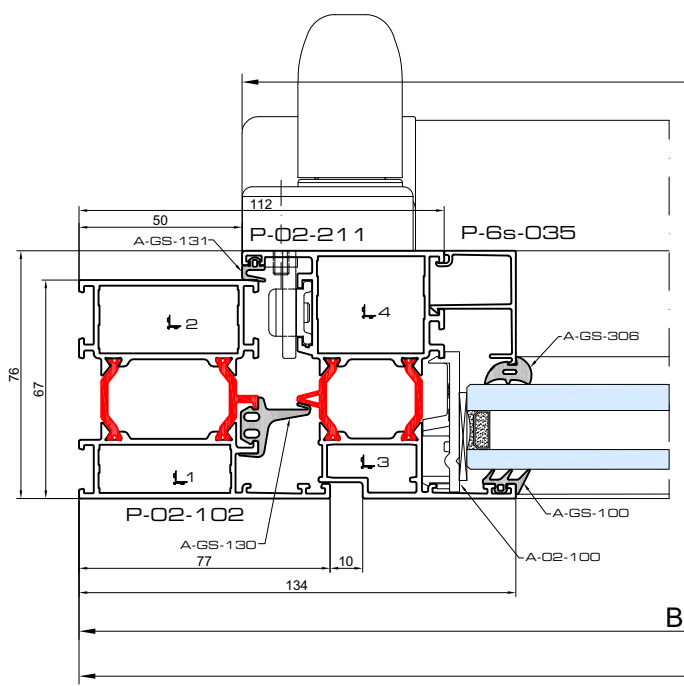
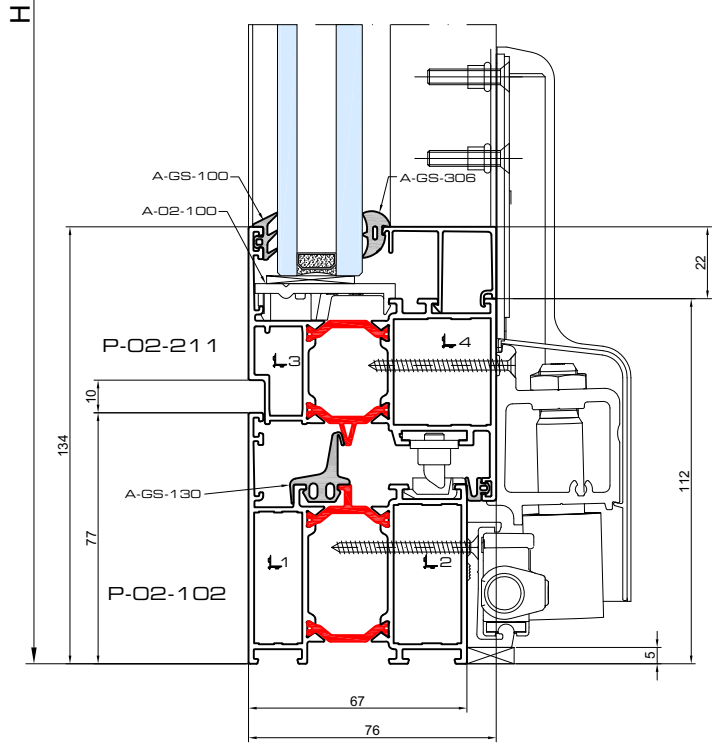
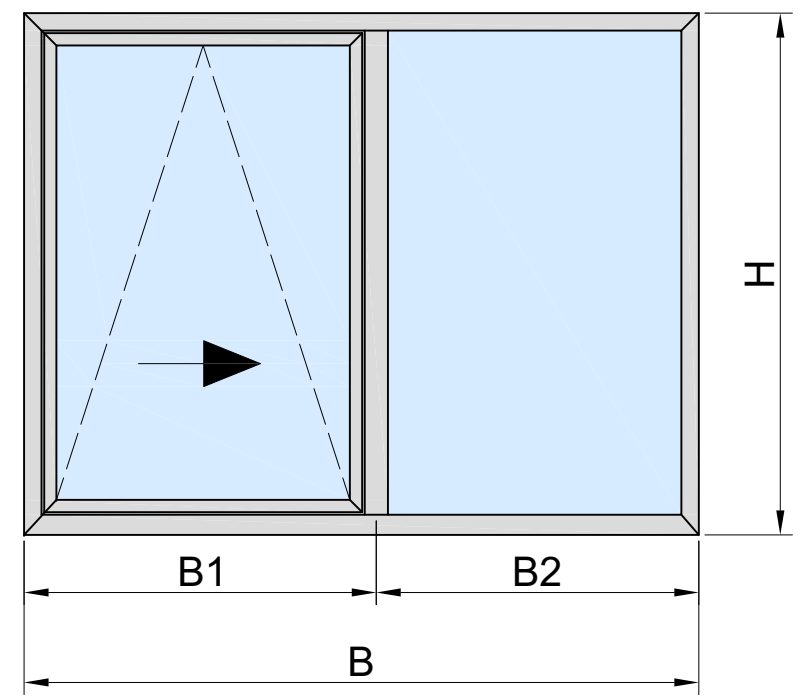

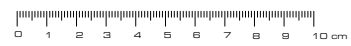
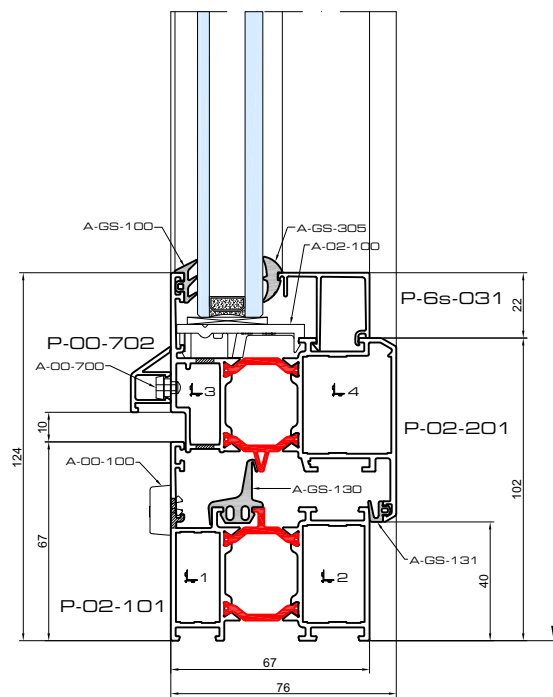
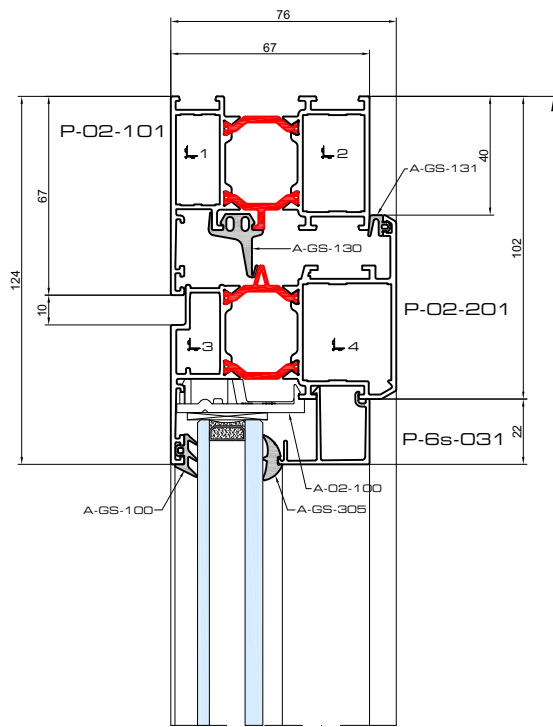

		B	#	H	#
P-02-101		B	2	H	2
P-02-201		$(B - 85) / 2$	4	H - 80	4
P-02-400		-	-	H - 158	1
P-6s-031		$B - 333 / 2$	4	H - 248	4
P-00-702		$B - 245 / 2$	2	-	-

A-00-100		max. 900
A-00-105		12
A-02-100		8
A-00-700		= B/250
A-00-702		2
A-02-200		1

	P	S	#
1	A-PH-3015	A-SH-3015	4
2	A-PH-3221	A-SH-3221	4
3	A-PH-2710	A-SH-2710	8
4	A-PH-3230	A-SH-3230	8

A-GS-130	2B + 3H
A-GS-131	2B + 3H
A-GS-100	2B + 4H
A-GS-305	2B + 4H

	B	H
	$(B - 361) / 2$	H - 218
	$(B - 361) / 2$	H - 218

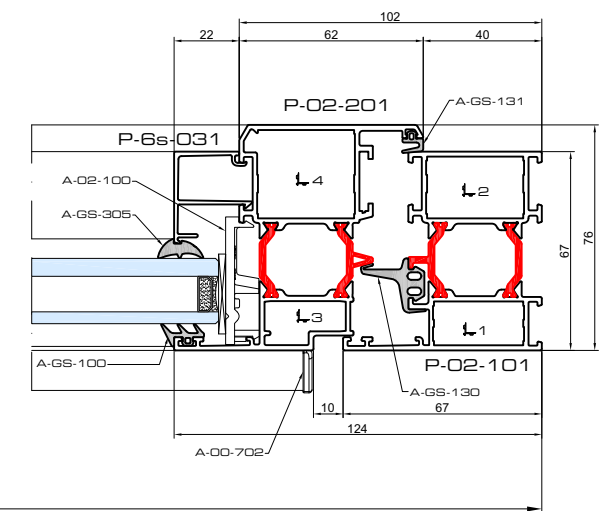
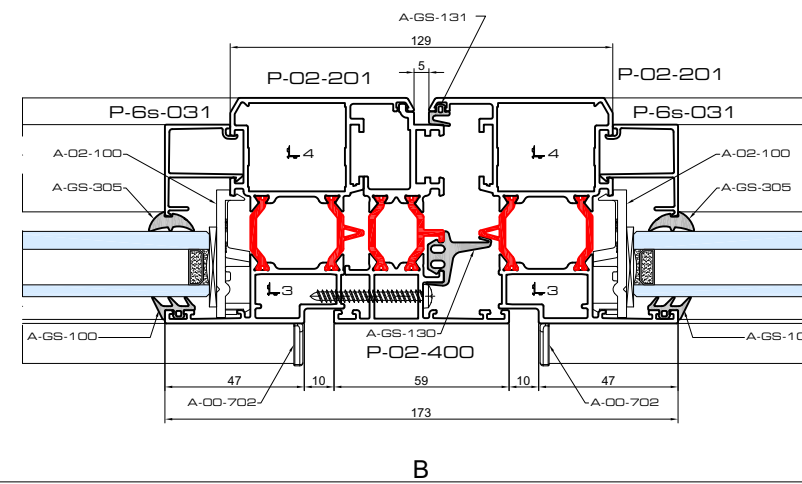
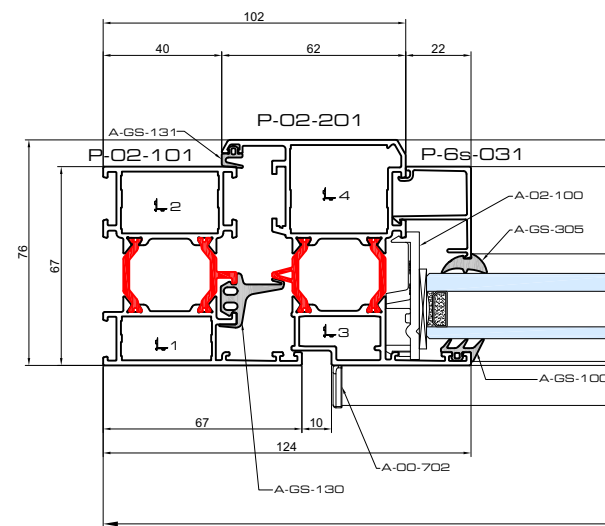
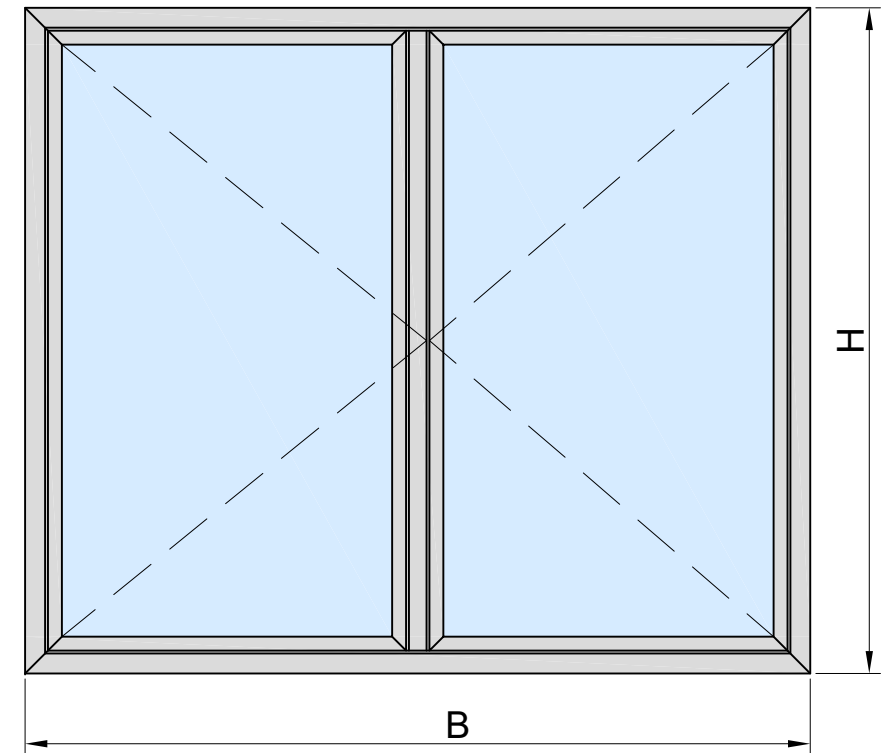

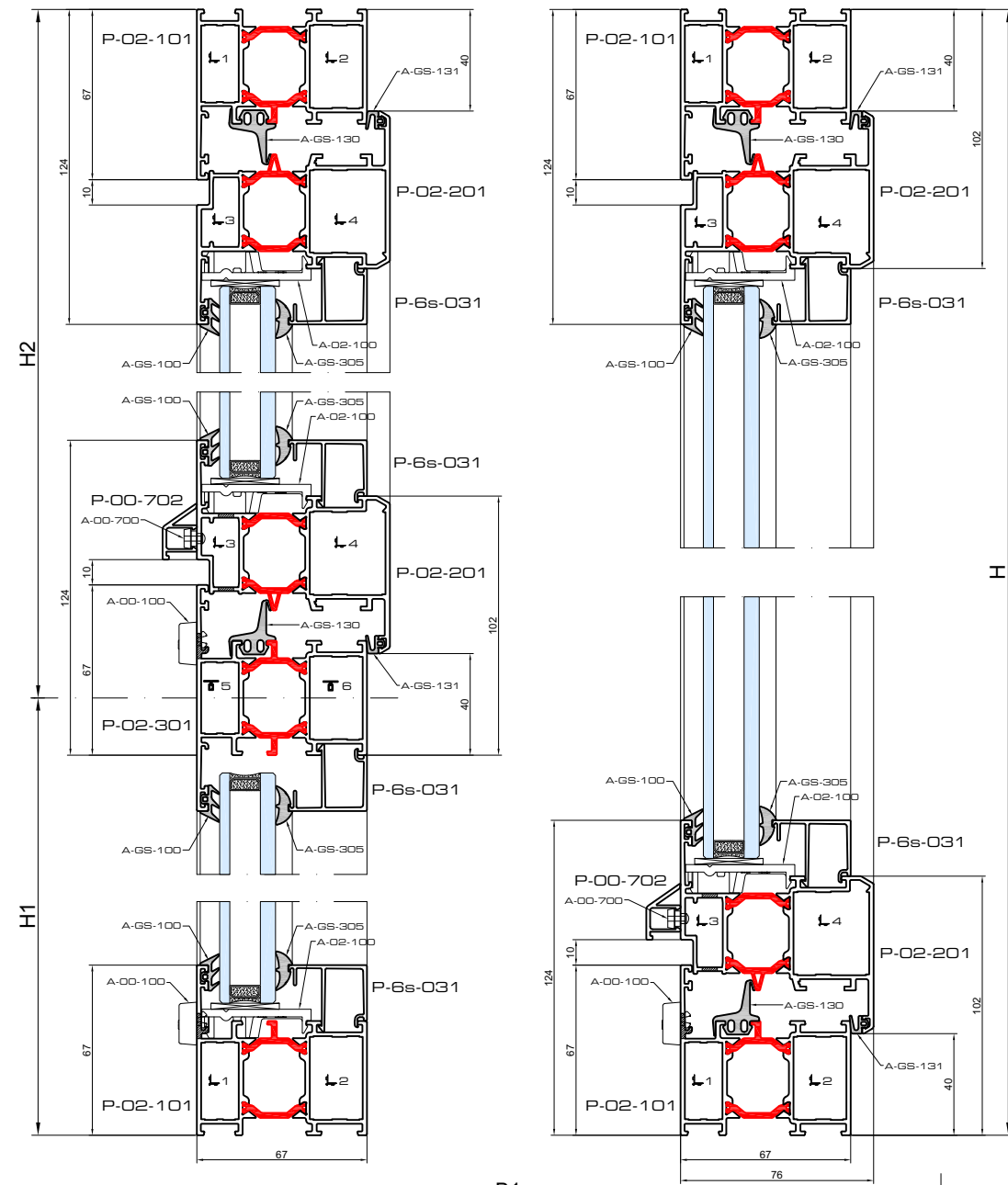

		B	#	H	#
P-02-101		B	2	H	2
P-02-201		B1 - 57.5	2	H2 - 57.5	2
		(B2-57.5)/2 - 2.5	4	H - 80	4
P-02-400		-	-	H - 158	1
P-02-306		-	-	H - 4	1
P-02-301		B1 - 67.5	1	-	-
P-6s-031		B1 - 67.5	2	H1 - 111.5	2
		B1 - 181.5	2	H2 - 225.5	2
		(B2 - 57.5)/2 - 126.5	4	H - 248	4
P-00-702		B1 - 137.5	1	-	-
		(B2 - 57.5)/2 - 82.5	2	-	-

A-00-100		max. 900	A-GS-130	2B2 + 3H
A-00-105	16		A-GS-131	2(B1 + H2)
A-00-106	8		A-GS-131	2B2 + 3H
A-02-100	20		A-GS-100	2(B1 + H2)
A-00-700	= B/250		A-GS-100	2B2 + 4H
A-00-702	3		A-GS-305	2(B1 + H2)
A-02-200	1		A-GS-305	2B2 + 4H
A-02-306	2		A-GS-305	2(B1 + H2)

1	A-PH-3015	A-SH-3015	-
2	A-PH-3221	A-SH-3221	-
3	A-PH-2710	A-SH-2710	-
4	A-PH-3230	A-SH-3230	-
5	-	-	A-TV-002
6	-	-	A-TV-065

	B	H
	B1 - 82	H1 - 82
	B1 - 196	H2 - 196
	(B2 - 57.5)/2 - 141	H - 218

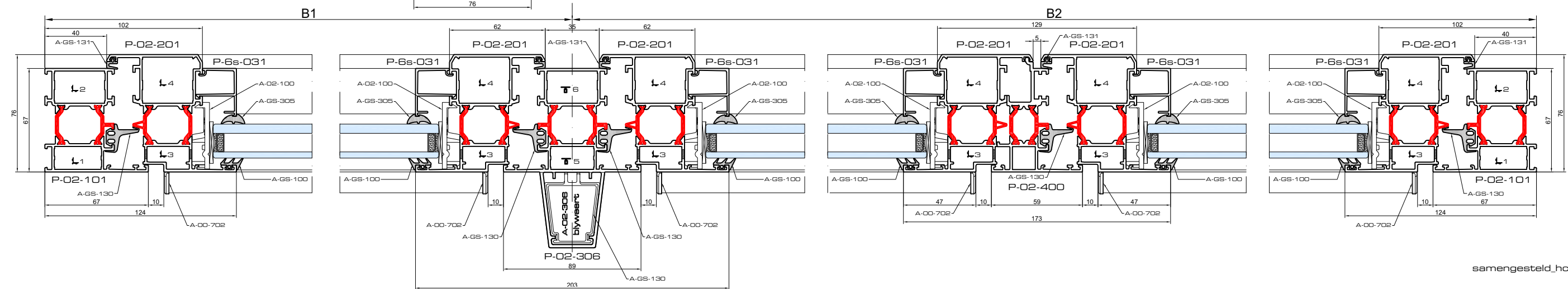
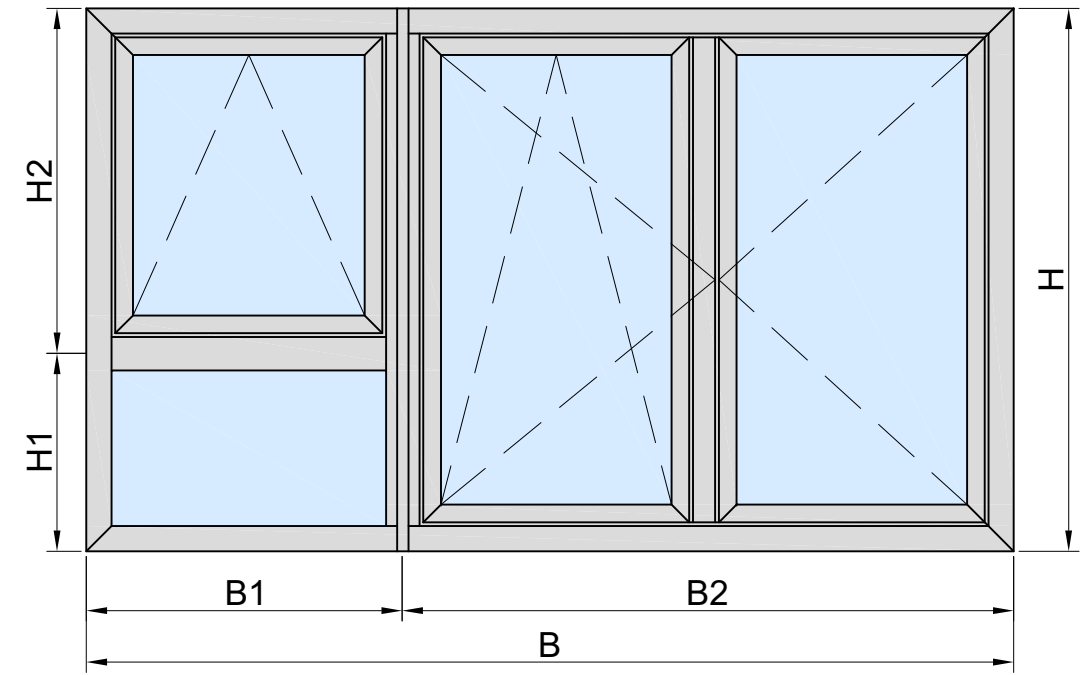

samengesteld_hc

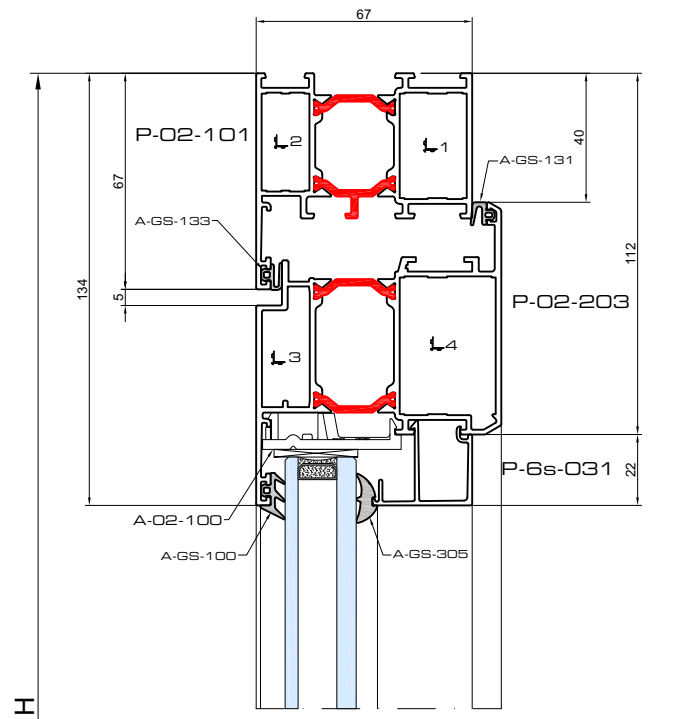

		B	#	H	#
P-02-101		B	1	-	-
P-02-101		-	-	H	1
P-02-203		B - 80	2	▲ H - 47	2
				◆ H - 49	2
▲ P-02-900		B - 94	1	-	-
▲ P-00-500		B - 94	1	-	-
▲ P-00-203		B - 126	1	-	-
◆ P-00-204		B - 126	1	-	-
P-6s-031		B - 224	2	▲ H - 235	2
				◆ H - 237	2
▲ A-00-204,5,6,7,8		B - 123	1	-	-

	#
A-00-105	6
A-02-100	4
▲ A-02-204	1
◆ A-02-900	1

			#
1	A-PH-3221	A-SH-3221	2
2	A-PH-3015	A-SH-3015	2
3	A-PH-3706		4
4	A-PH-4230	A-SH-4230	4

	#
A-BS-254	1
A-BS-255	1
A-BS-242	1
A-BS-250	1
A-BS-251	2
A-BF-063	3

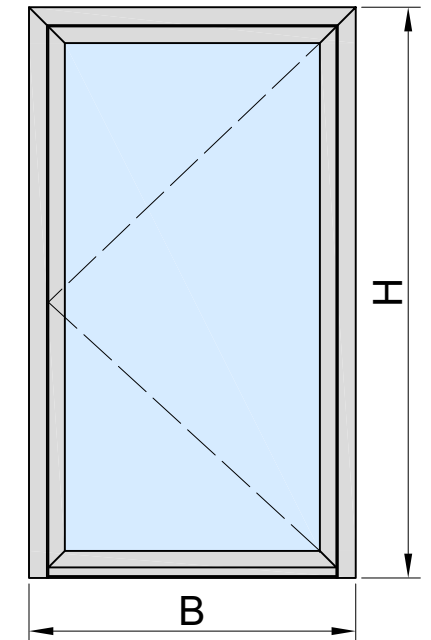

A-GS-131	2B + 2H
A-GS-133	B + 2H
A-GS-100	2B + 2H
A-GS-305	2B + 2H
▲ A-00-203	B - 126
◆ A-00-121	B - 126

	B	H
	B - 238	▲ H - 205
		◆ H - 207

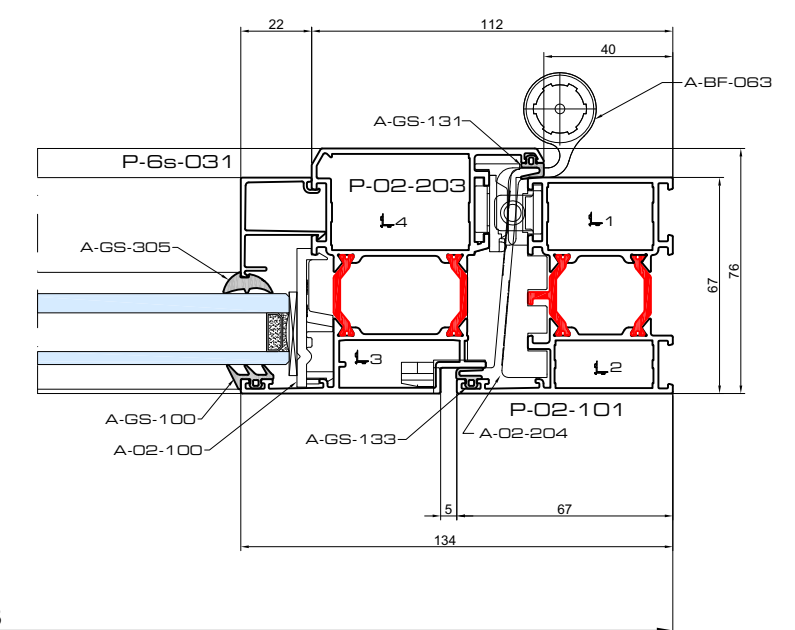
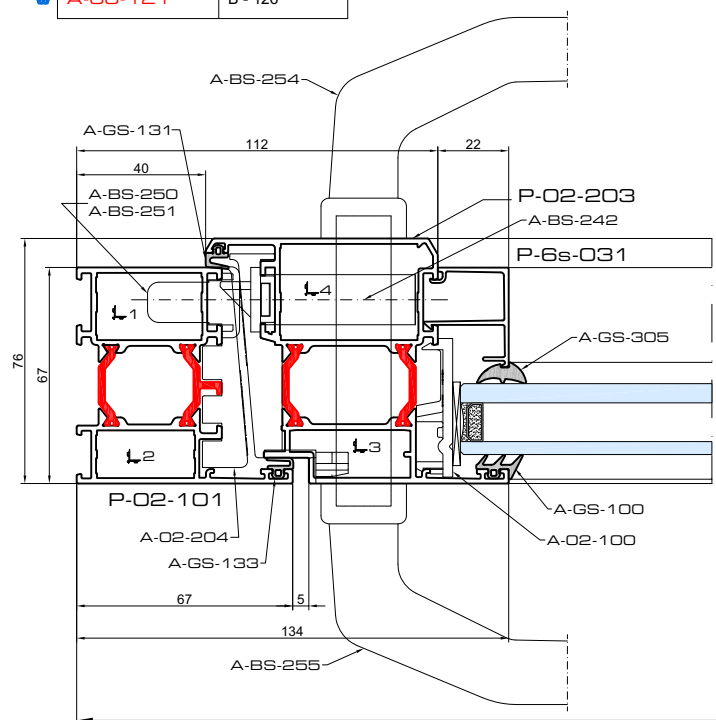
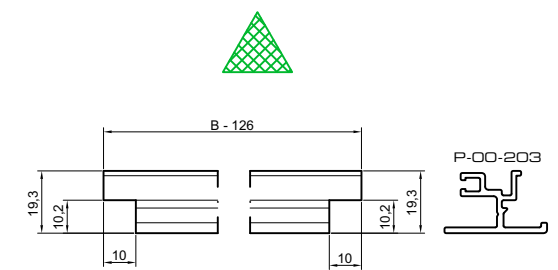
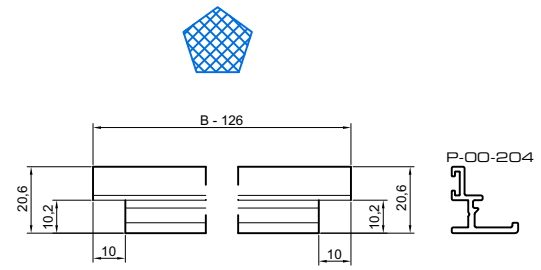
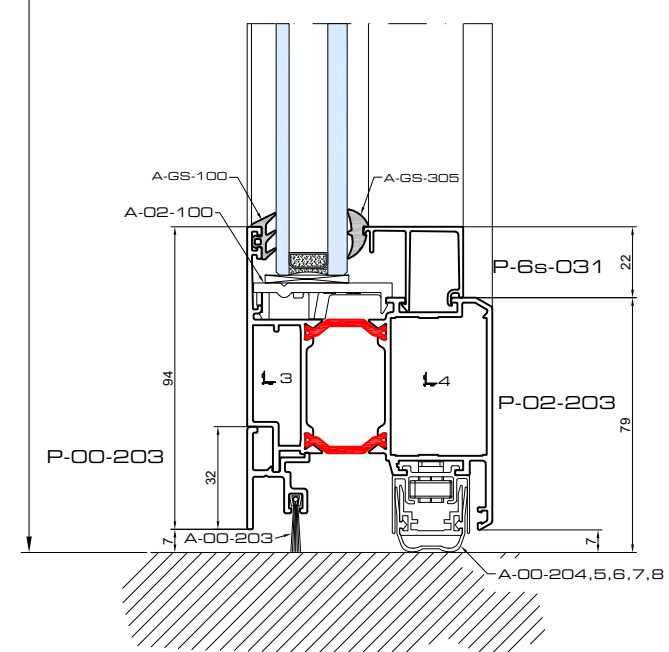
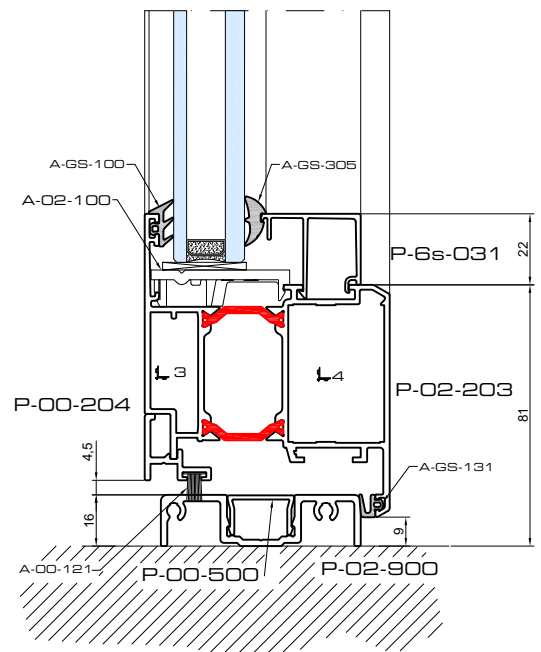

hcdeur_enkel_binnen

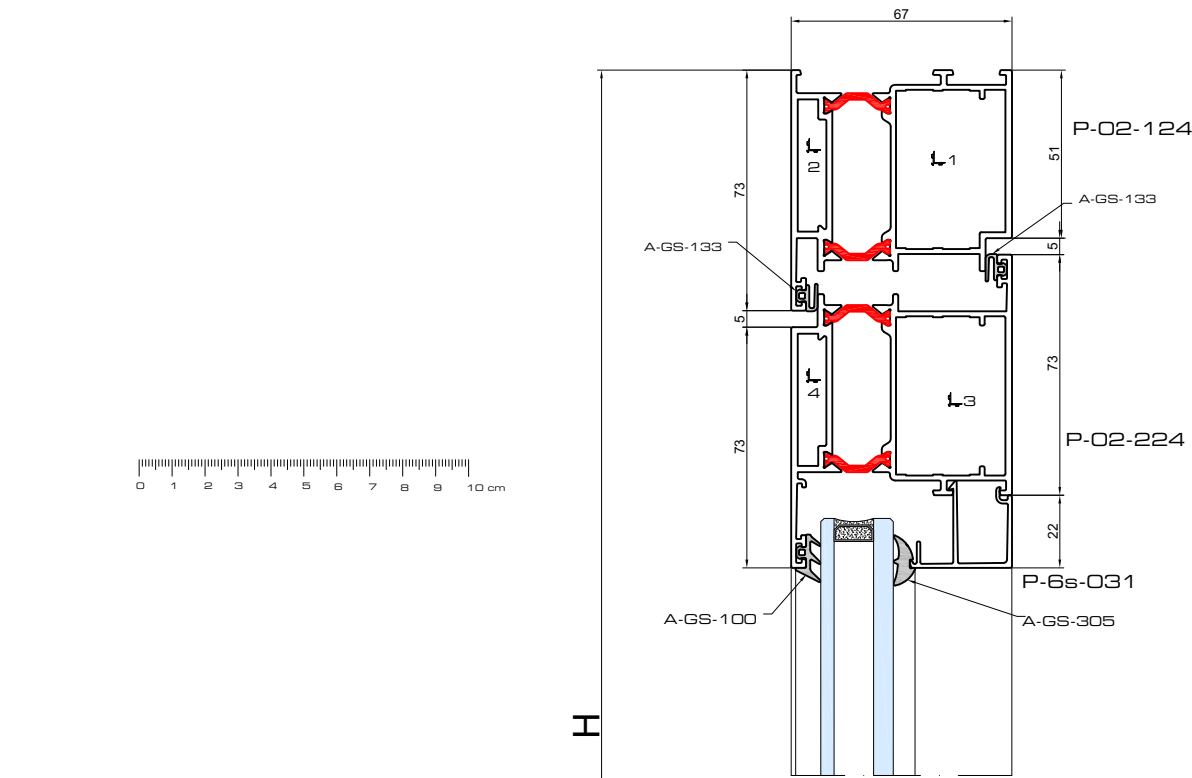

	B	#	H	#
P-02-124	B	1	-	-
P-02-124	-	-	H	1
P-02-224	B - 112	2	H - 63	2
			H - 66	2
P-02-901	B - 126	1	-	-
P-00-500	B - 126	1	-	-
P-00-206	B - 141	1	-	-
P-00-205	B - 144	1	-	-
P-6s-031	B - 258	2	H - 253	2
			H - 255	2
P-00-304,5,6,7,8	B - 146	1	-	-

	#
A-02-100	4
A-02-210	1
A-00-105	4
A-00-210	1
A-00-211	1
A-02-218	1

	#
1 A-PH-4725	2
2 A-PH-4006	2
3 A-PH-4725	4
4 A-PH-4006	4

	#
A-BS-254	1
A-BS-255	1
A-BS-247	1
A-BS-250	1
A-BS-251	2
A-BF-080	3
A-BF-087	3

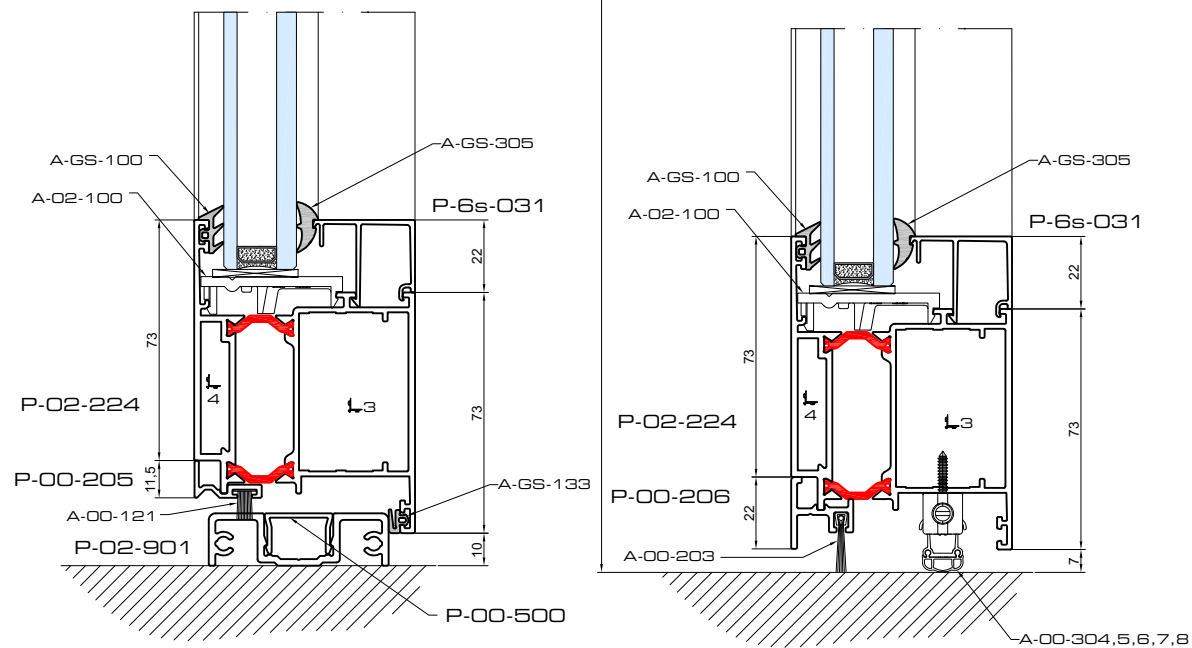
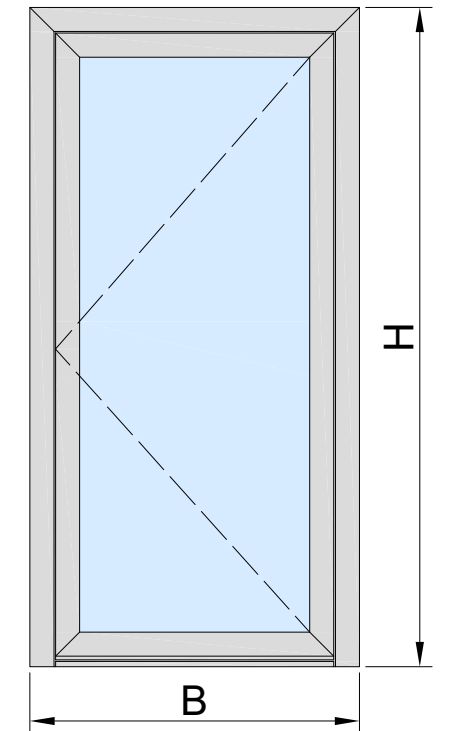

	B	H
A-GS-100	2B + 2H	
A-GS-133	3B + 4H	
A-GS-305	2B + 2H	
A-00-203	B - 150	H - 223
A-00-121	B - 150	H - 226

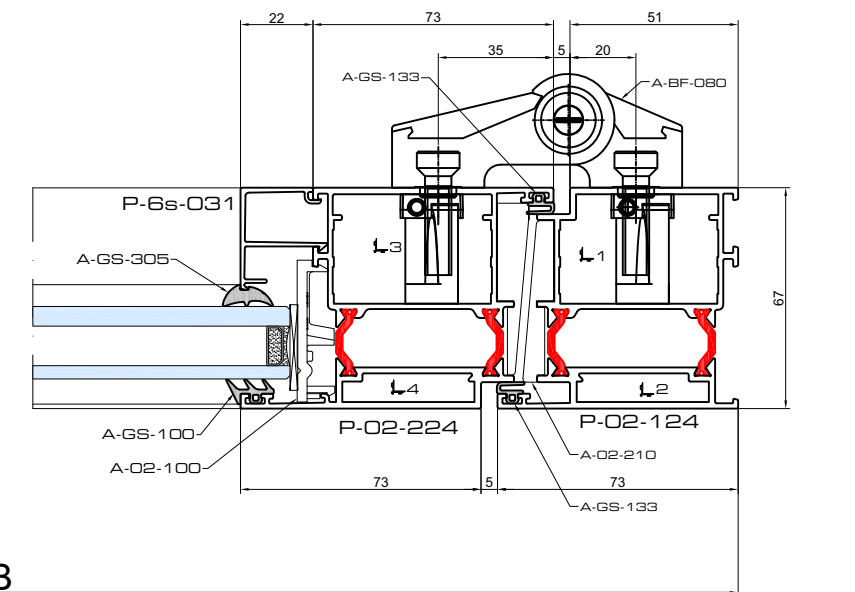
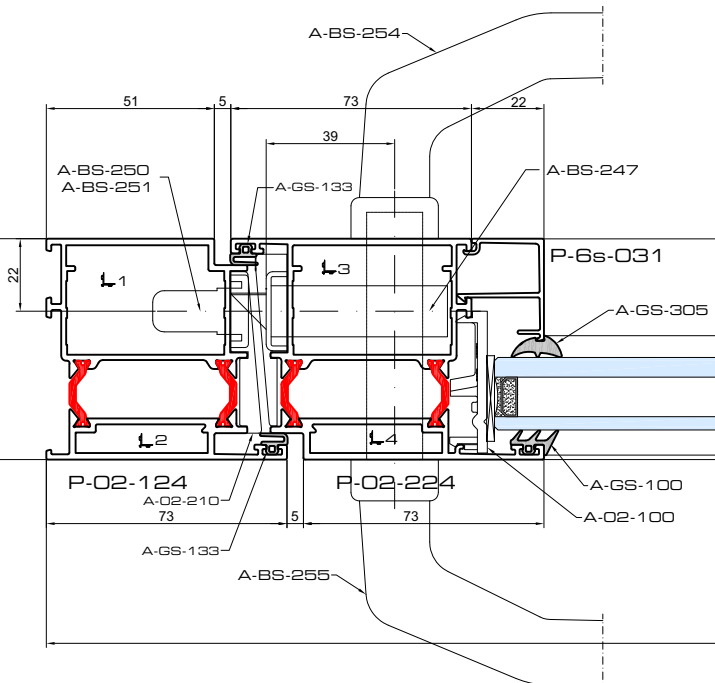
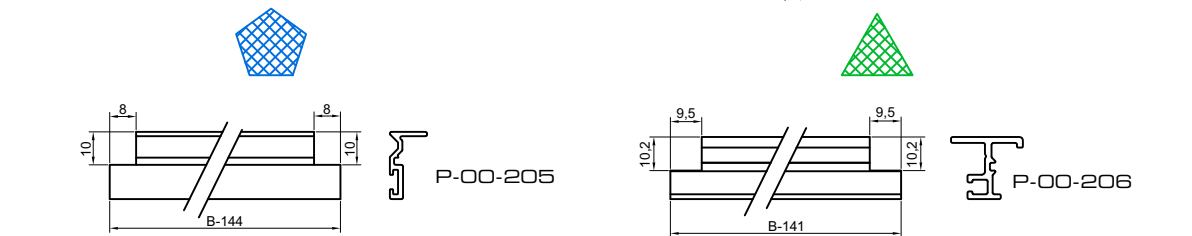

hcdeur_enkel_binnen_vlak

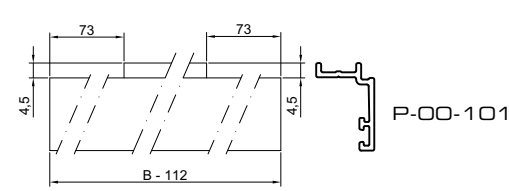
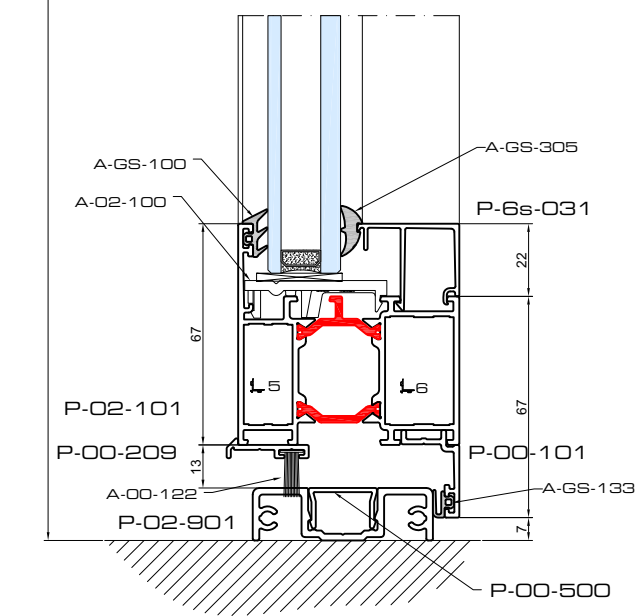
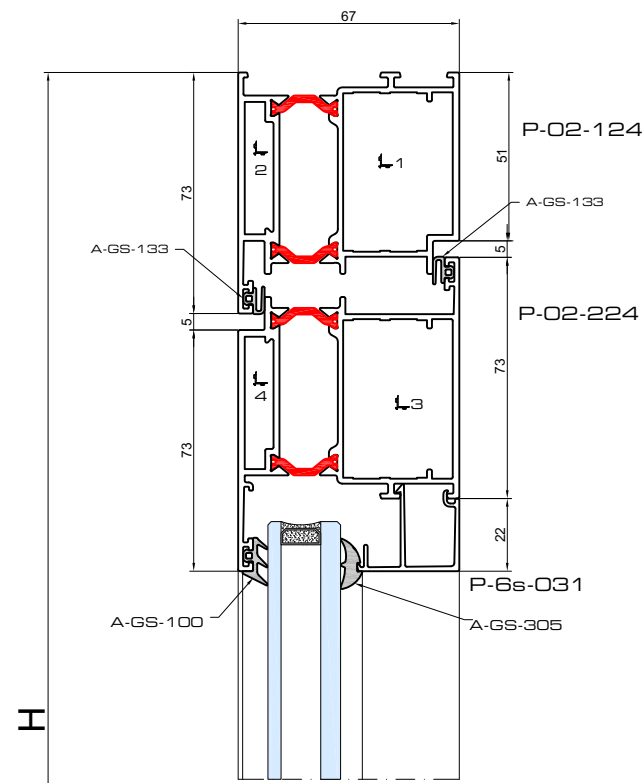

		B	#	H	#
P-02-124		B	1	-	-
P-02-224		-	-	H	1
		B - 112	2	-	-
		-	-	H - 63	2
P-02-101		B - 258	1	-	-
P-02-901		B - 126	1	-	-
P-00-500		B - 126	1	-	-
P-00-206		B - 112	1	-	-
P-00-205		B - 156	1	-	-
P-6s-031		B - 258	2	H - 253	2



	#
A-02-100	4
A-02-210	1
A-00-105	4
A-02-218	1

	#		#
1	A-PH-4725	2	
2	A-PH-4006	2	
3	A-PH-4725	2	
4	A-PH-4006	2	
5		A-TV-068	2
6		A-TV-002	2

	#
A-BS-254	1
A-BS-255	1
A-BS-247	1
A-BS-250	1
A-BS-251	2
A-BF-080	3
A-BF-087	3

A-GS-100	2B + 2H
A-GS-133	3B + 4H
A-GS-305	2B + 2H
A-00-122	B - 150

	B	H
	B - 272	H - 217

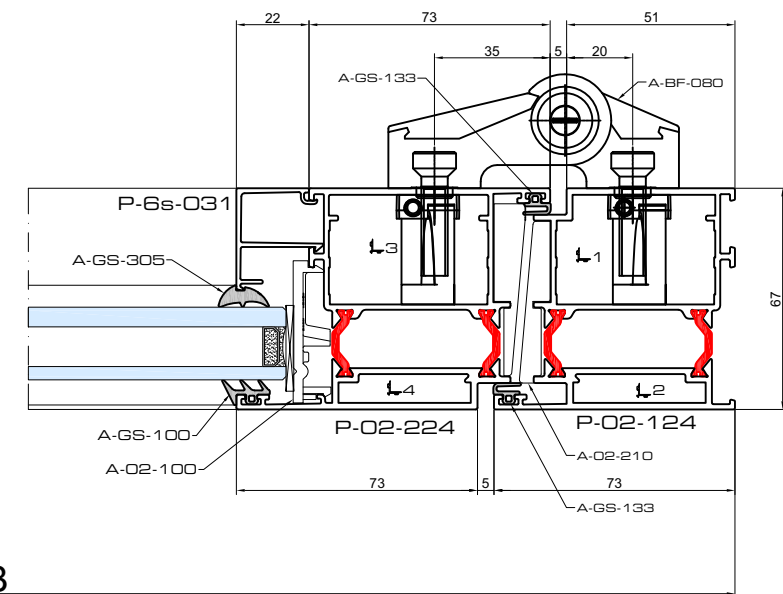
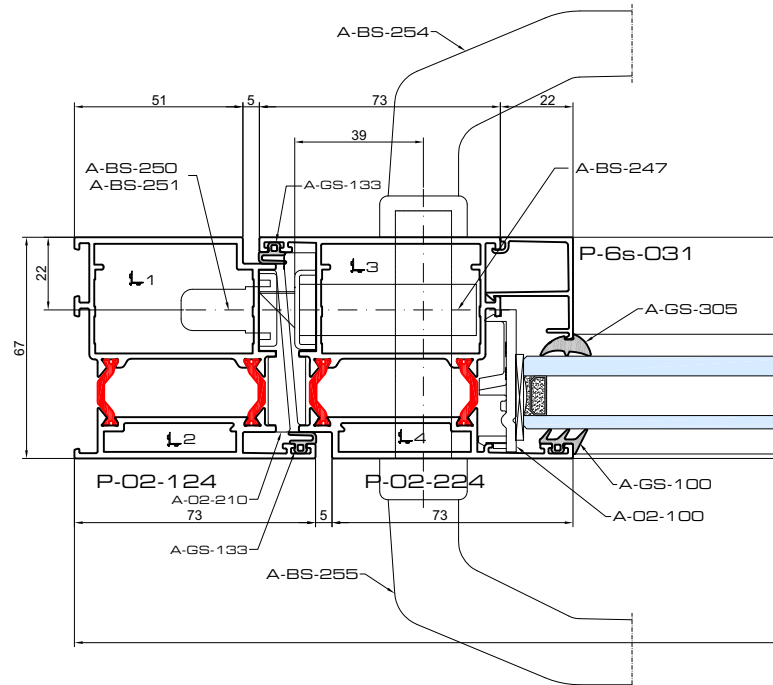
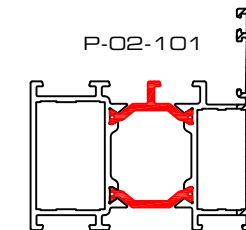
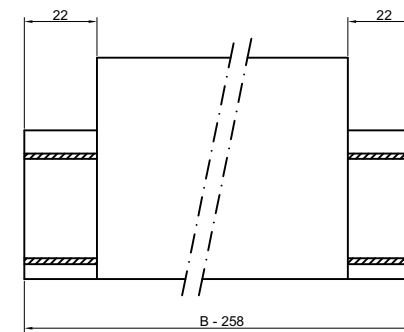
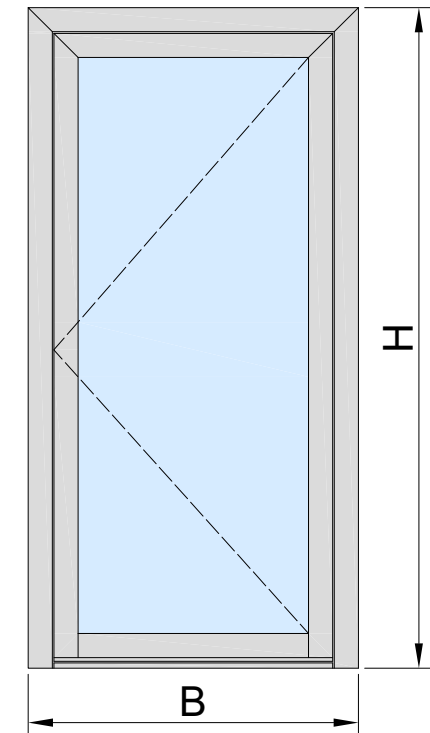

hcdeur_enkel_binnen_vlak_kader

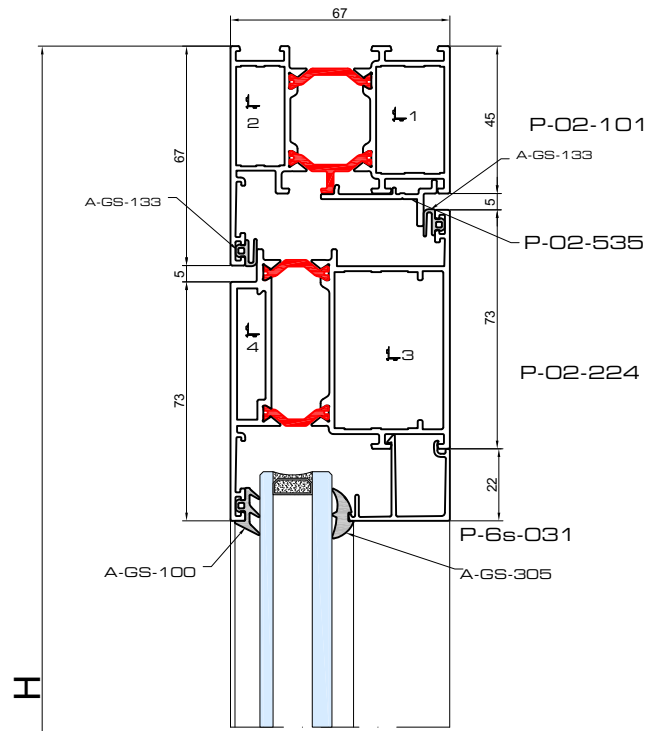

		B	#	H	#
P-02-101		B	1	-	-
P-02-101		-	-	H	1
P-02-224		B - 100	2	▲ H - 57	2
				● H - 60	2
P-02-535		B - 81.5	1	-	-
P-02-535		-	-	H - 40.8	2
● P-02-901		B - 114.4	1	-	-
● P-00-500		B - 114.4	1	-	-
● P-00-205		B - 132	1	-	-
▲ P-00-206		B - 129	1	-	-
P-6s-031		B - 246	2	▲ H - 247	2
				● H - 250	2
▲ P-00-204,5,6,7,8		B - 134	1	-	-

	#
A-02-100	4
A-02-212	1
A-00-105	4
● A-00-210	1
▲ A-00-211	1
● A-02-219	1

	P	S	#
1	A-PH-3221	A-SH-3221	2
2	A-PH-3015	A-SH-3015	2
3	A-PH-4725		4
4	A-PH-4006		4

	#
A-BS-254	1
A-BS-255	1
A-BS-247	1
A-BS-256	2
A-BS-257	1
A-BF-080	3
A-BF-087	3

	B	H
A-GS-133	3B + 4H	
A-GS-100	2B + 2H	
A-GS-305	2B + 2H	
▲ A-00-203	B - 140	▲ H - 217
● A-00-121	B - 140	● H - 220

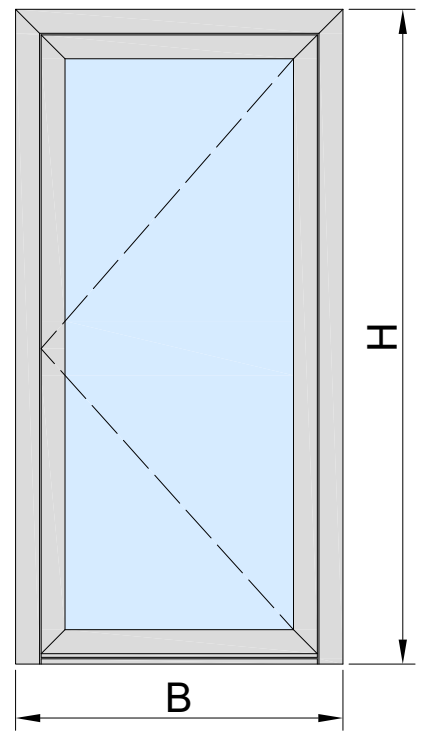
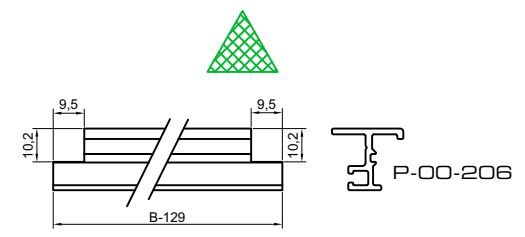
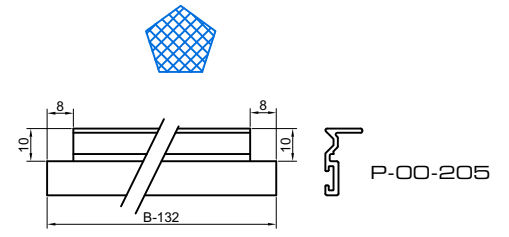
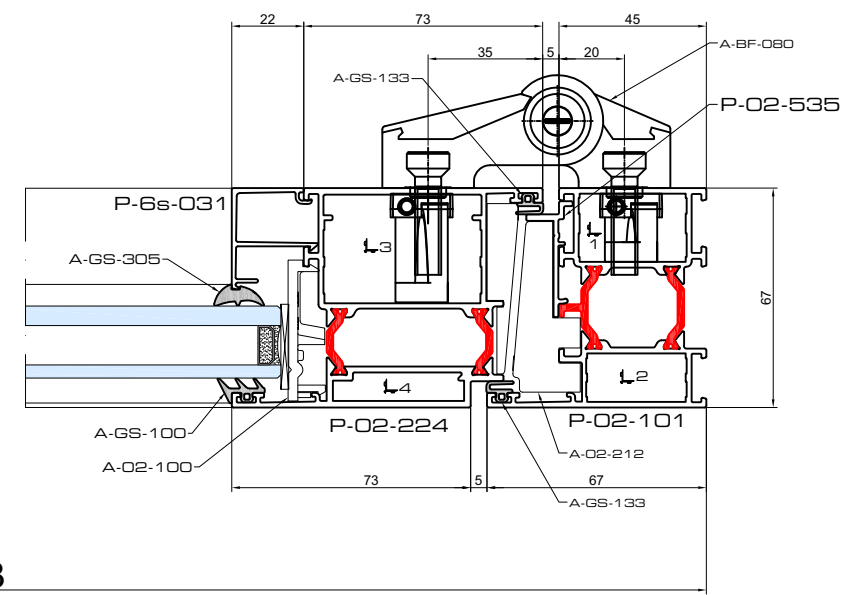
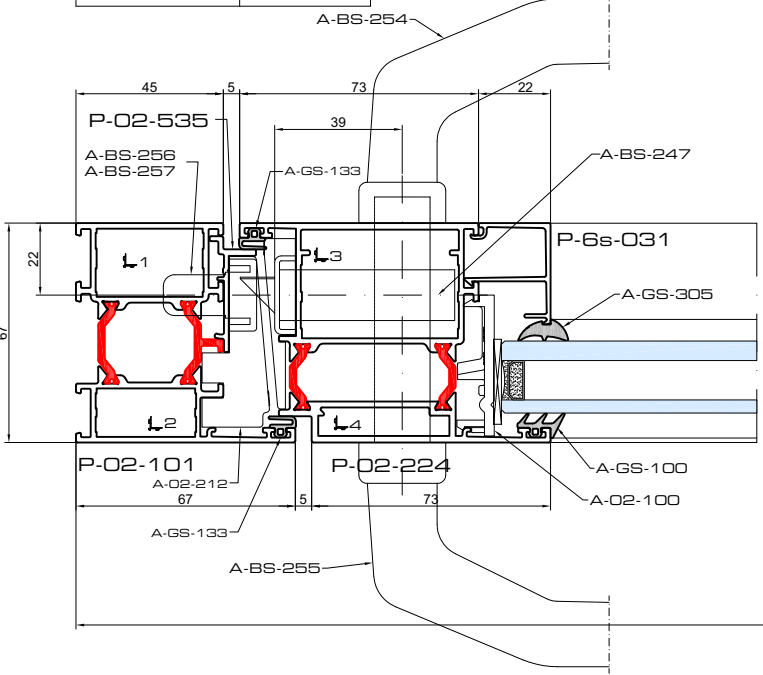
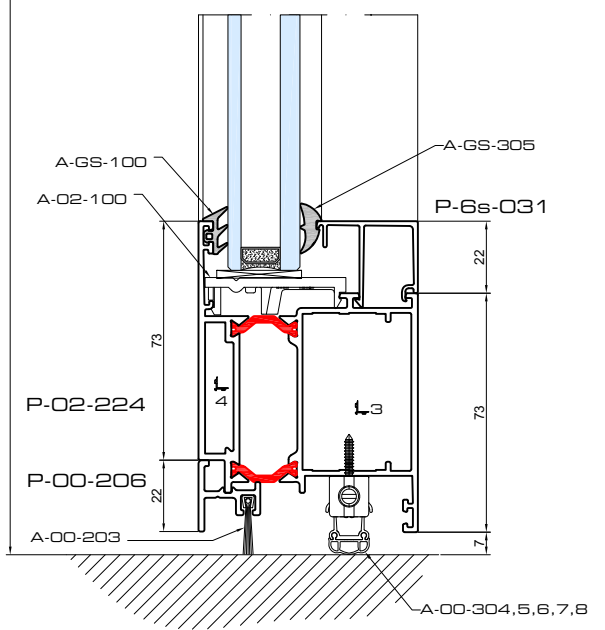
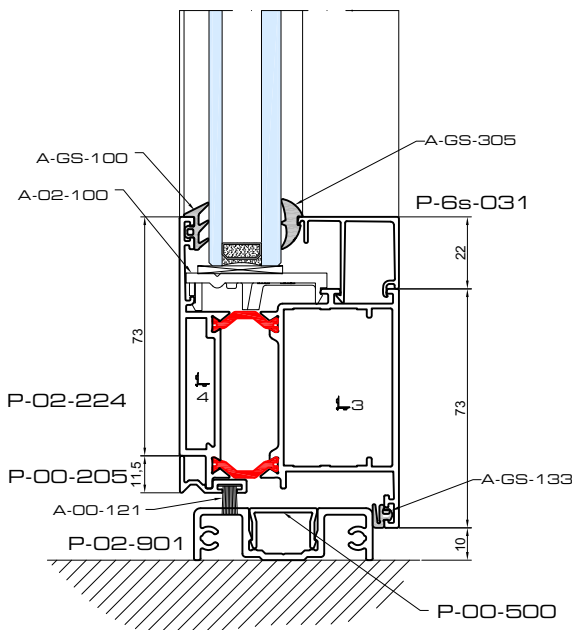

hcdeur_enkel_binnen_vlak_vleugel

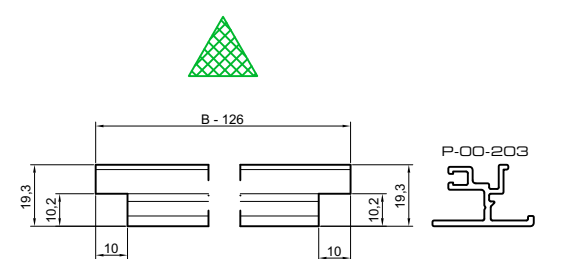
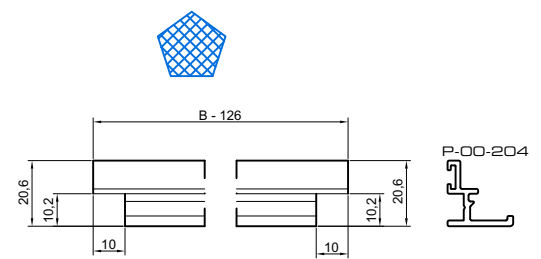
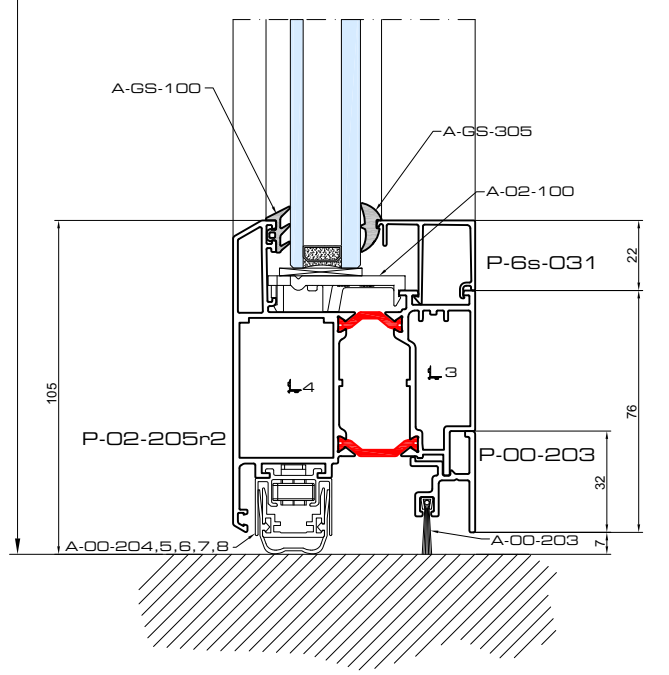
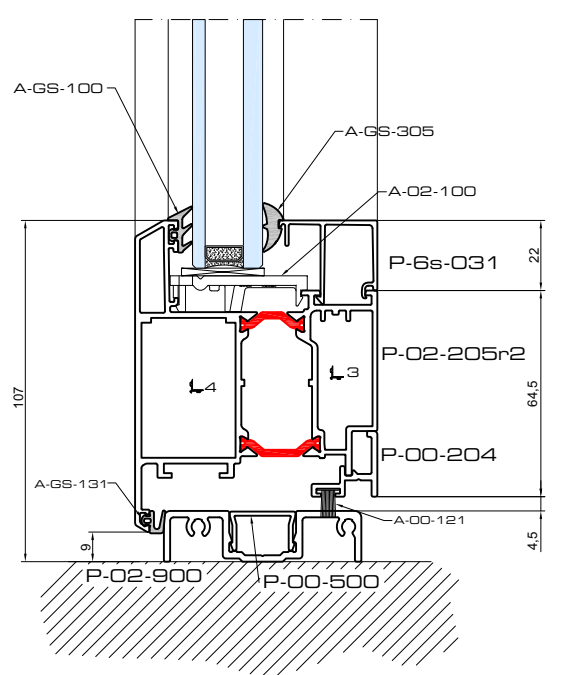
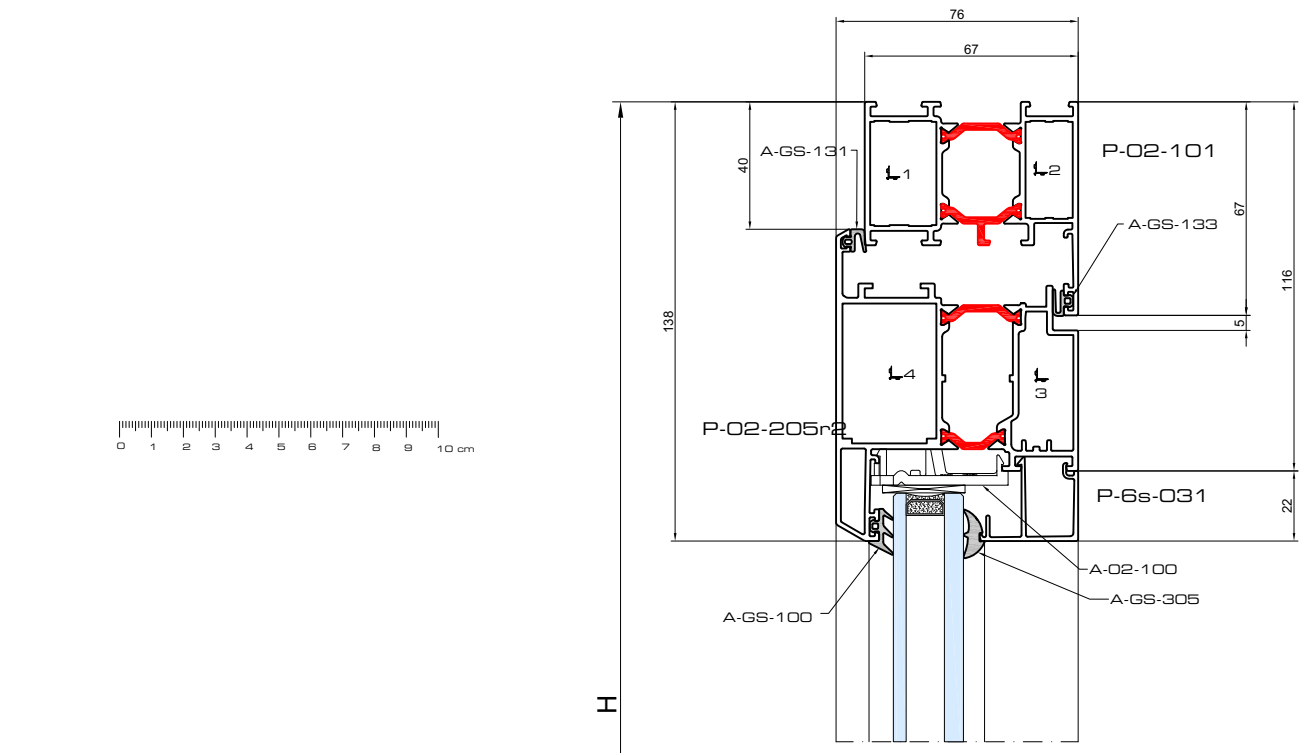

		B	#	H	#
P-02-101		B	1	-	-
P-02-101		-	-	H	1
P-02-205r2		B - 80	2	▲ H - 47	2
				● H - 49	2
▲ P-02-900		B - 94	1	-	-
▲ P-00-500		B - 94	1	-	-
▲ P-00-203		B - 126	1	-	-
● P-00-204		B - 126	1	-	-
P-6s-031		B - 231.6	2	▲ H - 242.6	2
				● H - 244.6	2
▲ A-00-204,5,6,7,8		B - 123	1	-	-

	#
A-00-105	6
A-00-100	6
A-02-100	4
▲ A-02-204	1
● A-02-900	1

	LP	LS	#
1	A-PH-3221	A-SH-3221	2
2	A-PH-3015	A-SH-3015	2
3	A-PH-4206		4
4	A-PH-4229	A-SH-4229	4

	#
A-BS-254	1
A-BS-255	1
A-BS-242	1
A-BS-250	1
A-BS-251	2
A-BF-063	3

	B	H
	B - 245.6	▲ H - 212.6
		● H - 214.6

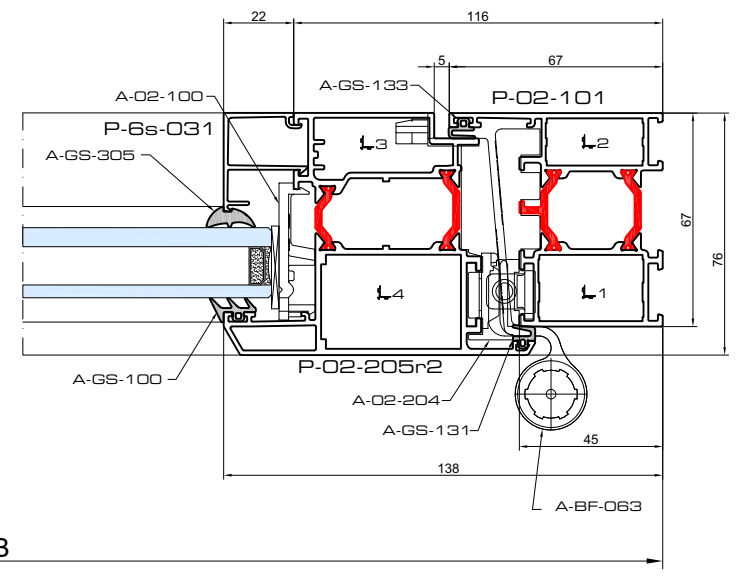
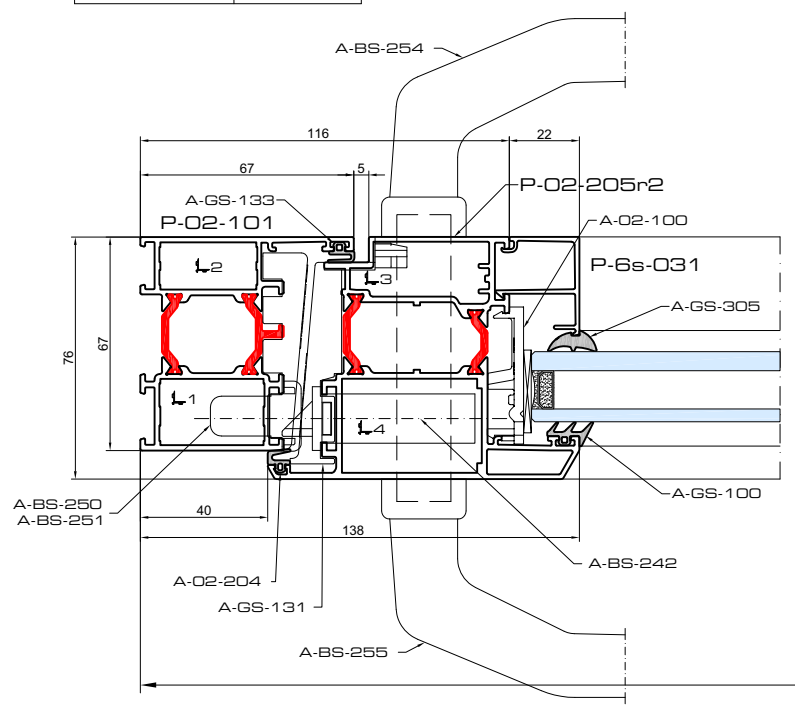
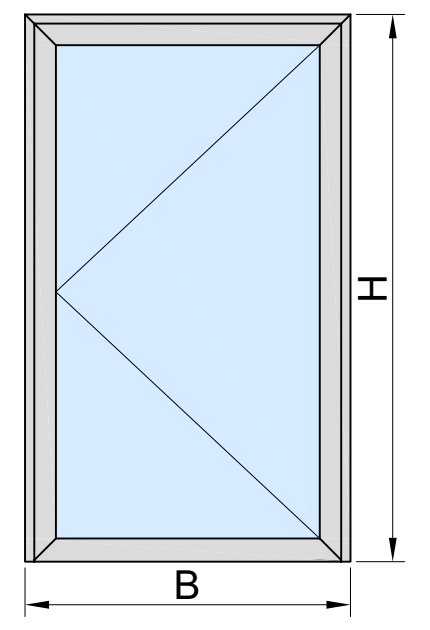

hcdeur_enkel_buiten

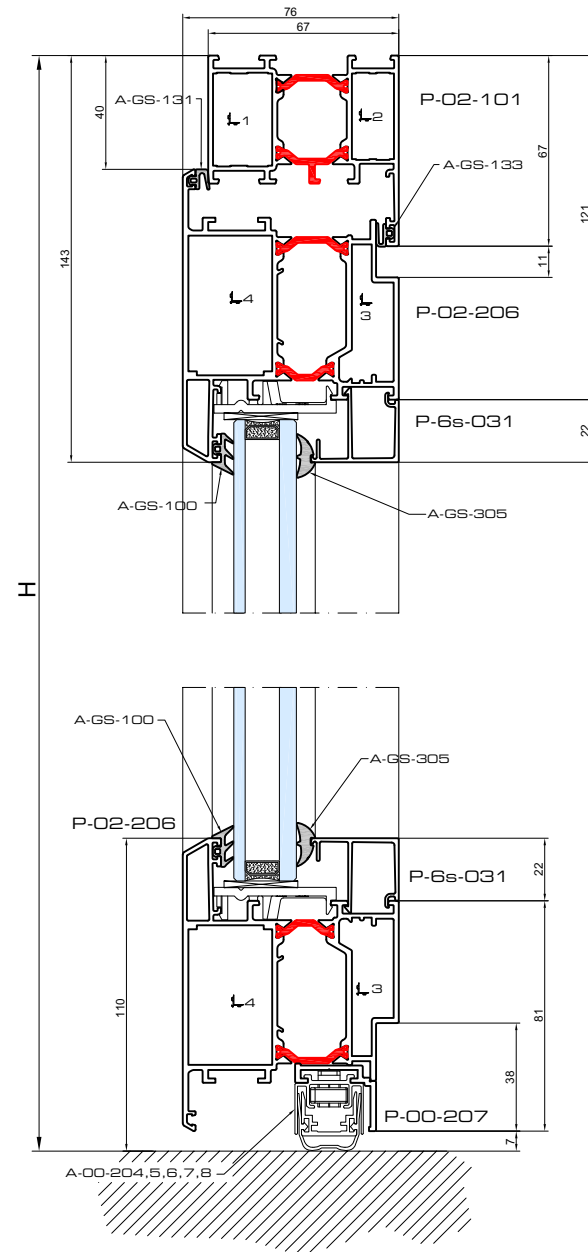

		B	#	H	#
P-02-101		B	1	-	-
P-02-101		-	-	H	1
P-02-206		B - 80	2	H - 47	2
P-6s-031		B - 242	2	H - 209	2
A-00-204,5,6,7,8		B - 123	1		

	#
A-00-105	6
A-02-100	4
A-02-203	1
A-02-205	1

			#
1	A-PH-3015	A-SH-3015	2
2	A-PH-3221	A-SH-3221	2
3	A-PH-4707		4
4	A-PH-4730	A-SH-4730	4

	#
A-BS-254	1
A-BS-255	1
A-BS-237	1
A-BS-250	1
A-BS-251	2
A-BF-063	3



A-GS-131	2B + 2H
A-GS-133	B + 2H
A-GS-100	2B + 2H
A-GS-305	2B + 2H

	B	H
	B - 256	H - 223
	B - 256	H - 223

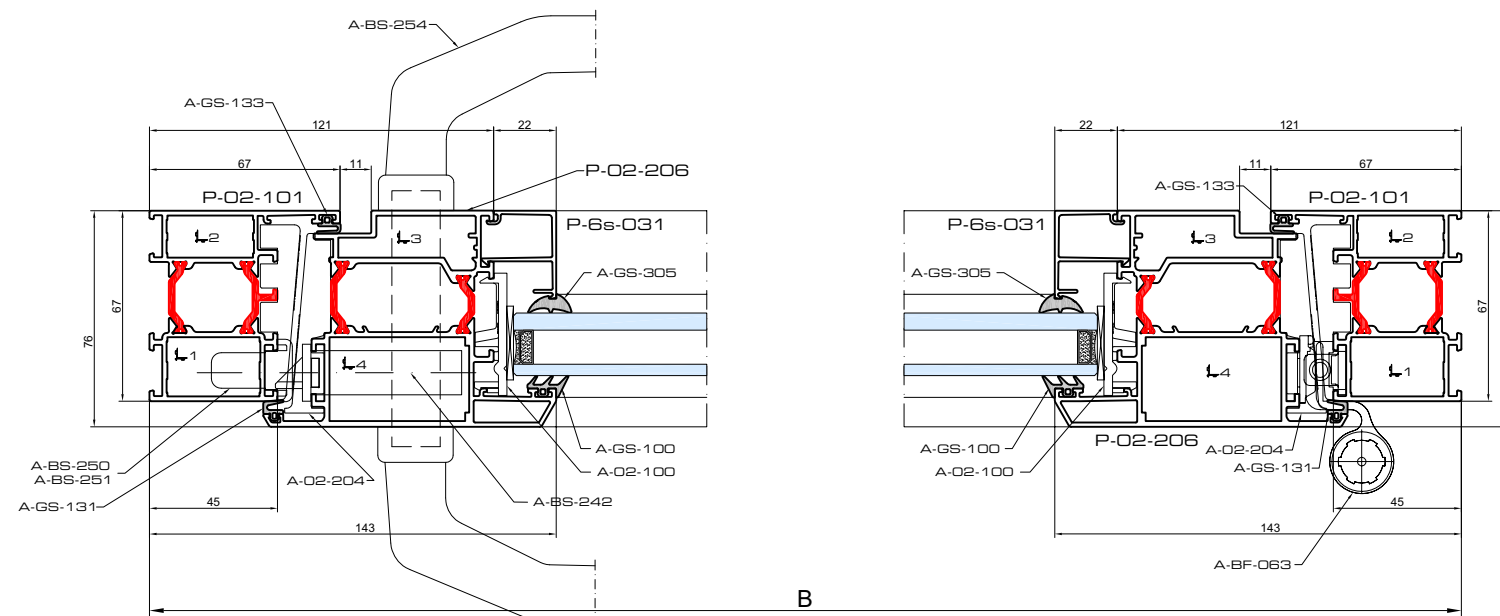
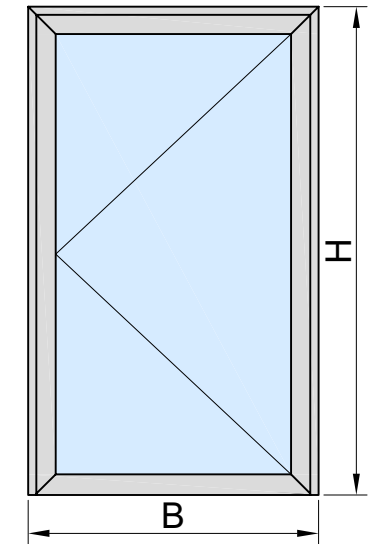

hcdeur_enkel_buiten_206

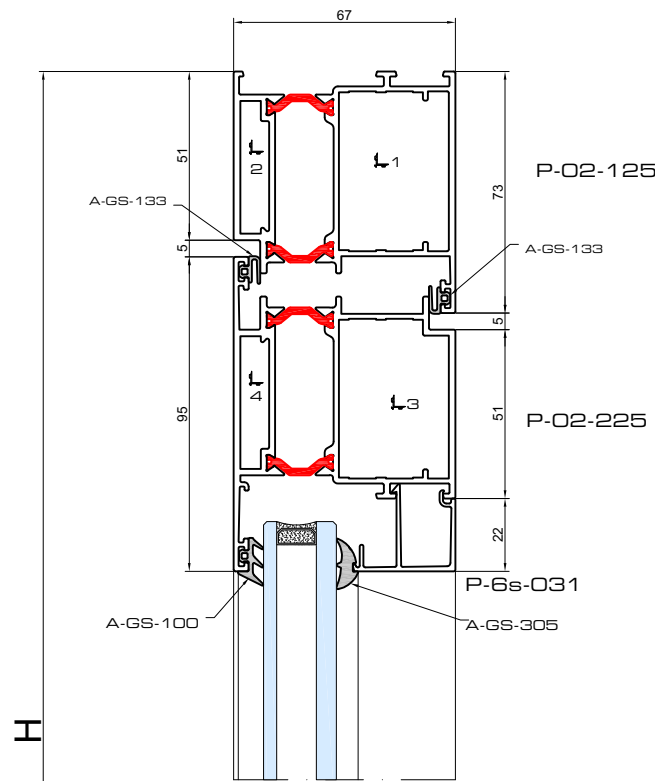

		B	#	H	#
P-02-125		B	1	-	-
P-02-225		B - 112	2	▲ H - 63	2
P-02-901		B - 126	1	● H - 66	2
P-00-500		B - 126	1	-	-
P-00-205		B - 144	1	-	-
P-00-206		B - 141	1	-	-
P-6s-031		B - 258	2	▲ H - 253	2
A-00-304,5,6,7,8		B - 146	1	● H - 256	2

	#
A-00-105	4
A-02-100	4
A-02-214	1
A-02-242	1
A-02-218	1
A-00-210	1
A-00-211	1

	#
1 A-PH-4725	2
2 A-PH-4006	2
3 A-PH-4725	4
4 A-PH-4006	4

	#
A-BS-254	1
A-BS-255	1
A-BS-247	1
A-BS-250	1
A-BS-251	2
A-BF-080	3
A-BF-087	3

A-GS-133	3B + 4H
A-GS-100	2B + 2H
A-GS-305	2B + 2H
A-00-203	B - 150
A-00-121	B - 150

	B	H
	B - 272	▲ H - 223
		● H - 226

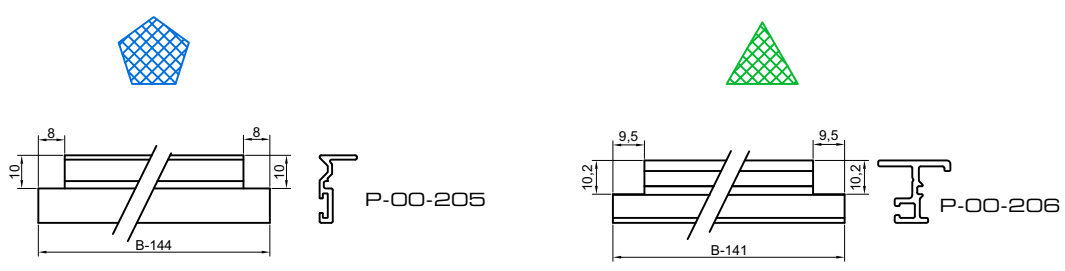
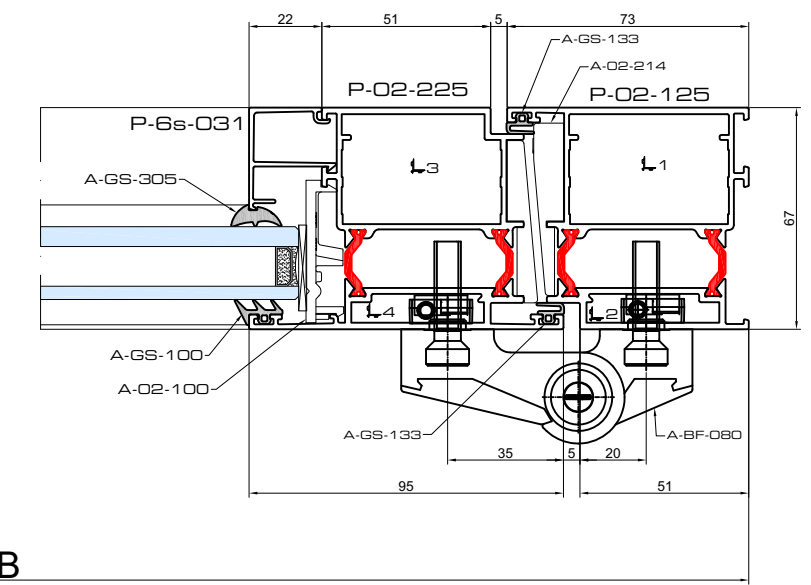
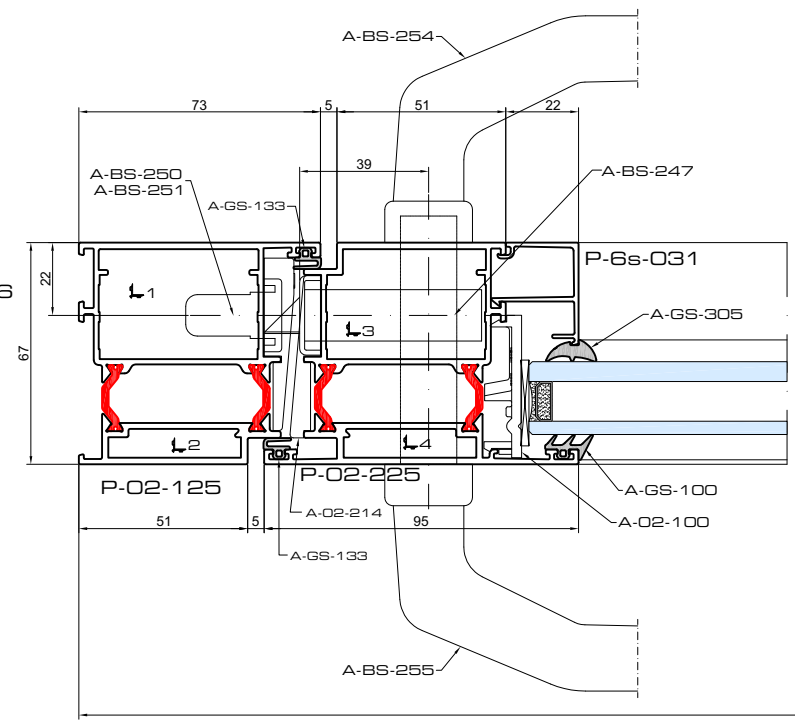
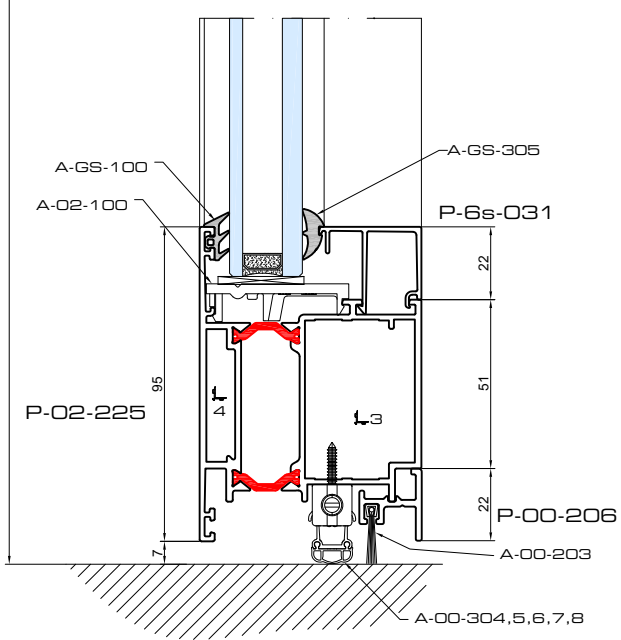
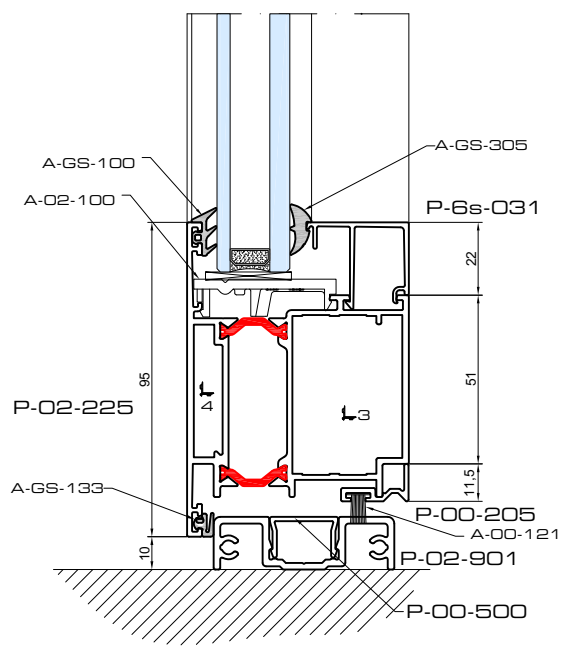
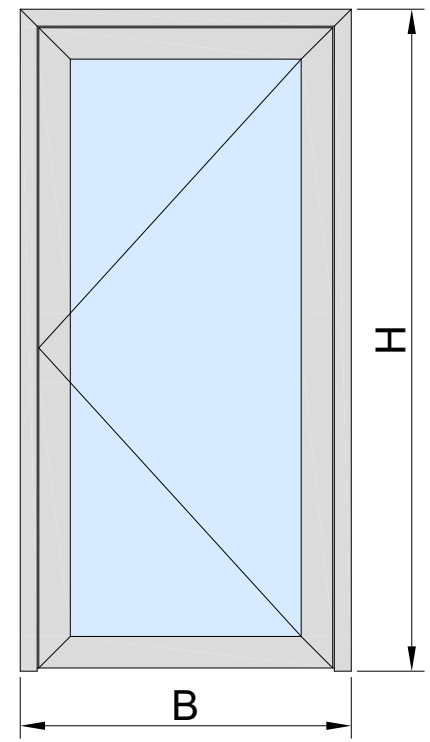

hcdeur_enkel_buiten_vlak

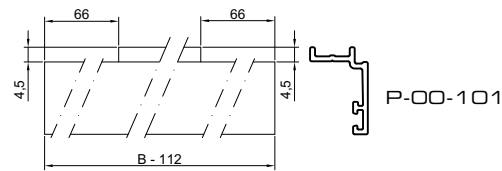
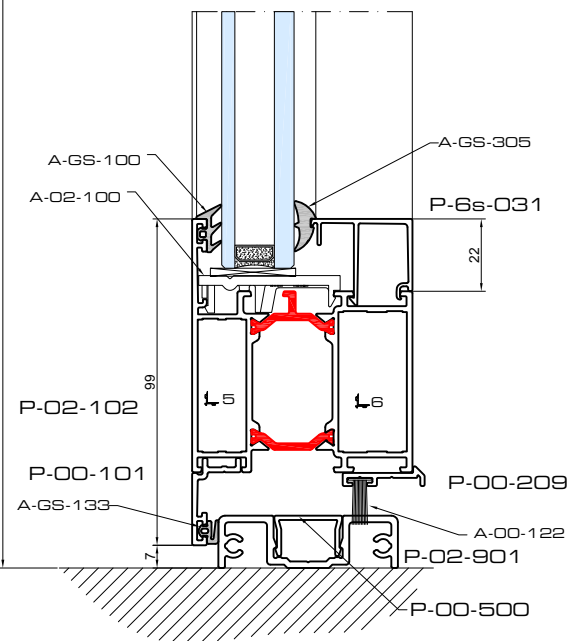
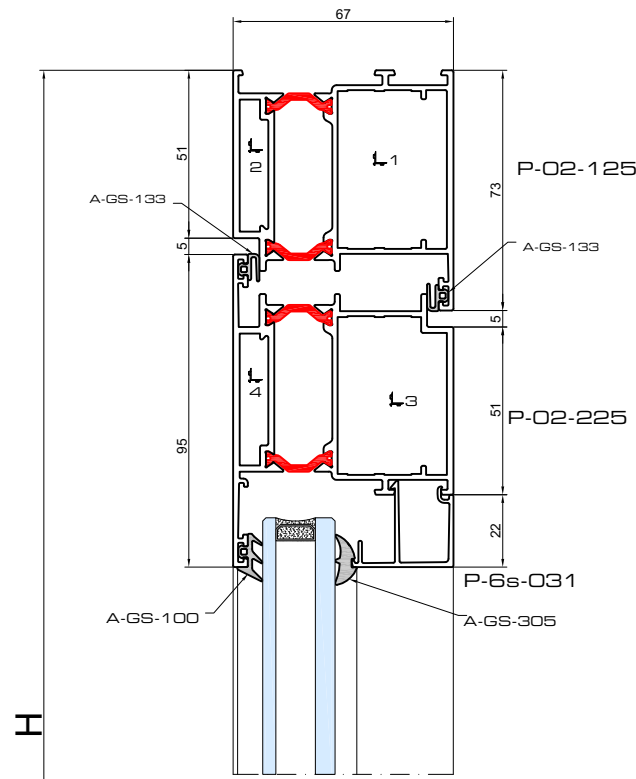

		B	#	H	#
P-02-125		B	1	-	-
		-	-	H	1
P-02-225		B - 112	2	-	-
		-	-	H - 85	1
P-02-101		B - 258	1	-	-
P-02-901		B - 126	1	-	-
P-00-500		B - 126	1	-	-
P-00-101		B - 112	1	-	-
P-00-209		B - 156	1	-	-
P-6s-031		B - 258	2	H - 257	2

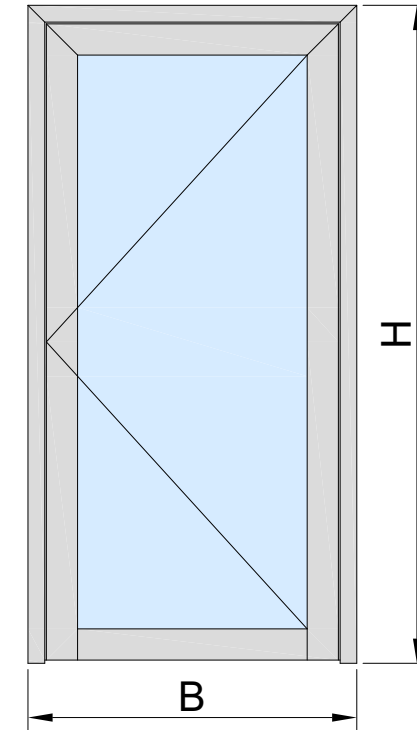

	#
A-00-105	4
A-02-100	4
A-02-214	1
A-02-218	1
A-02-242	1

	P	S	#
1	A-PH-4725		2
2	A-PH-4006		2
3	A-PH-4725		2
4	A-PH-4006		2
5		A-TV-069	2
6		A-TV-003	2

	#
A-BS-254	1
A-BS-255	1
A-BS-247	1
A-BS-250	1
A-BS-251	2
A-BF-080	3
A-BF-087	3

A-GS-133	3B + 4H
A-GS-100	2B + 2H
A-GS-305	2B + 2H
A-00-203	B - 150
A-00-122	B - 150

	B	H
	B - 272	H - 227

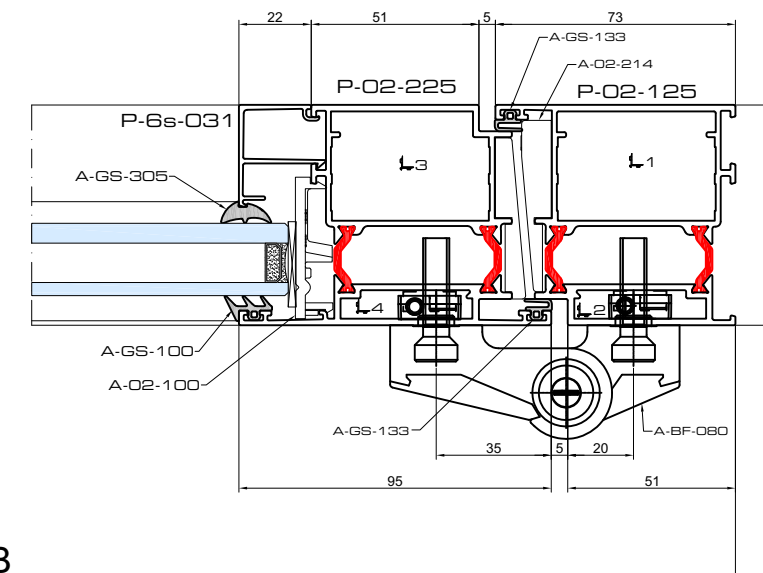
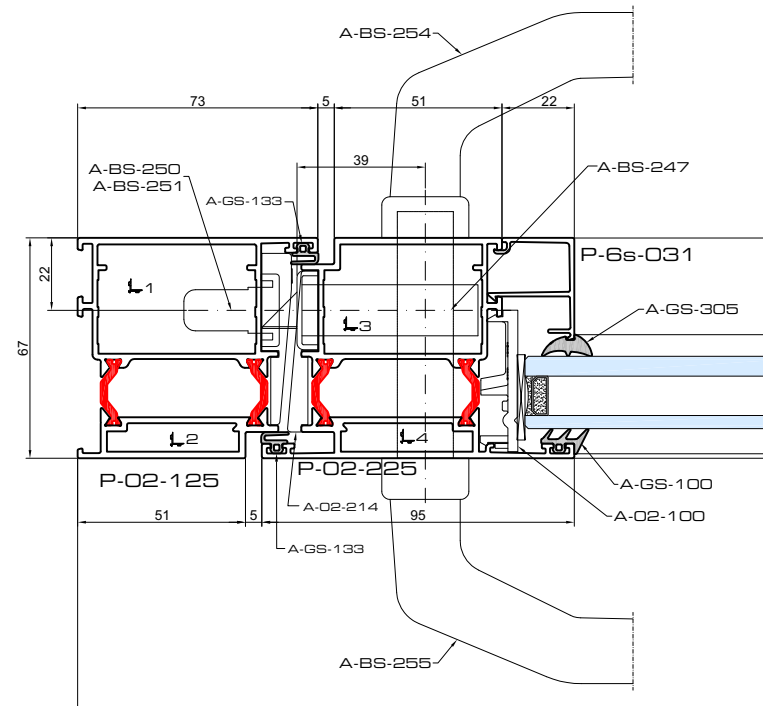
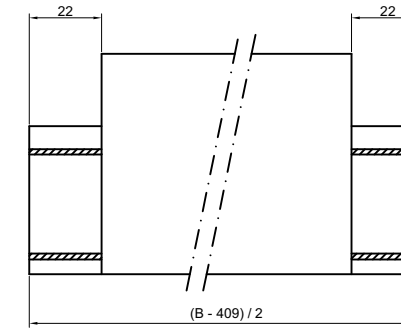

hcdeur_enkel_buiten_vlak_kader

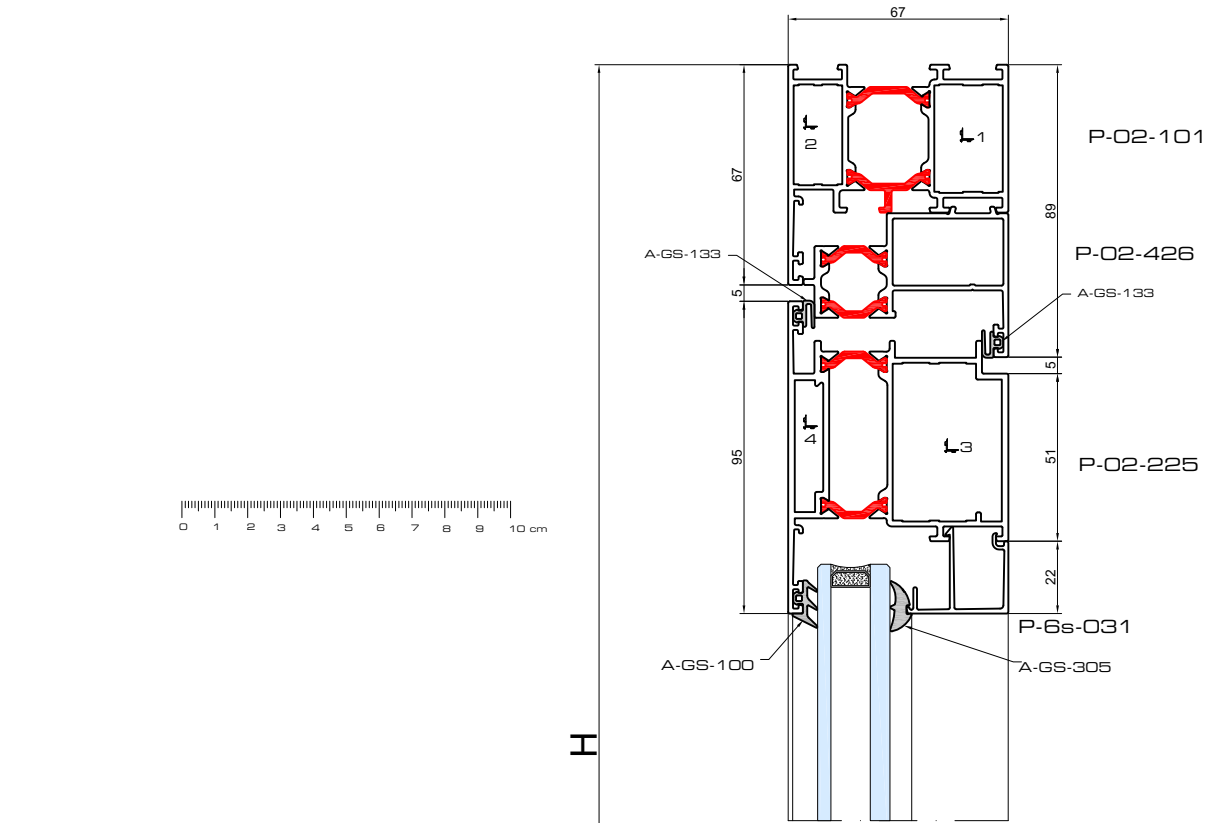

		B	#	H	#
P-02-101		B	1	-	-
P-02-101		-	-	H	1
P-02-225		B - 144	2	▲ H - 79	2
P-02-426		B - 90	1	● H - 82	2
P-02-426		-	-	H - 45	2
P-02-901		B - 158	1	-	-
P-00-500		B - 158	1	-	-
P-00-205		B - 176	1	-	-
P-00-206		B - 173	1	-	-
P-6s-031		B - 290	2	▲ H - 269	2
P-6s-031		B - 290	2	● H - 272	2
A-00-304,5,6,7,8		B - 179	1	-	-

	#
A-BS-254	1
A-BS-255	1
A-BS-247	1
A-BS-256	1
A-BS-257	2
A-BF-081	3
A-BF-087	3

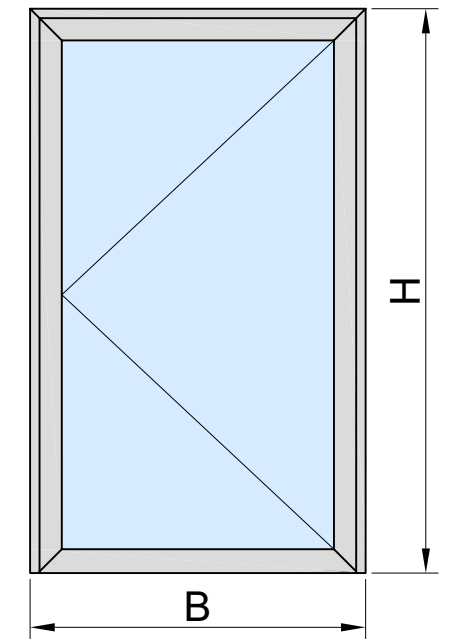

	#
A-00-105	4
A-02-100	4
A-02-216	1
A-02-220	1
A-00-210	1
A-00-211	1

	#
1 A-PH-3221 A-SH-3221	2
2 A-PH-3015 A-SH-3015	2
3 A-PH-4725	4
4 A-PH-4006	4

A-GS-133	3B + 4H
A-GS-100	2B + 2H
A-GS-305	2B + 2H
A-00-203	B - 180
A-00-121	B - 180

B	H
B - 304	▲ H - 239
	● H - 242

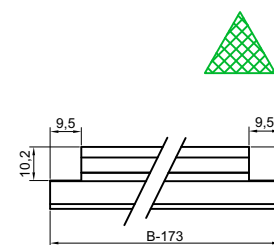
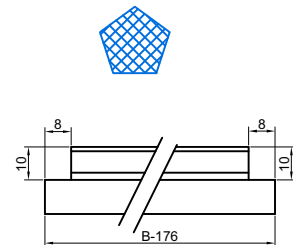
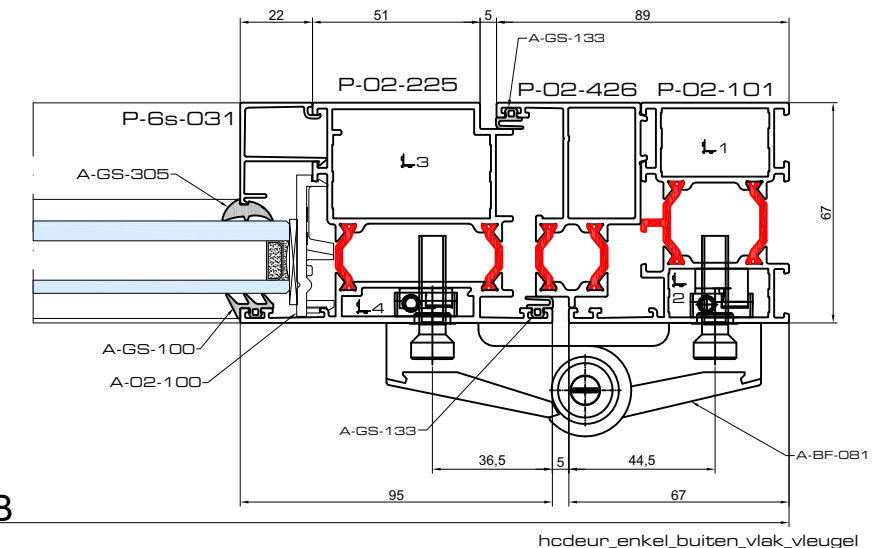
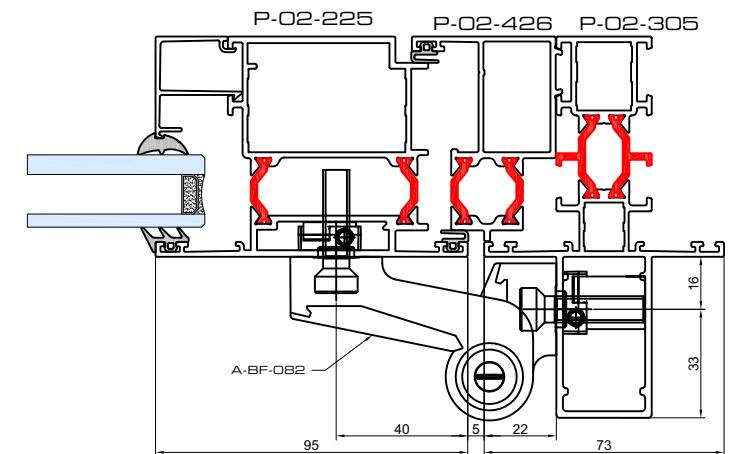
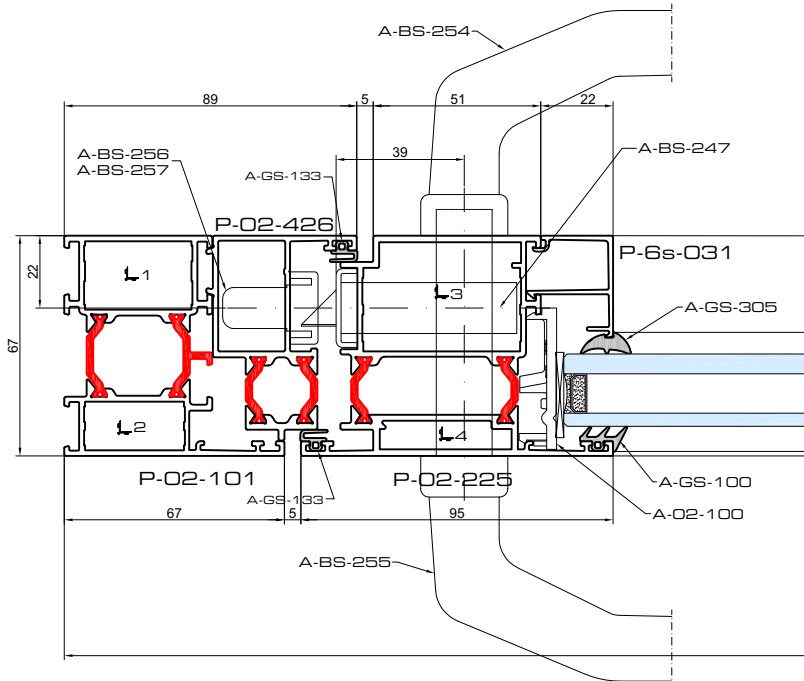
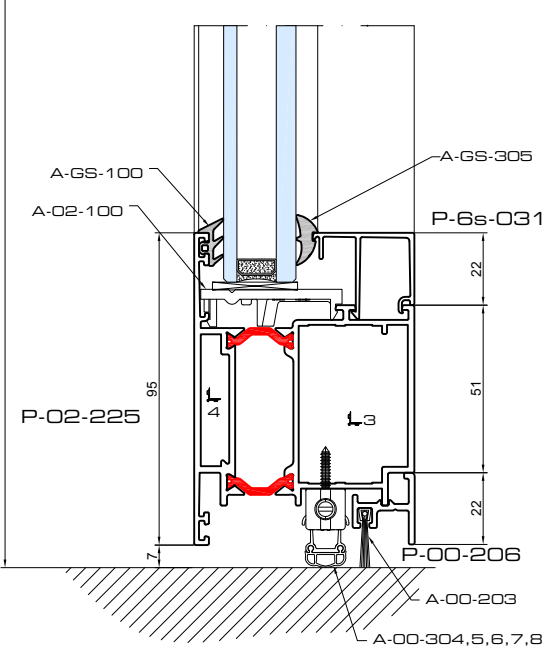
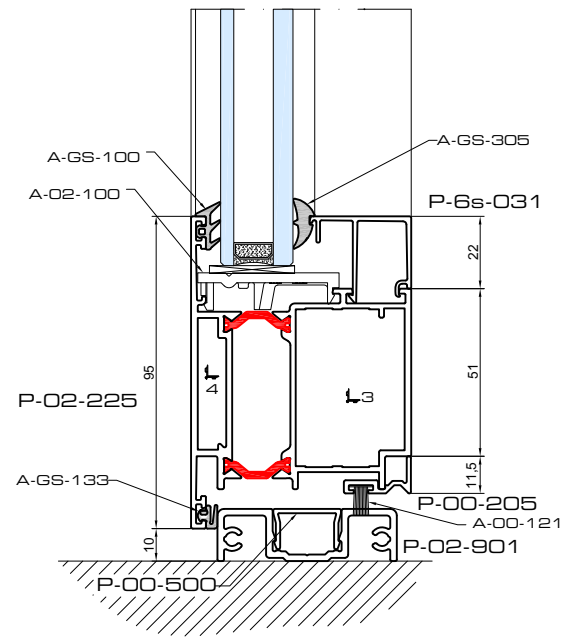

hdeur_enkel_buiten_vlak_vleugel

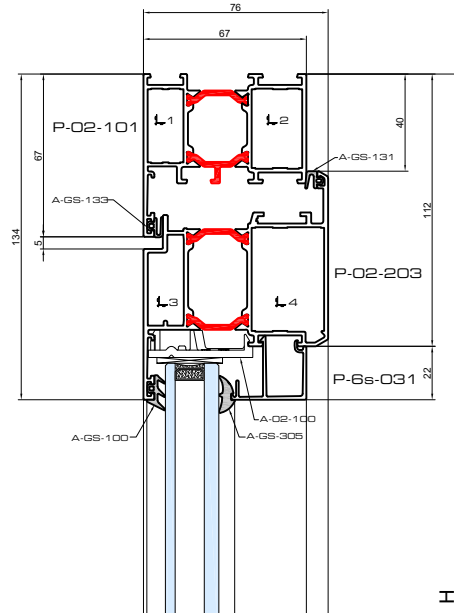

		B	#	H	#
P-02-101		B	1	-	-
P-02-101		-	-	H	1
P-02-203		(B - 85) / 2	4	▲ H - 47	4
				● H - 49	4
P-02-400		-	-	▲ H - 81	1
				● H - 83	1
● P-02-900		B - 94	1	-	-
● P-00-500		B - 94	1	-	-
▲ P-00-203		(B - 181) / 2	2	-	-
● P-00-204		(B - 181) / 2	2	-	-
P-6s-031		(B - 373) / 2	4	▲ H - 235	4
				● H - 237	4
▲ A-00-204,5,6,7,8		(B - 171) / 2	2	-	-

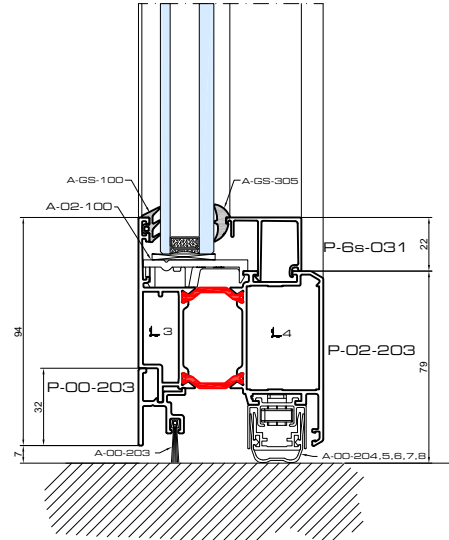
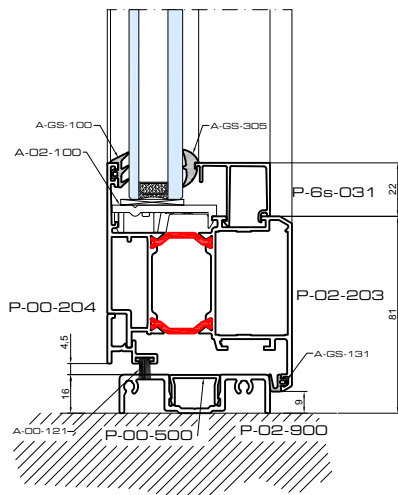
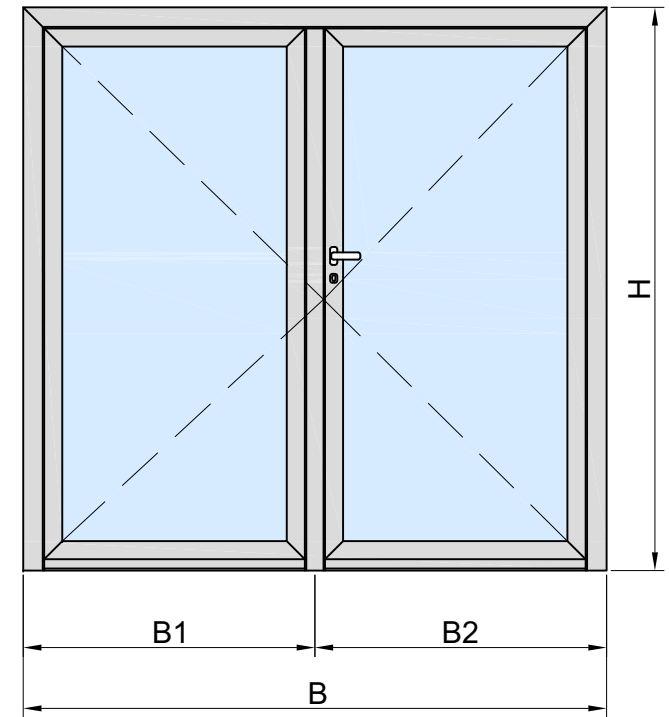

	#
A-00-105	10
A-02-100	8
A-02-203	1
▲ A-02-205	1
● A-02-900	1

	P	S	#
1	A-PH-3015	A-SH-3015	2
2	A-PH-3221	A-SH-3221	2
3	A-PH-3706		8
4	A-PH-4230	A-SH-4230	8

	#
A-BS-254	1
A-BS-255	1
A-BS-242	1
A-BS-250	1
A-BS-251	2
A-BF-063	1
A-BF-063	6

A-GS-131	B + 3H
A-GS-133	B + 4H
A-GS-100	2B + 4H
A-GS-305	2B + 4H
▲ A-00-203	(B - 177) / 2
● A-00-121	(B - 177) / 2

	B	H
	(B - 401) / 2	▲ H - 205
		● H - 207
	(B - 401) / 2	▲ H - 205
		● H - 207

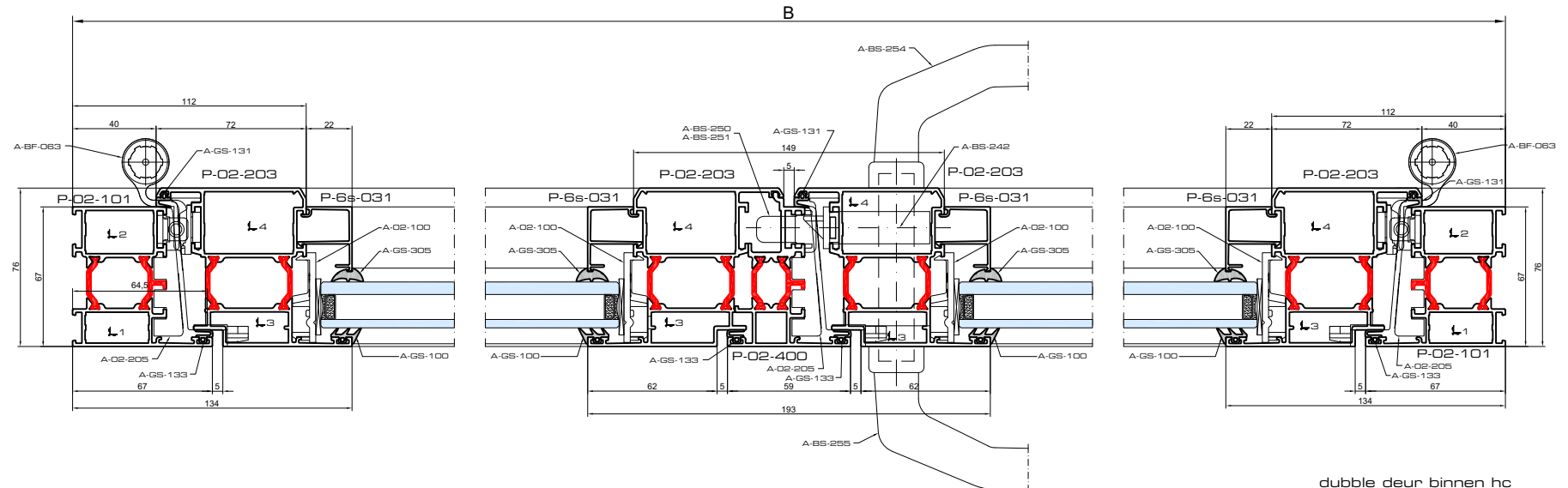
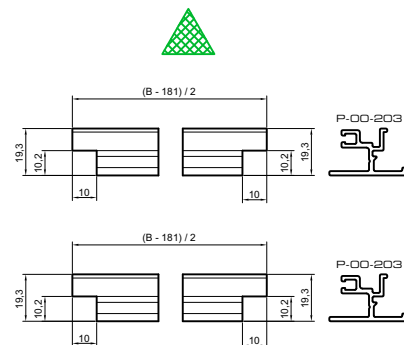
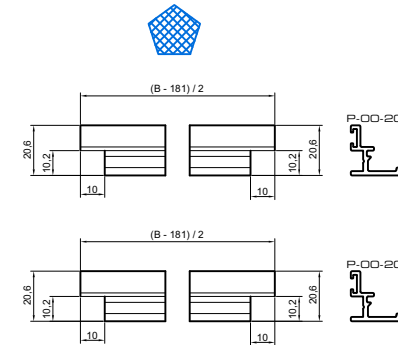

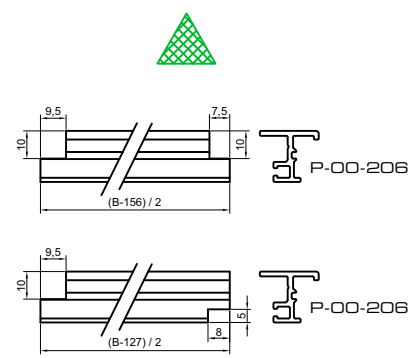
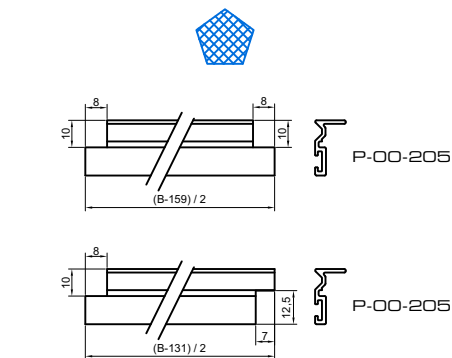
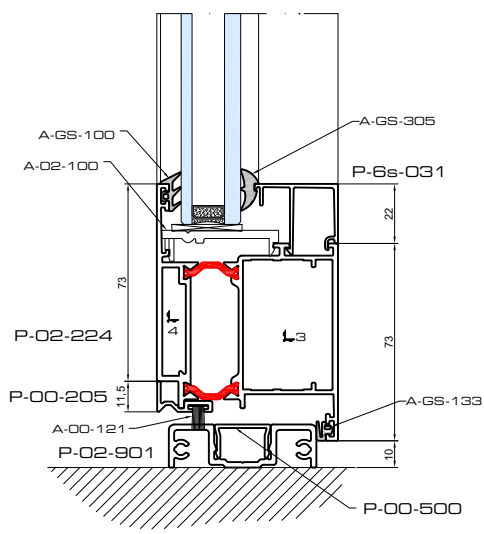
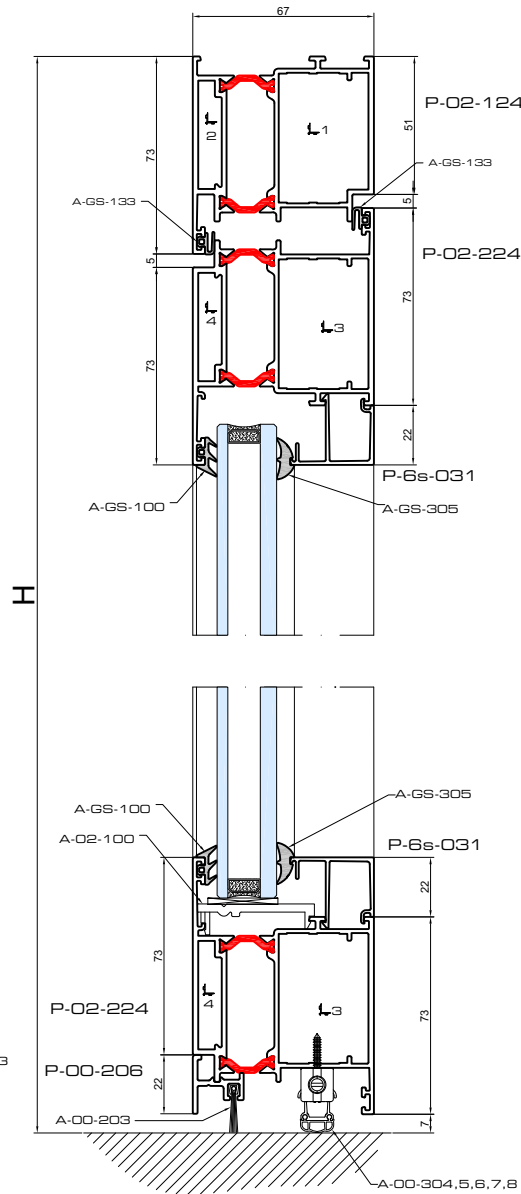
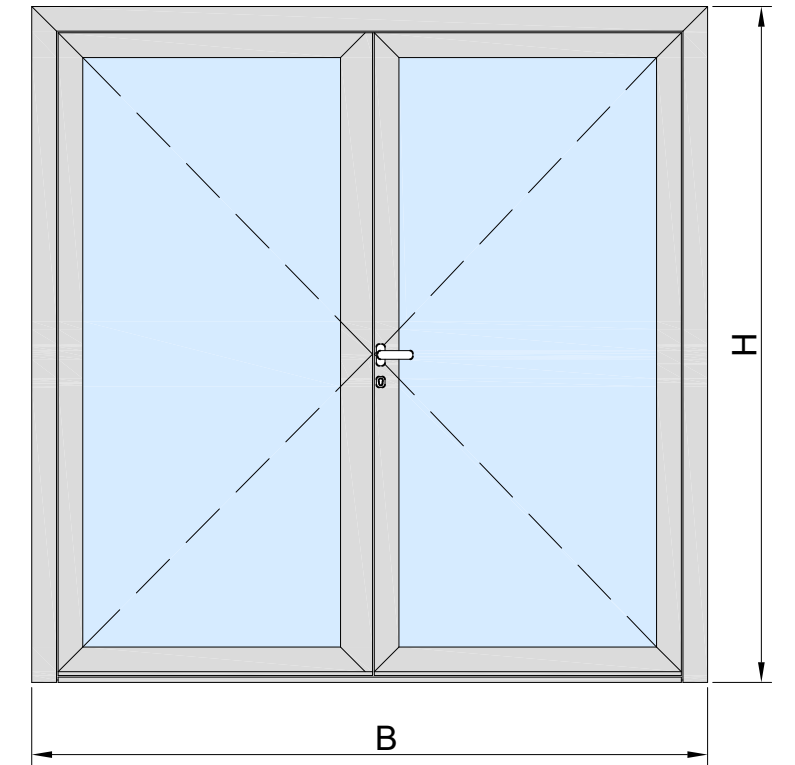

		B	#	H	#
P-02-124		B	1	-	-
P-02-124		-	-	H	1/1
P-02-224		(B - 95) / 2	4	▲ H - 63	3
				● H - 66	3
P-02-225		-	-	▲ H - 63	1
				● H - 66	1
● P-02-901		B - 126	1	-	-
● P-00-500		B - 126	1	-	-
● P-00-205		(B - 159) / 2	1	-	-
		(B - 131) / 2	1	-	-
▲ P-00-206		(B - 156) / 2	1	-	-
		(B - 127) / 2	1	-	-
P-6s-031		(B - 387) / 2	4	▲ H - 253	4
				● H - 256	4
▲ P-00-304,5,6,7,8		(B - 164) / 2	2	-	-

	#
A-02-100	8
A-02-211	1
● A-02-218	1
A-00-105	7
● A-00-210	2
▲ A-00-211	2
A-00-212	1

	#
1 A-PH-4725	2
2 A-PH-4006	2
3 A-PH-4725	8
4 A-PH-4006	8

	#
A-BS-254	1
A-BS-255	1
A-BS-247	1
A-BS-250	1
A-BS-251	2
A-BF-080	6
A-BF-087	6

	B	H
A-GS-100	2B + 2H	
A-GS-133	3B + 4H	
A-GS-305	2B + 2H	
▲ A-00-203	(B - 177) / 2	▲ H - 223
● A-00-121	(B - 177) / 2	● H - 226

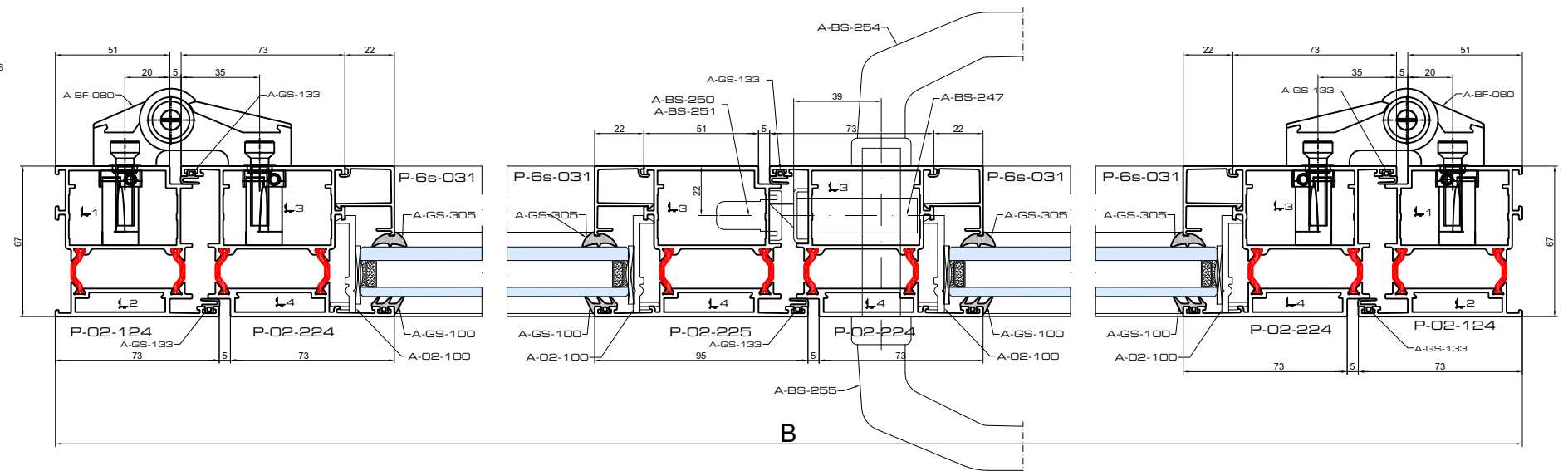

hdcdeur_dubbel_binnen_vlak

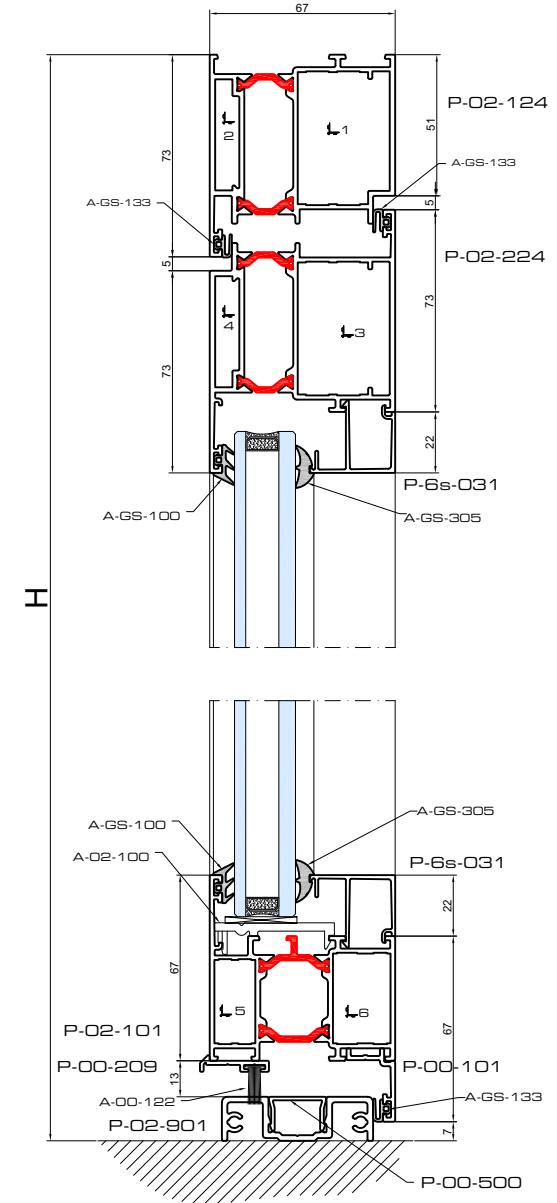

Code	Symbol	B	#	H	#
P-02-124		B	1	-	-
P-02-224		(B - 95) / 2	2	-	-
P-02-225		-	-	H - 85	1
P-02-101		(B - 387) / 2	2	-	-
P-02-901		B - 126	1	-	-
P-00-500		B - 126	1	-	-
P-00-101		(B - 69.5) / 2	1	-	-
P-00-101		(B - 47.5) / 2	1	-	-
P-00-209		(B - 69.5) / 2	1	-	-
P-00-209		(B - 91.5) / 2	1	-	-
P-6s-031		(B - 387) / 2	4	H - 253	4



Code	#	P	LS	T	#
A-02-100	8	-	-	-	-
A-02-211	1	1 A-PH-4725	-	-	2
A-02-218	1	2 A-PH-4006	-	-	2
A-00-105	7	3 A-PH-4725	-	-	4
A-00-212	1	4 A-PH-4006	-	-	4
		5 -	-	A-TV-068	4
		6 -	-	A-TV-002	4

A-GS-100	2B + 2H
A-GS-133	3B + 4H
A-GS-305	2B + 2H
A-00-122	(B - 69.5) / 2
	(B - 91.5) / 2

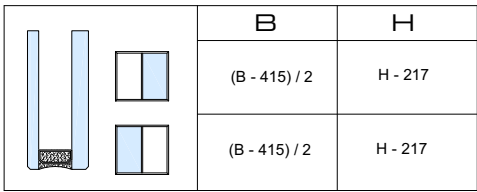

Code	#
A-BS-254	1
A-BS-255	1
A-BS-247	1
A-BS-250	1
A-BS-251	2
A-BF-080	6
A-BF-087	6

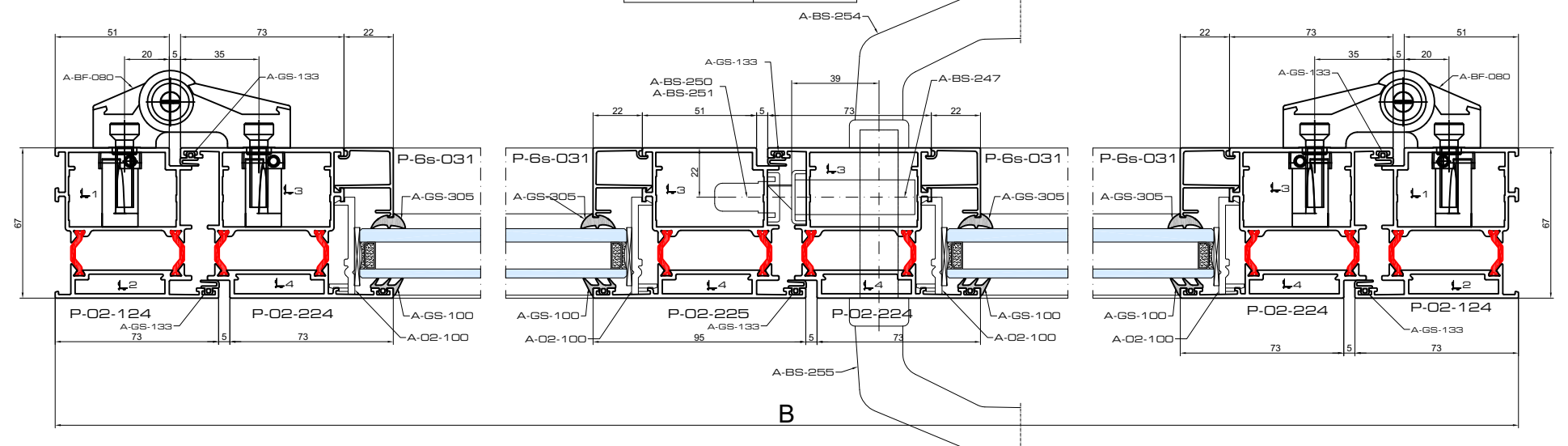
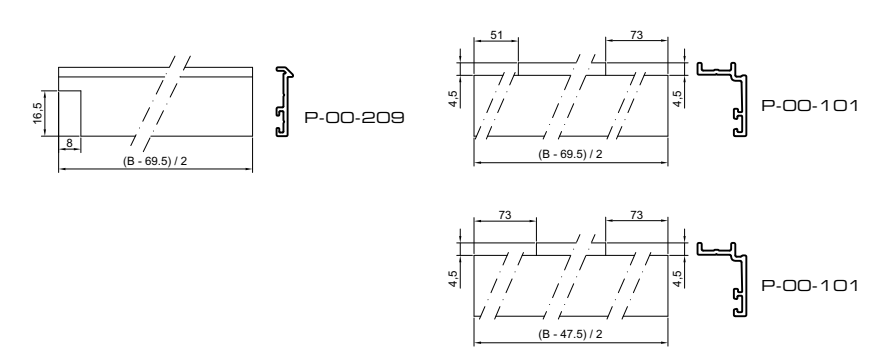
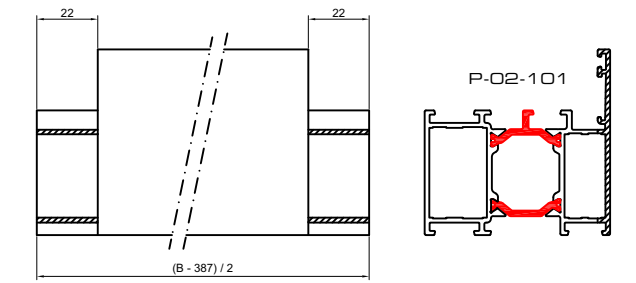
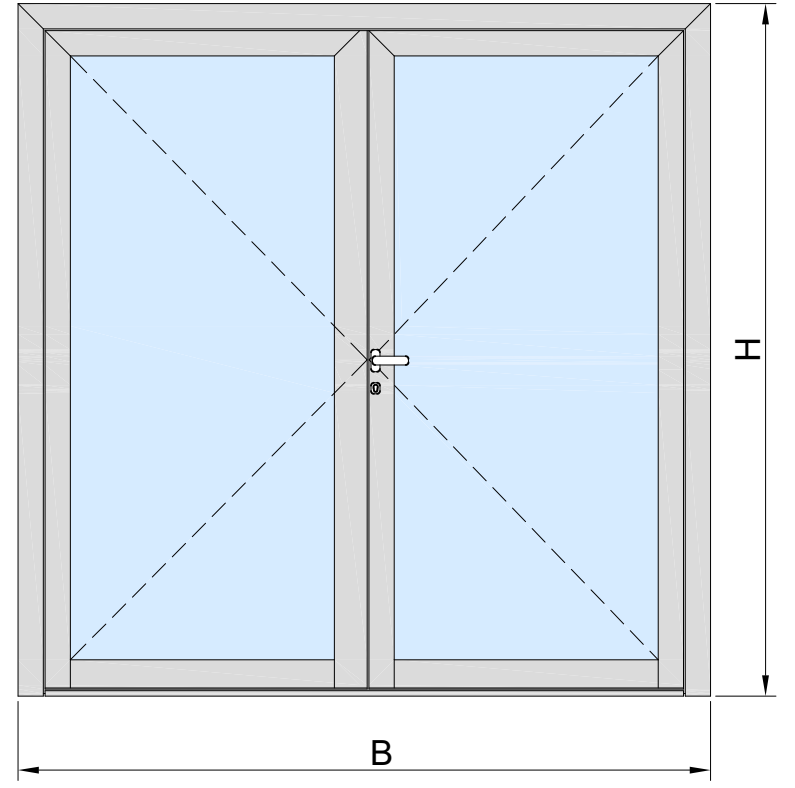

hcdeur_dubbel_binnen_vlak_kader

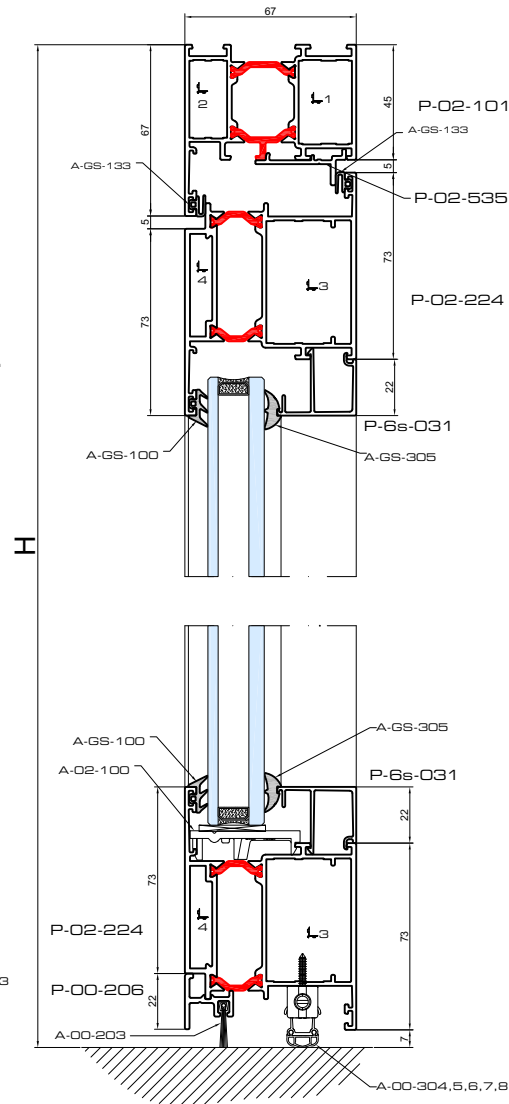

		B	#	H	#
P-02-101		B	1	-	-
P-02-101		-	-	H	1
P-02-224		(B - 105) / 2	4	▲ H - 57	4
P-02-224		-	-	● H - 60	4
P-02-424		-	-	▲ H - 81	1
P-02-535		B - 81.5	1	● H - 102	1
P-02-535		-	-	H - 40.8	2
P-02-901		B - 114.4	1	-	-
P-00-500		B - 114.4	1	-	-
P-00-205		(B - 169) / 2	2	-	-
P-00-206		(B - 163) / 2	2	-	-
P-6s-031		(B - 397) / 2	4	▲ H - 247	4
P-6s-031		-	-	● H - 250	4
P-00-304,5,6,7,8		(B - 174) / 2	2	-	-

	#
A-02-100	8
A-02-213	1
● A-02-219	1
A-02-224	1
A-00-105	7
A-00-210	2
▲ A-00-211	2

			#
1	A-PH-3221	A-SH-3221	2
2	A-PH-3015	A-SH-3015	2
3	A-PH-4725		8
4	A-PH-4006		8

	#
A-BS-254	1
A-BS-255	1
A-BS-247	1
A-BS-256	1
A-BS-257	2
A-BF-080	6
A-BF-087	6

A-GS-100	2B + 2H
A-GS-133	3B + 4H
A-GS-305	2B + 2H
▲ A-00-203	(B - 181) / 2
● A-00-121	(B - 181) / 2

	B	H
	(B - 425) / 2	▲ H - 217
	-	● H - 220
	(B - 425) / 2	▲ H - 217
	-	● H - 220

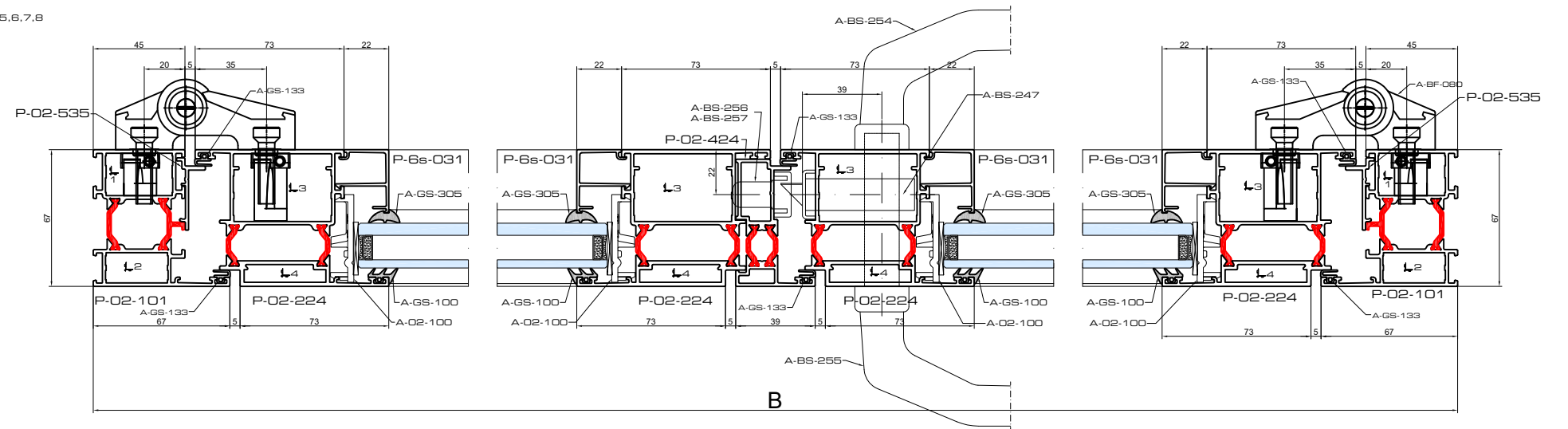
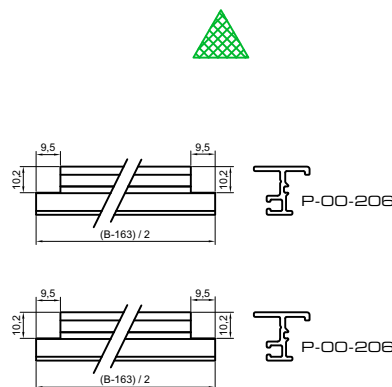
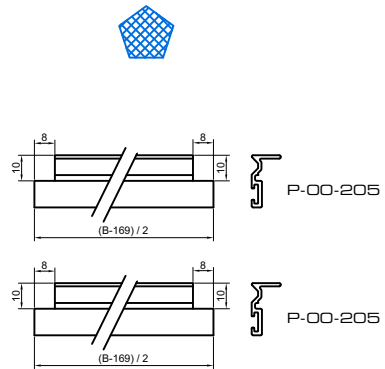
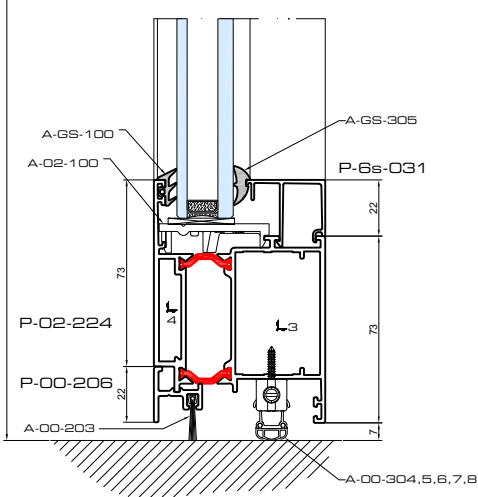
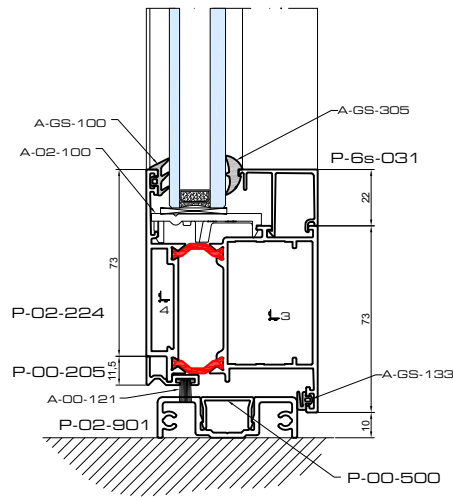
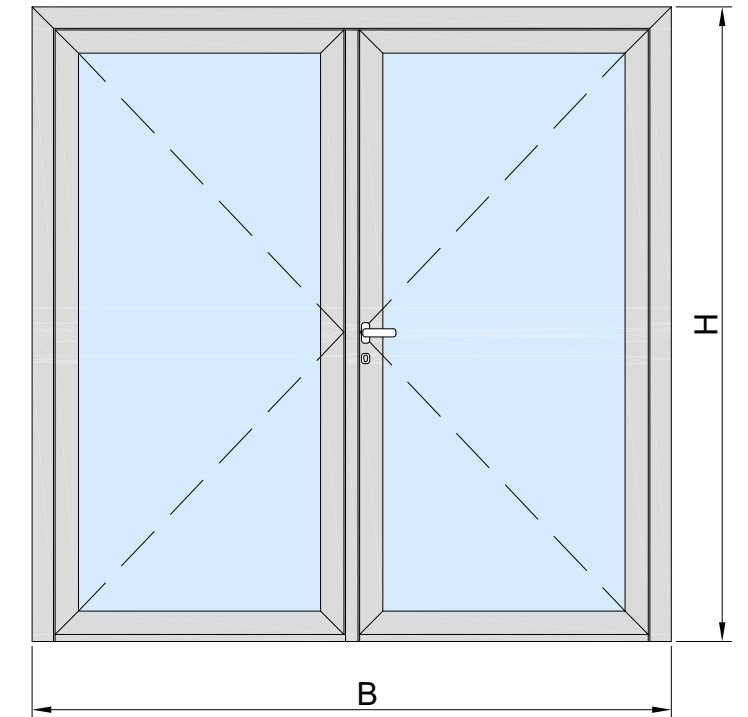

hdeur_dubbel_binnen_vlak_vleugel

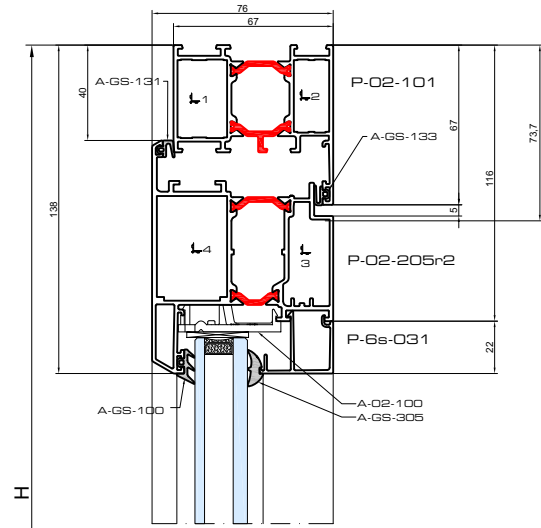
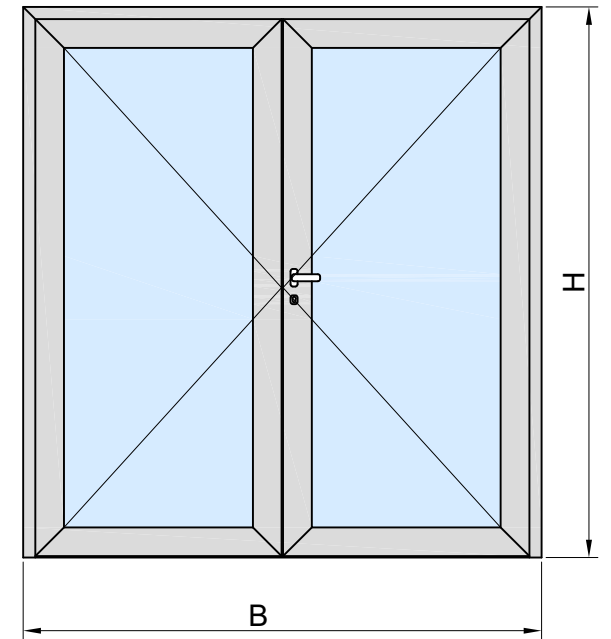

		B	#	H	#
P-02-101		B	1	-	-
P-02-101		-	-	H	1
P-02-205r2		(B - 85) / 2	4	▲ H - 47	4
				◆ H - 49	4
P-02-400		-	-	H - 81	1
▲ P-02-900		B - 94	1	-	-
▲ P-00-500		B - 94	1	-	-
▲ P-00-203		(B - 180) / 2	2	-	-
◆ P-00-204		(B - 180) / 2	1	-	-
P-6s-031		(B - 388) / 2	4	▲ H - 242.6	4
				◆ H - 244.6	4
▲ A-00-204,5,6,7,8		(B - 171) / 2	2	-	-

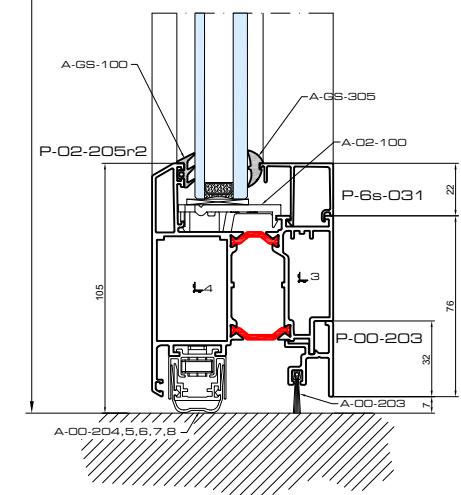
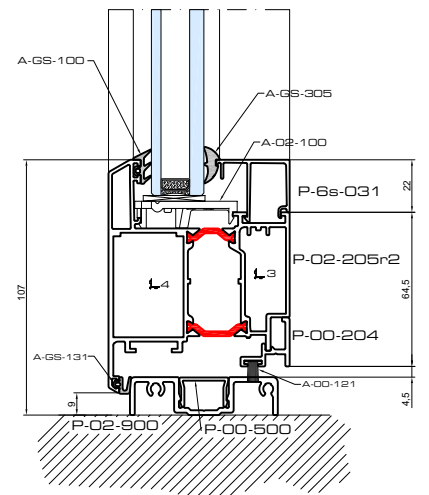

	#
A-00-105	12
A-02-100	8
A-02-203	1
▲ A-02-205	1
◆ A-02-900	1

	P	S	#
1	A-PH-3015	A-SH-3015	2
2	A-PH-3221	A-SH-3221	2
3	A-PH-4206		8
4	A-PH-4229	A-SH-4229	8

	#
A-BS-254	1
A-BS-255	1
A-BS-242	1
A-BS-250	1
A-BS-251	2
A-BF-063	1
A-BF-063	6

▲ A-GS-131	B + 3H
▲ A-GS-133	B + 4H
▲ A-GS-100	2B + 4H
▲ A-GS-305	2B + 4H
▲ A-00-203	(B - 177) / 2
◆ A-00-121	(B - 177) / 2

	B	H
	(B - 416) / 2	▲ H - 212.6
		◆ H - 214.6
	(B - 416) / 2	▲ H - 212.6
		◆ H - 214.6

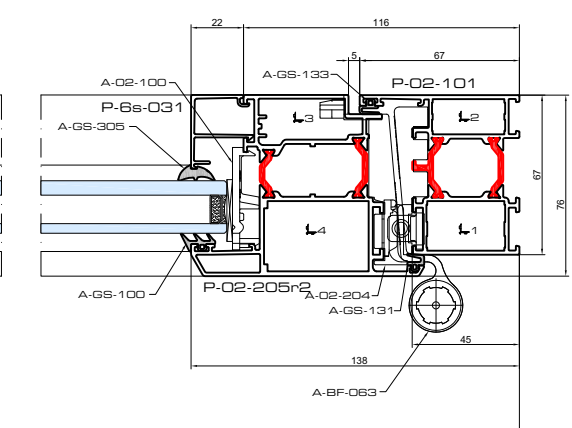
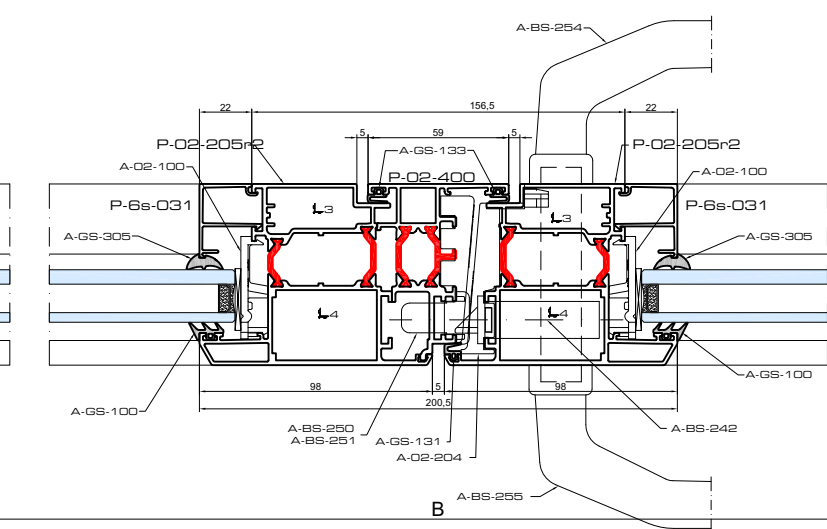
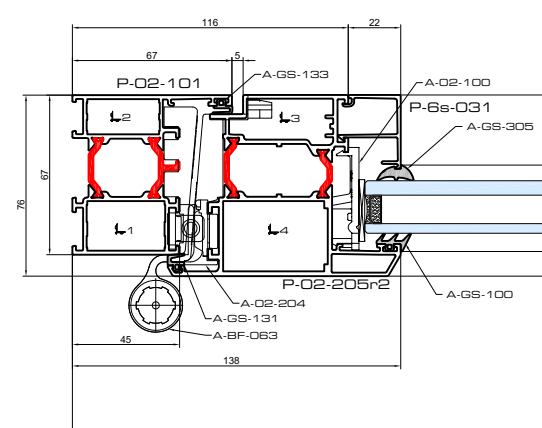
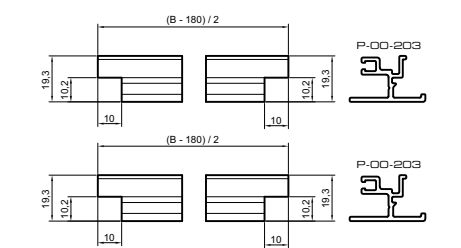
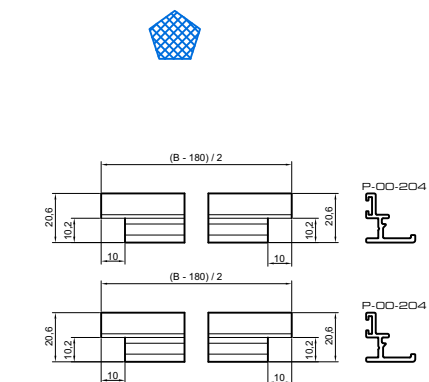

dubbele_deur_buiten_hc

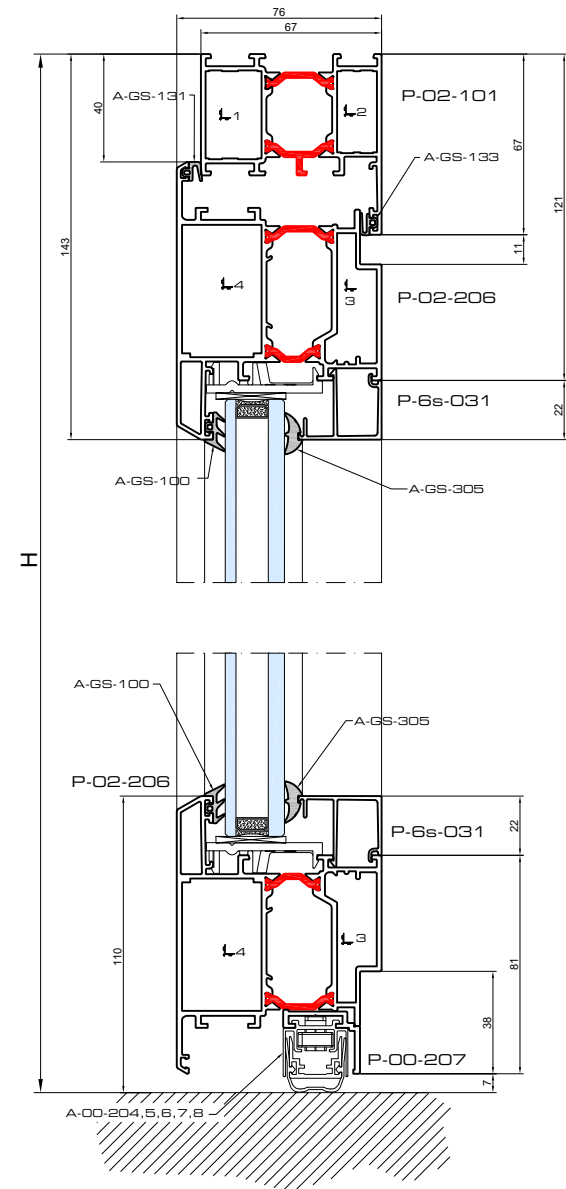

		B	#	H	#
P-02-101		B	1	-	-
P-02-101		-	-	H	1
P-02-206		(B - 85) / 2	4	H - 47	4
P-02-400		-	-	H - 79	1
P-00-207		(B - 177) / 2	2	-	-
P-6s-031		(B - 409) / 2	4	H - 209	4
A-00-204,5,6,7,8		(B - 171) / 2	2	-	-



	#
A-00-105	12
A-02-100	8
A-02-203	1
A-02-205	1

	P	S	#
1	A-PH-3015	A-SH-3015	2
2	A-PH-3221	A-SH-3221	2
3	A-PH-4707		8
4	A-PH-4730	A-SH-4730	8

	#
A-BS-254	1
A-BS-255	1
A-BS-237	1
A-BS-250	1
A-BS-251	2
A-BF-063	6

A-GS-131	B + 3H
A-GS-133	B + 4H
A-GS-100	2B + 4H
A-GS-305	2B + 4H

	B	H
	(B - 437) / 2	H - 223
	(B - 437) / 2	H - 223

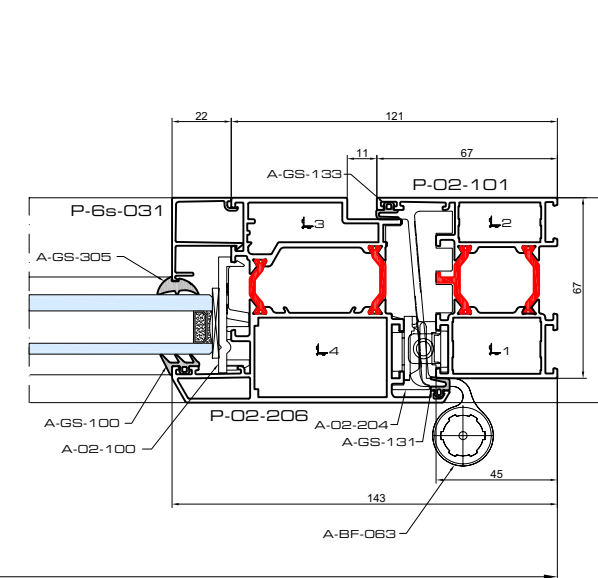
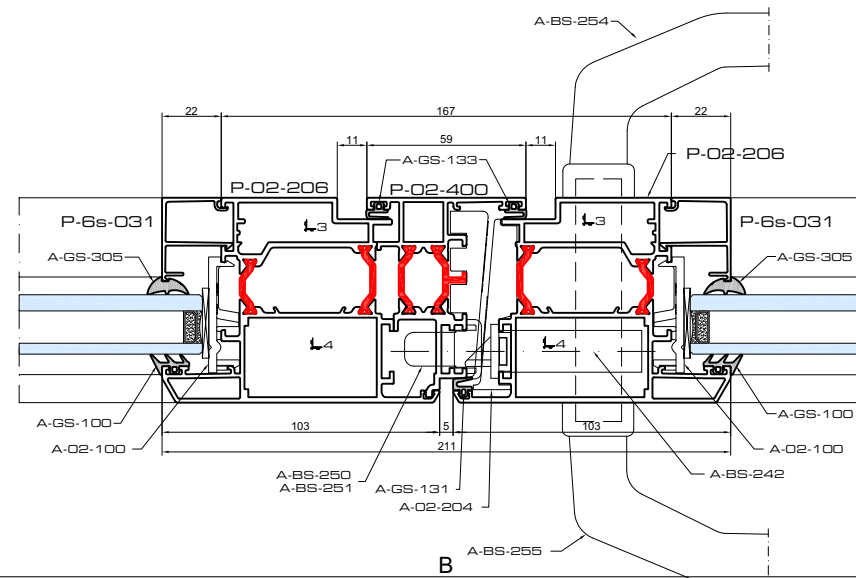
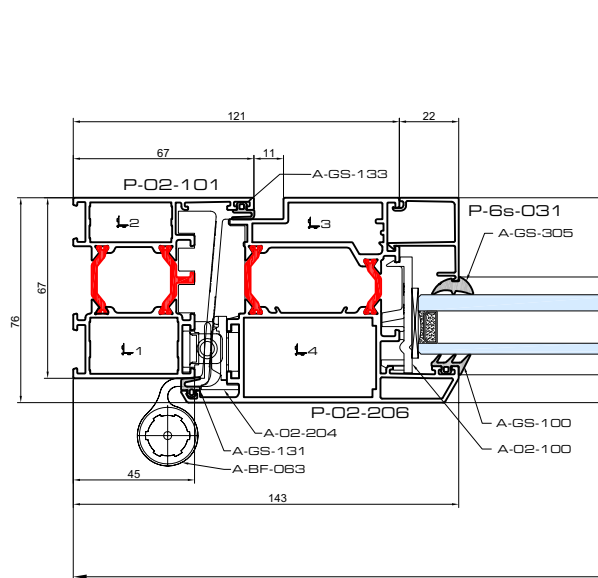
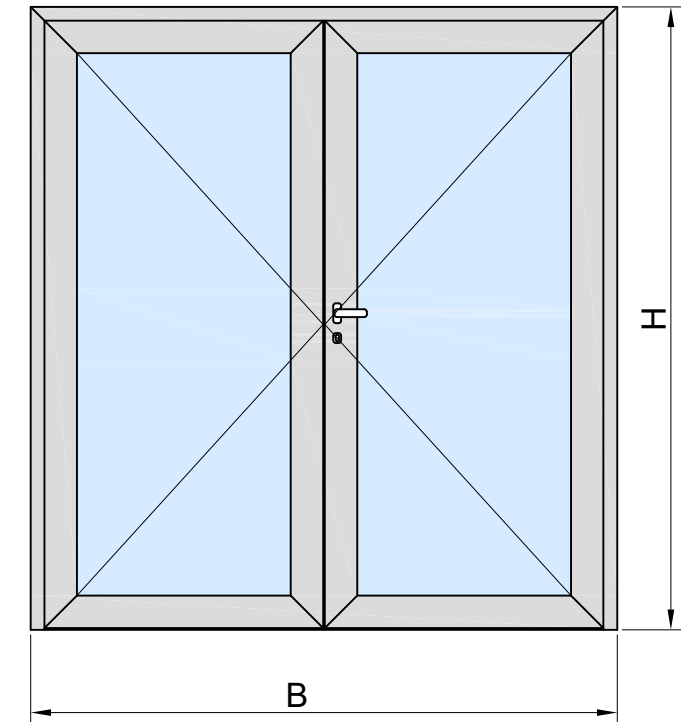

dubbele_deur_buiten_hc_206

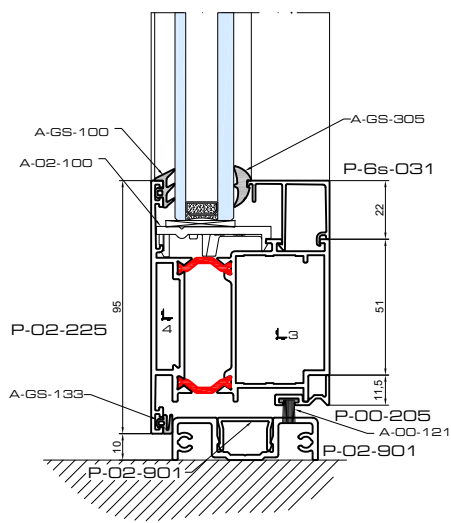
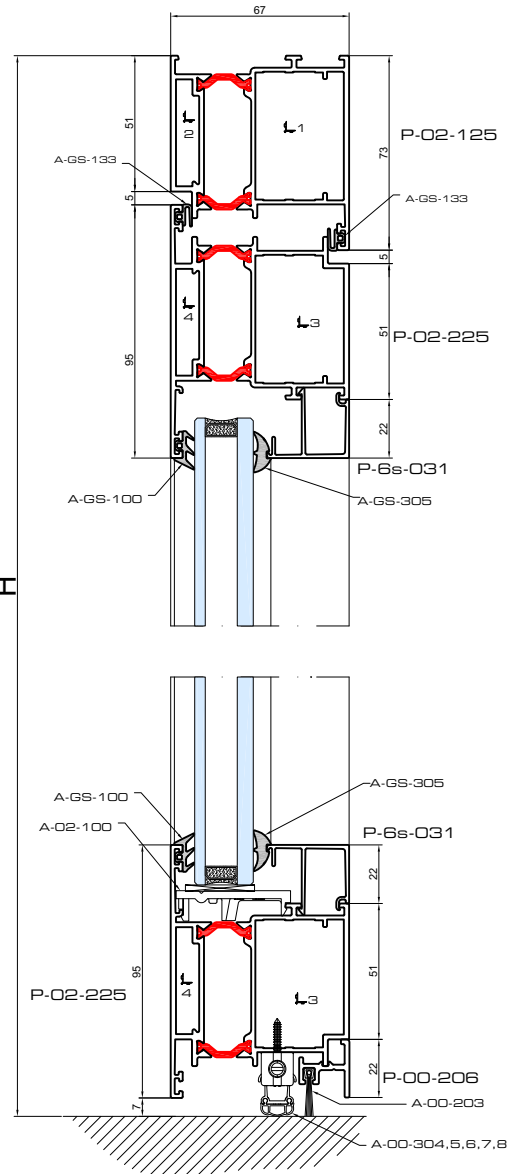
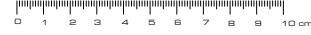

		B	#	H	#
P-02-125		B	1	-	-
P-02-125		-	-	H	1
P-02-225		(B - 117) / 2	4	▲ H - 63	4
P-02-425		-	-	● H - 66	4
P-02-901		B - 126	1	▲ H - 87	1
P-00-500		B - 126	1	● H - 108	1
P-00-205		(B - 181) / 2	2	-	-
P-00-206		(B - 175) / 2	2	-	-
P-6s-031		(B - 409) / 2	4	▲ H - 253	4
P-00-304,5,6,7,8		(B - 186) / 2	2	● H - 256	4

	#
A-02-100	8
A-02-215	1
A-02-218	1
A-02-225	1
A-00-105	7
A-00-210	2
A-00-211	2

	P	S	#
1	A-PH-4725		2
2	A-PH-4006		2
3	A-PH-4725		8
4	A-PH-4006		8

	#
A-BS-254	1
A-BS-255	1
A-BS-247	1
A-BS-256	1
A-BS-257	2
A-BF-080	6
A-BF-087	6

A-GS-100	2B + 2H
A-GS-133	3B + 4H
A-GS-305	2B + 2H
A-00-203	(B - 193) / 2
A-00-121	(B - 193) / 2

	B	H
	(B - 437) / 2	▲ H - 223
	(B - 437) / 2	● H - 226
	(B - 437) / 2	▲ H - 223
	(B - 437) / 2	● H - 226

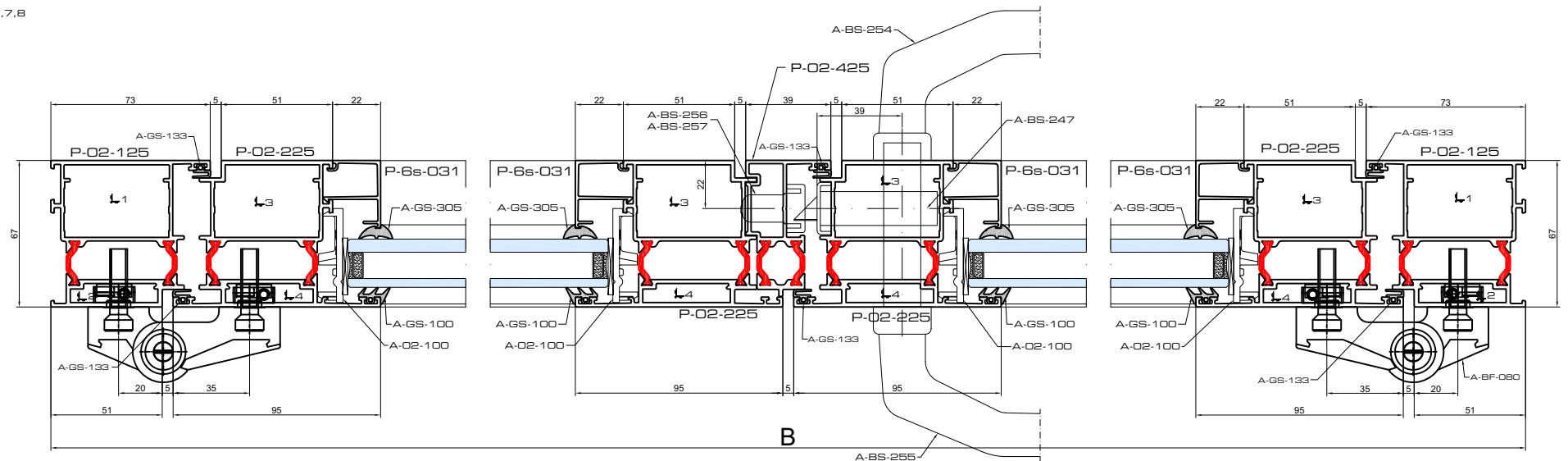
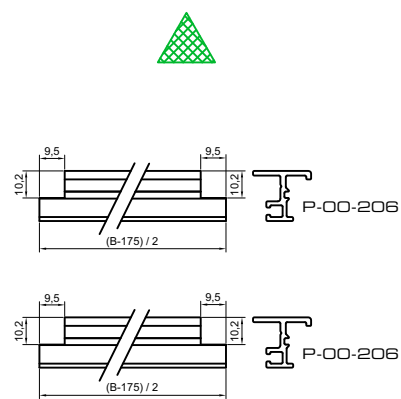
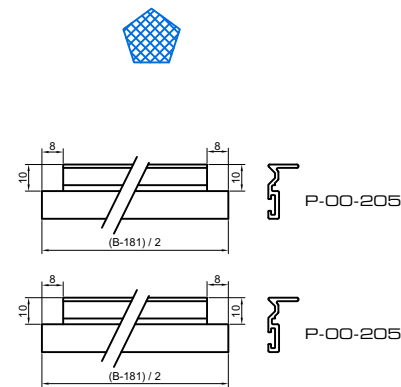
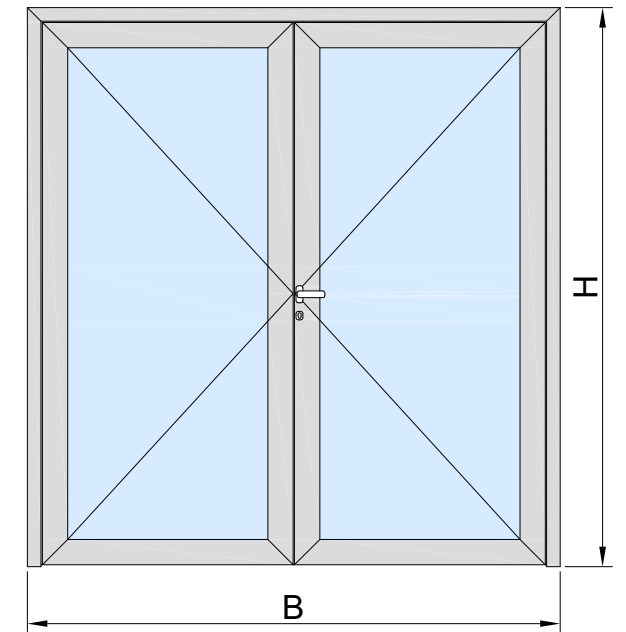

hcdeur_dubbel_buiten_vlak

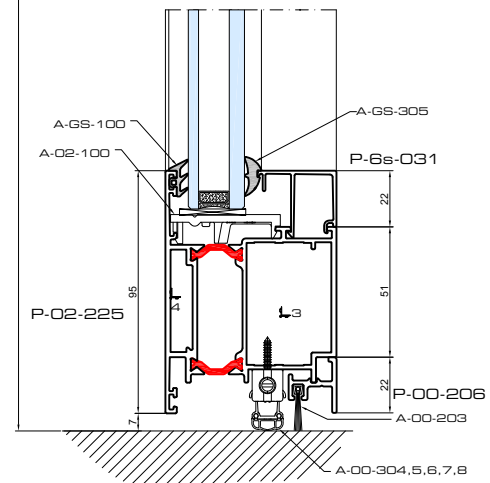
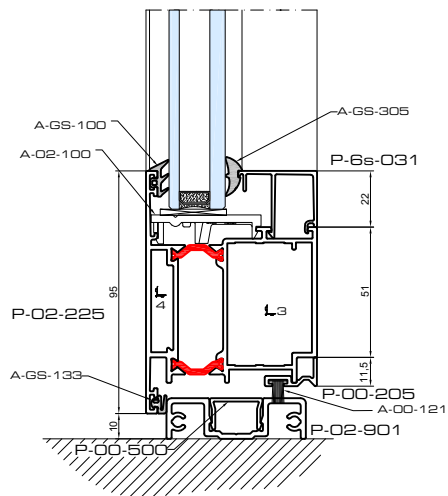
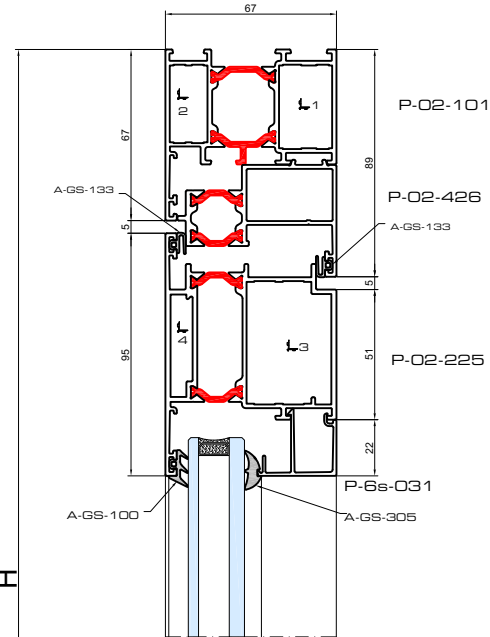

		B	#	H	#
P-02-101		B	1	-	-
P-02-101		-	-	H	1
P-02-225		B - 149	4	▲ H - 79	4
P-02-425		-	-	● H - 82	4
P-02-426		-	-	▲ H - 103	1
P-02-426		B - 90	1	● H - 130	1
P-02-426		-	-	H - 45	2
P-02-901		B - 158	1	-	-
P-00-500		B - 158	1	-	-
P-00-205		(B - 213) / 2	2	-	-
P-00-206		(B - 207) / 2	2	-	-
P-6s-031		(B - 441) / 2	4	▲ H - 269	4
P-00-304,5,6,7,8		(B - 218) / 2	2	● H - 272	4

	#
A-02-100	8
A-02-217	1
A-02-220	1
A-02-225	1
A-00-105	7
A-00-210	2
A-00-211	2

	P	S	#
1	A-PH-3221	A-SH-3221	2
2	A-PH-3015	A-SH-3015	2
3	A-PH-4725		8
4	A-PH-4006		8

	#
A-BS-254	1
A-BS-255	1
A-BS-247	1
A-BS-256	1
A-BS-257	2
A-BF-081	6
A-BF-087	6

A-GS-100	2B + 2H
A-GS-133	3B + 4H
A-GS-305	2B + 2H
A-00-203	(B - 225) / 2
A-00-121	(B - 225) / 2

	B	H
	(B - 469) / 2	▲ H - 239
	(B - 469) / 2	● H - 242

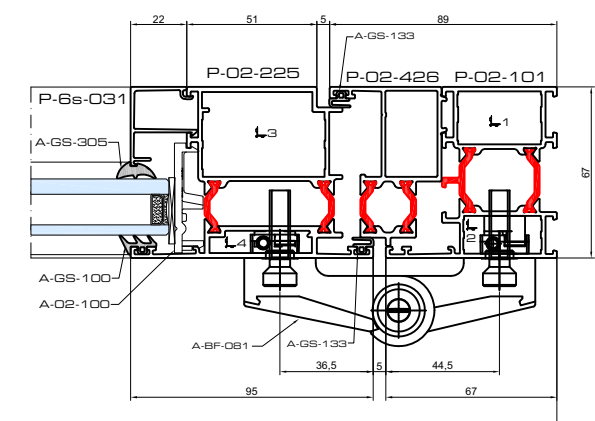
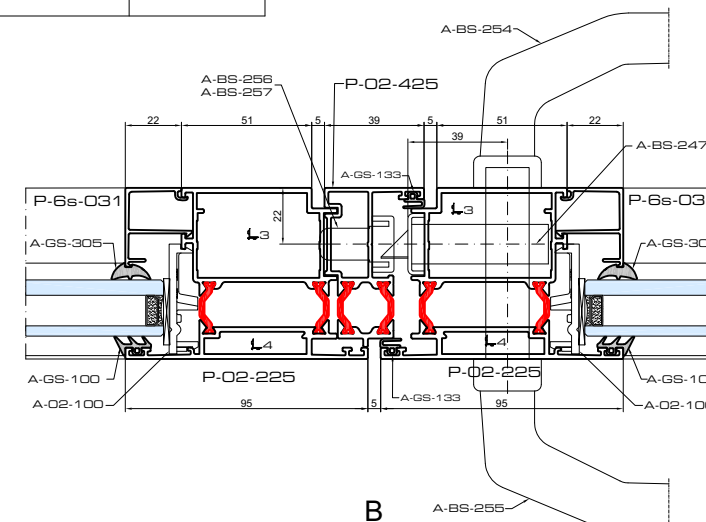
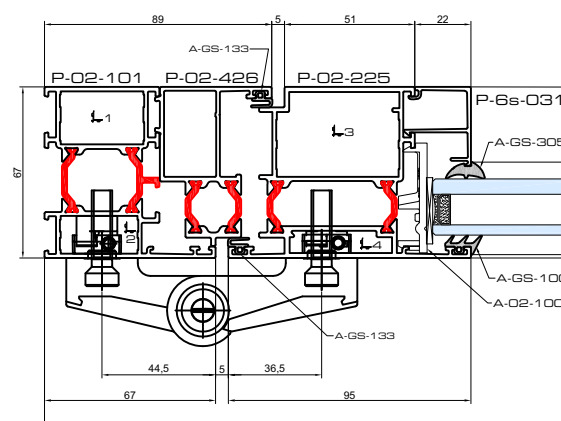
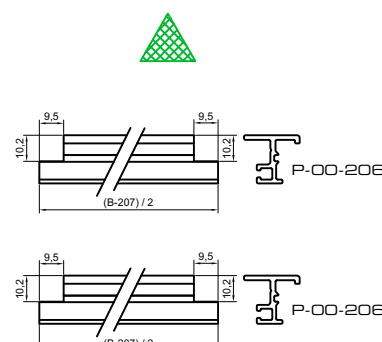
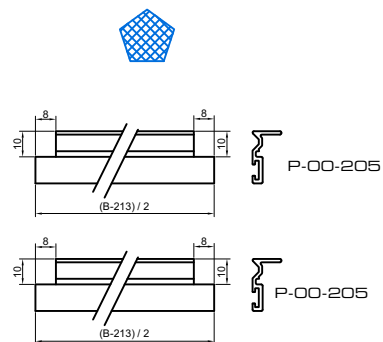
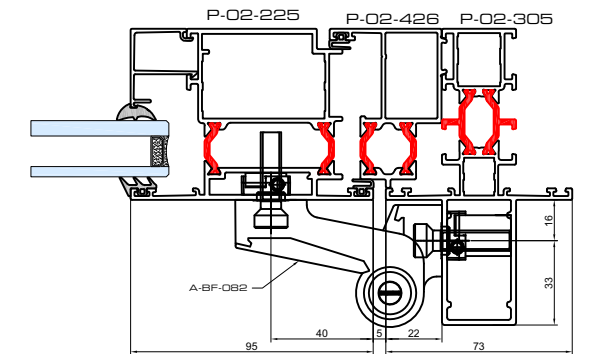
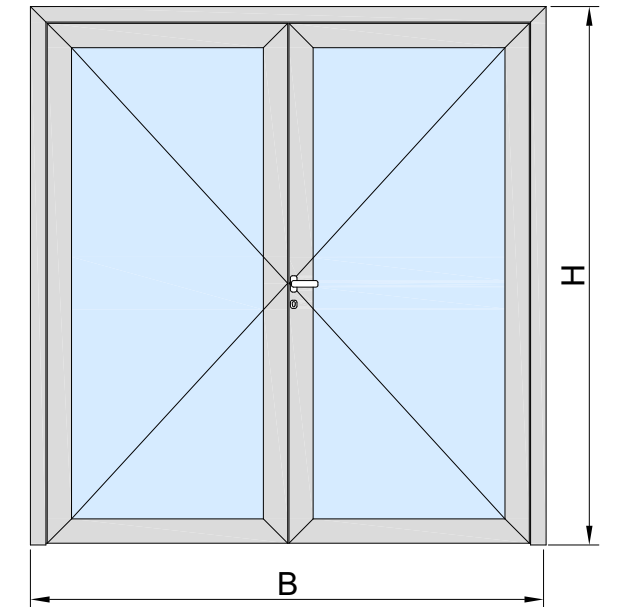

hcdeur_dubbel_buiten_vlak_vleugel

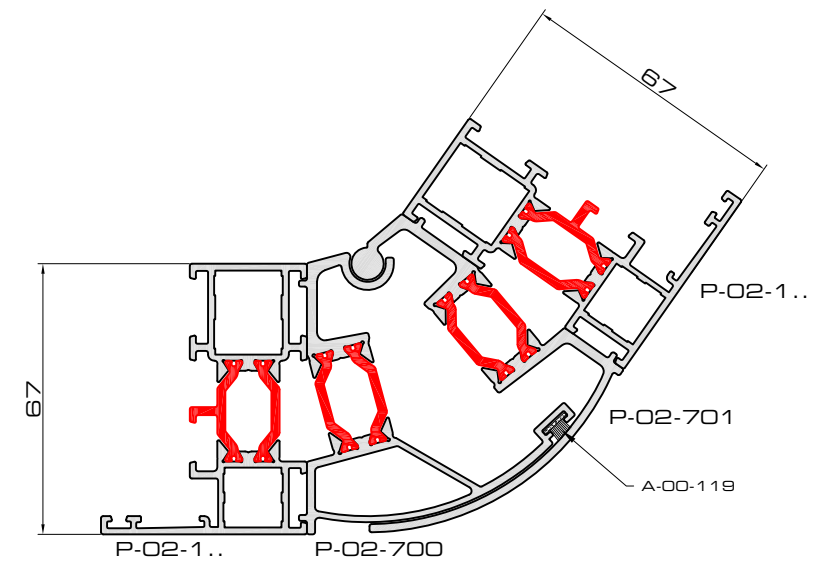
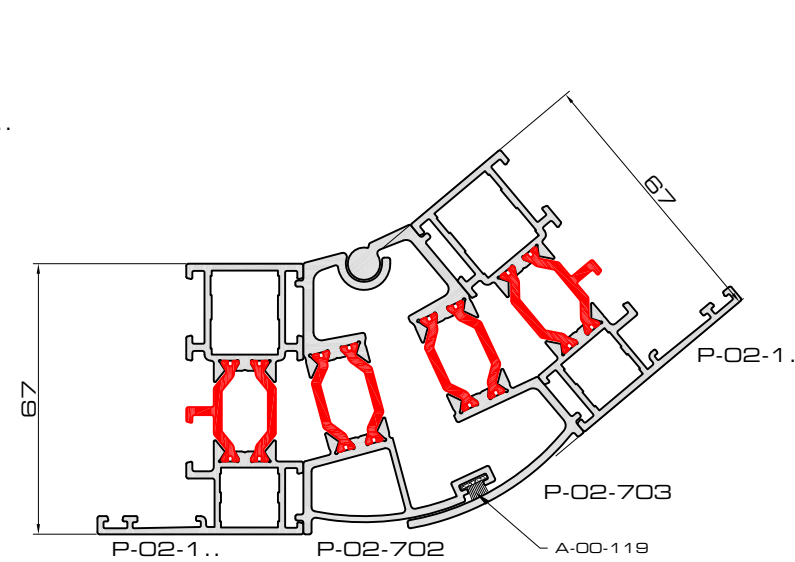
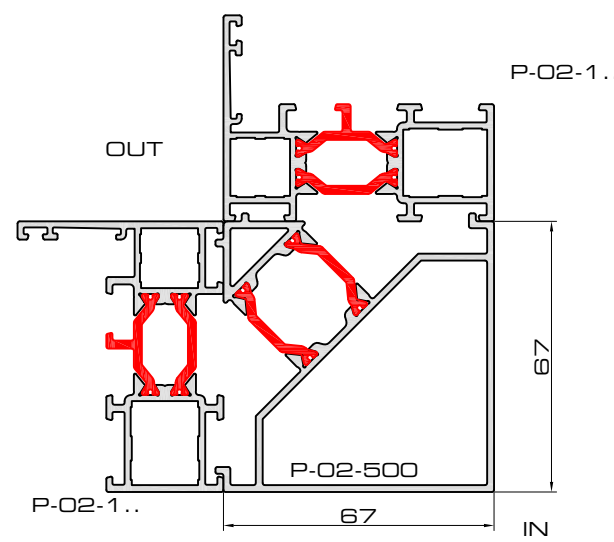
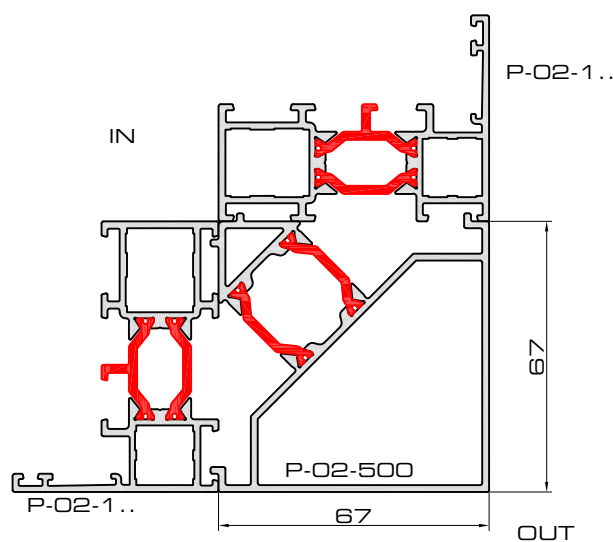
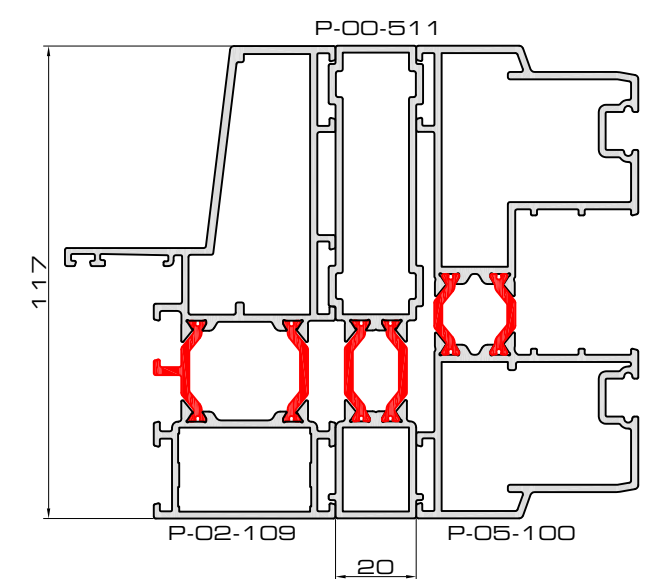
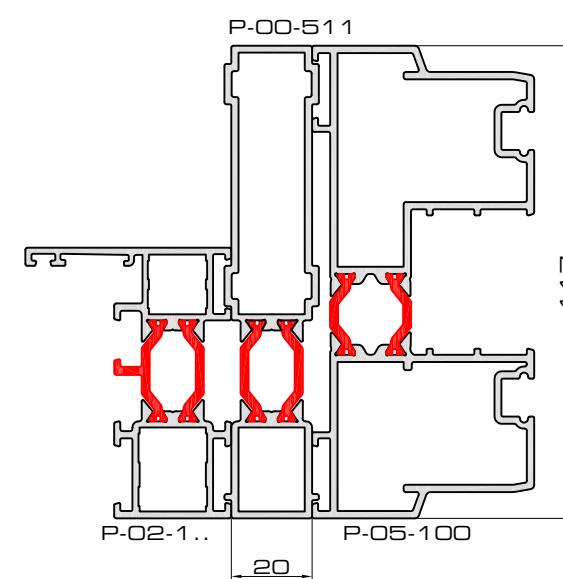
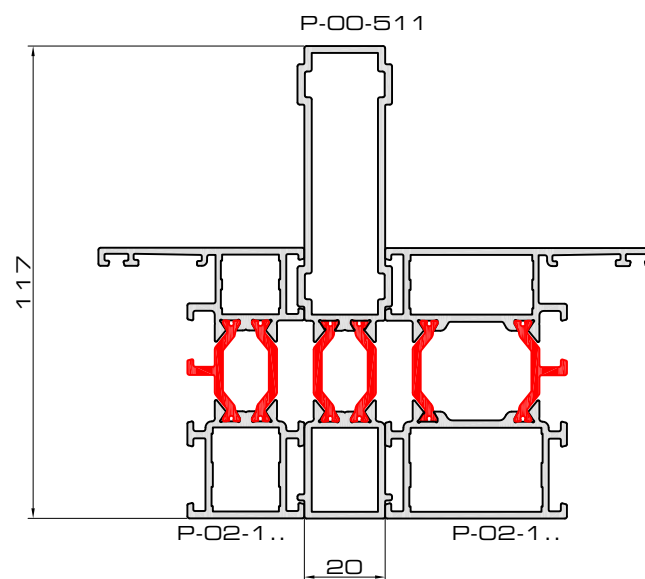
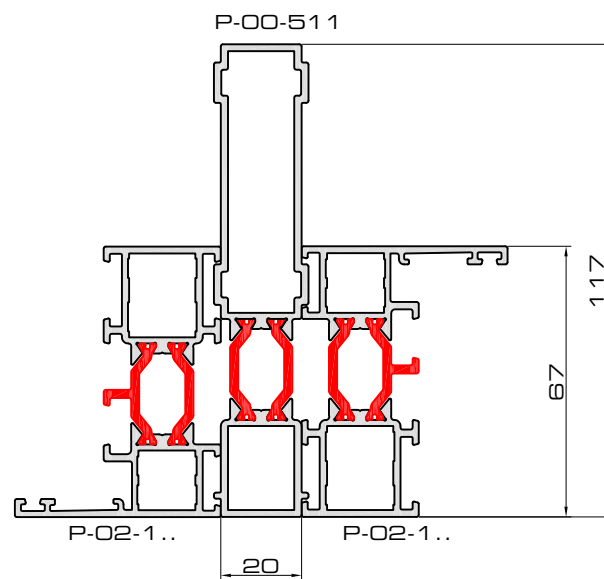
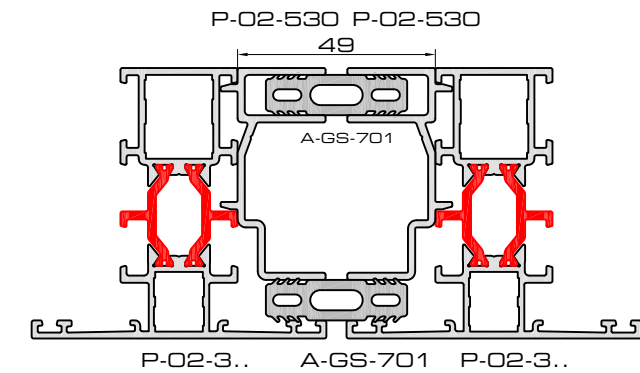
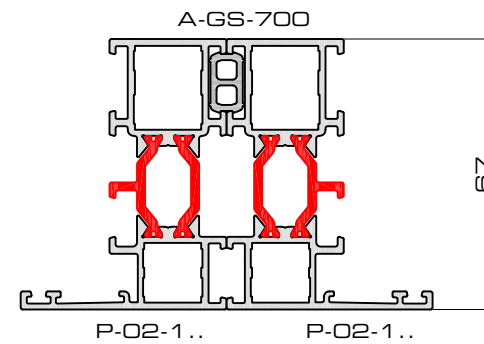
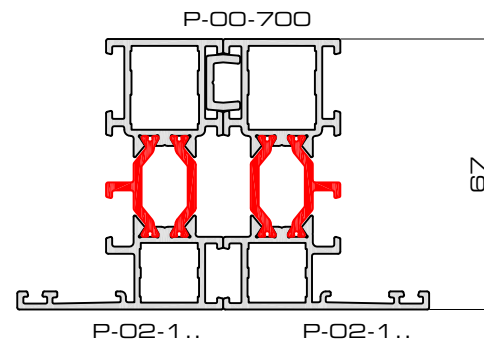
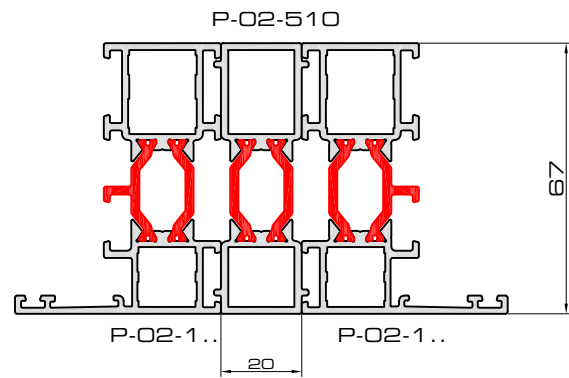

overzichthc

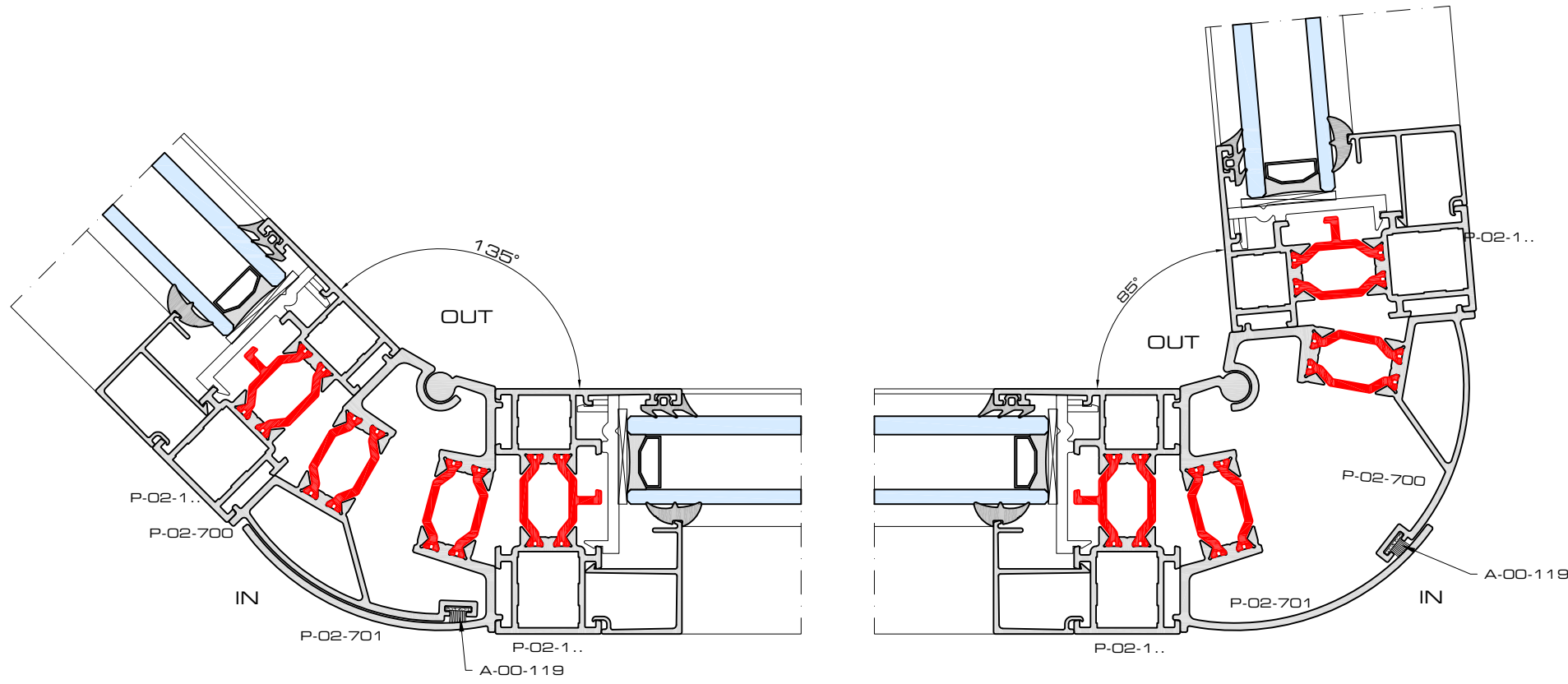

85° < A < 135°

$$X = 15 + \frac{67}{\tan \frac{A}{2}}$$

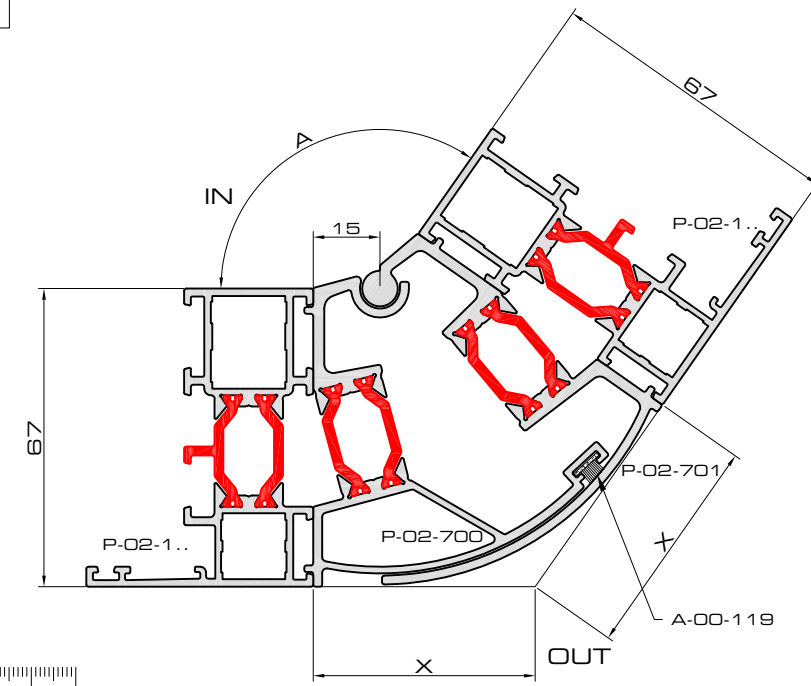
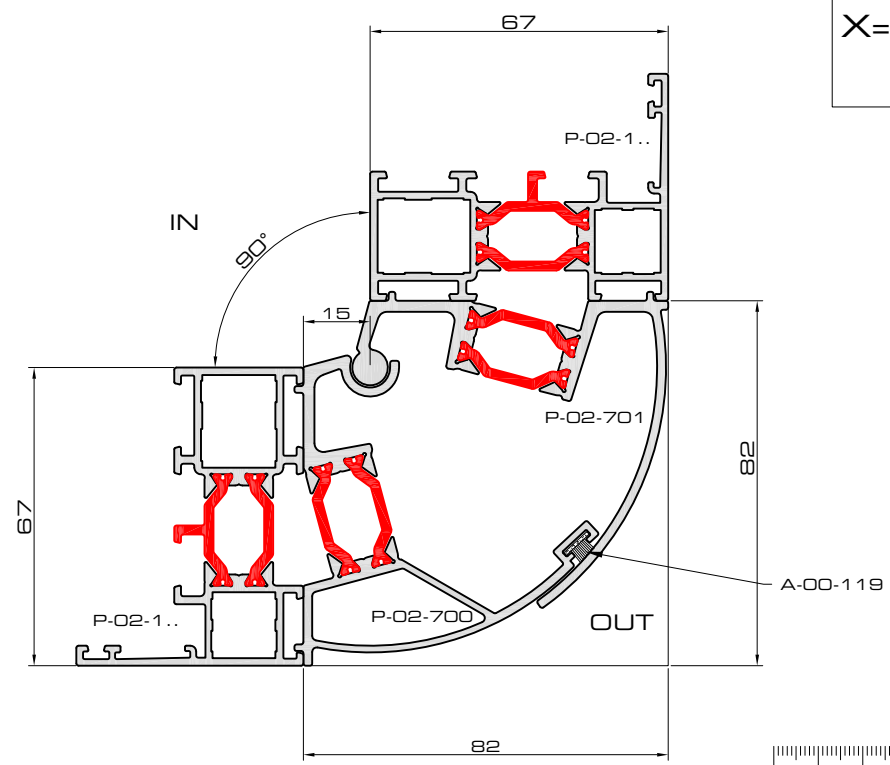

hoek85°tot135°

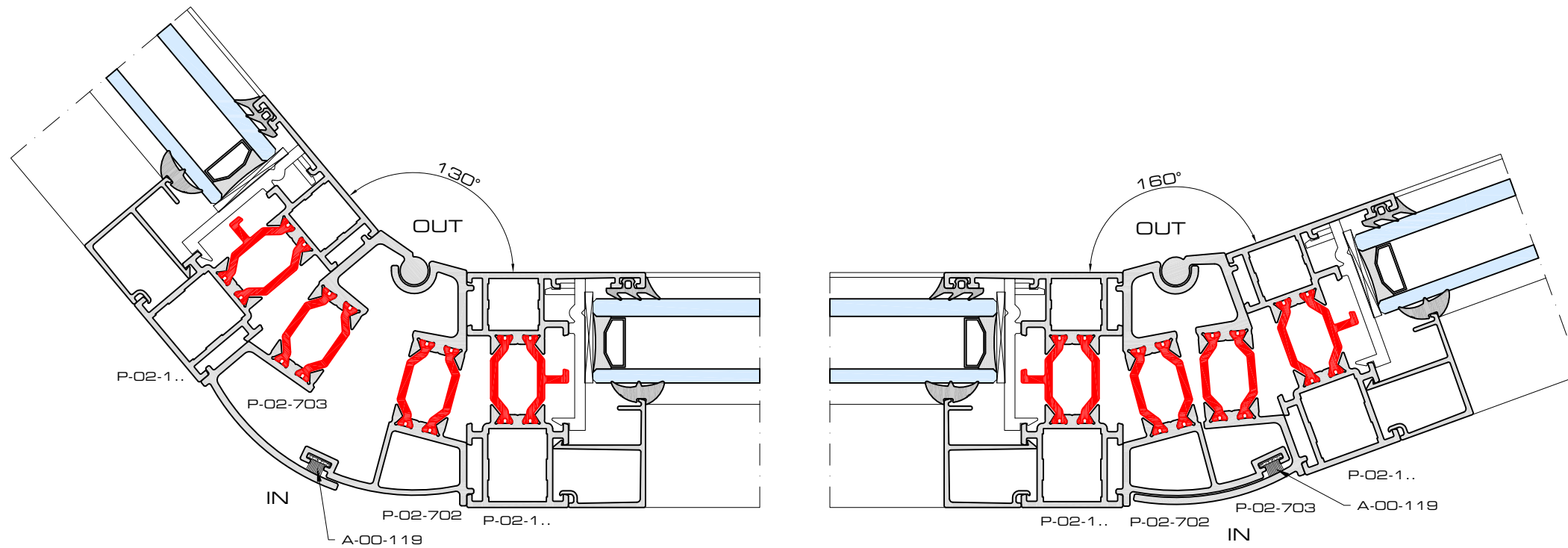

$130^\circ < A < 160^\circ$

$$X = 15 + \frac{67}{\tan \frac{A}{2}}$$

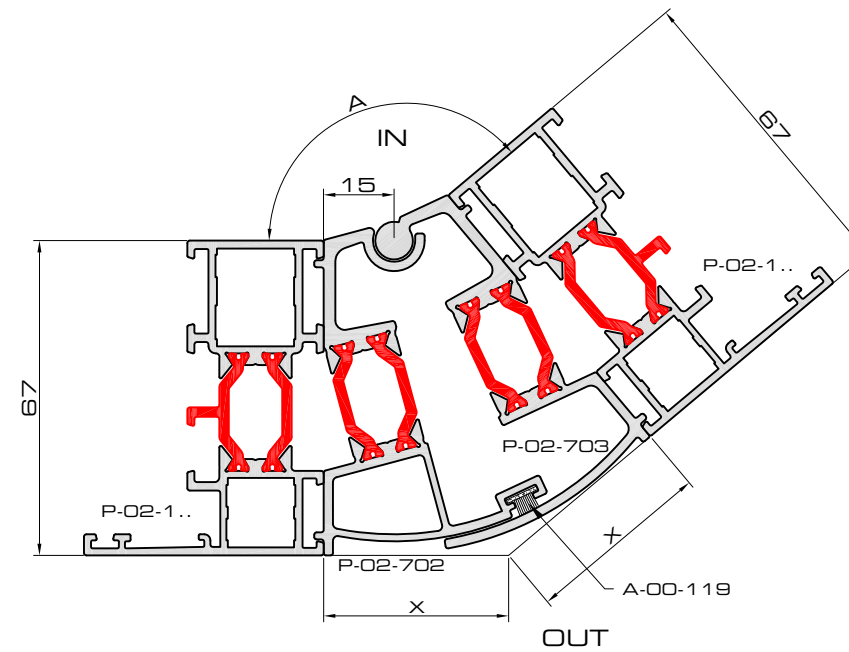
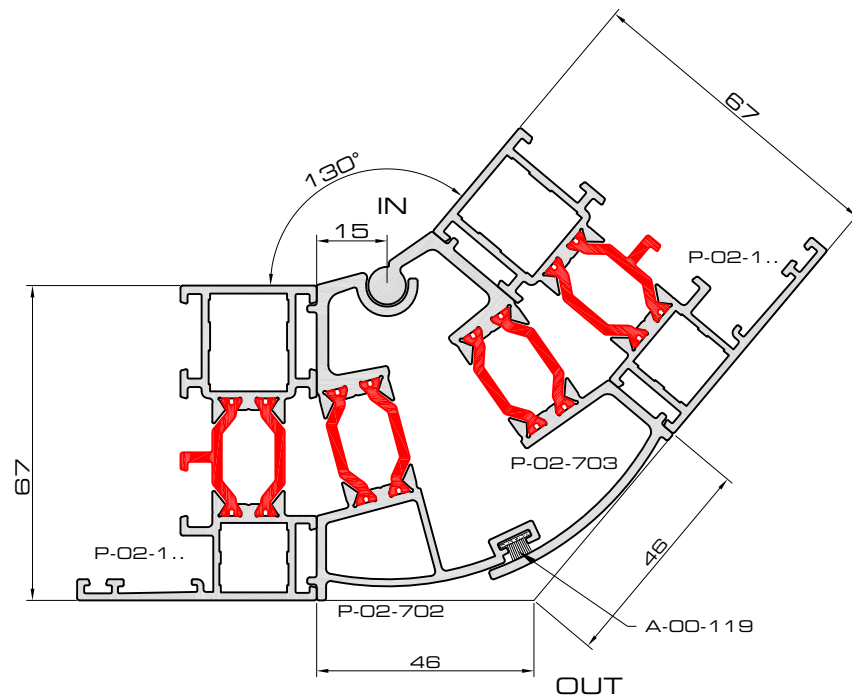

hoek 130° tot 160°

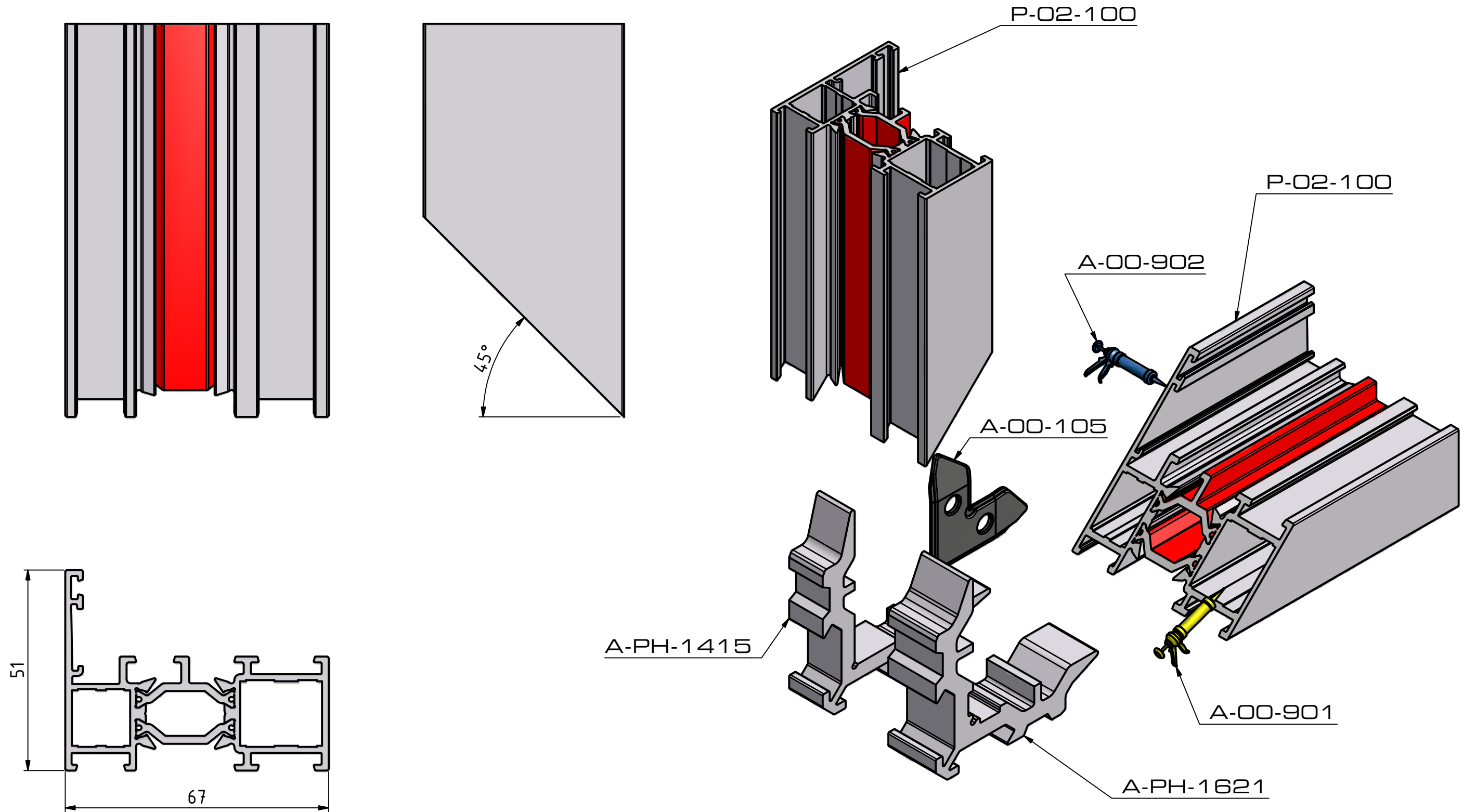

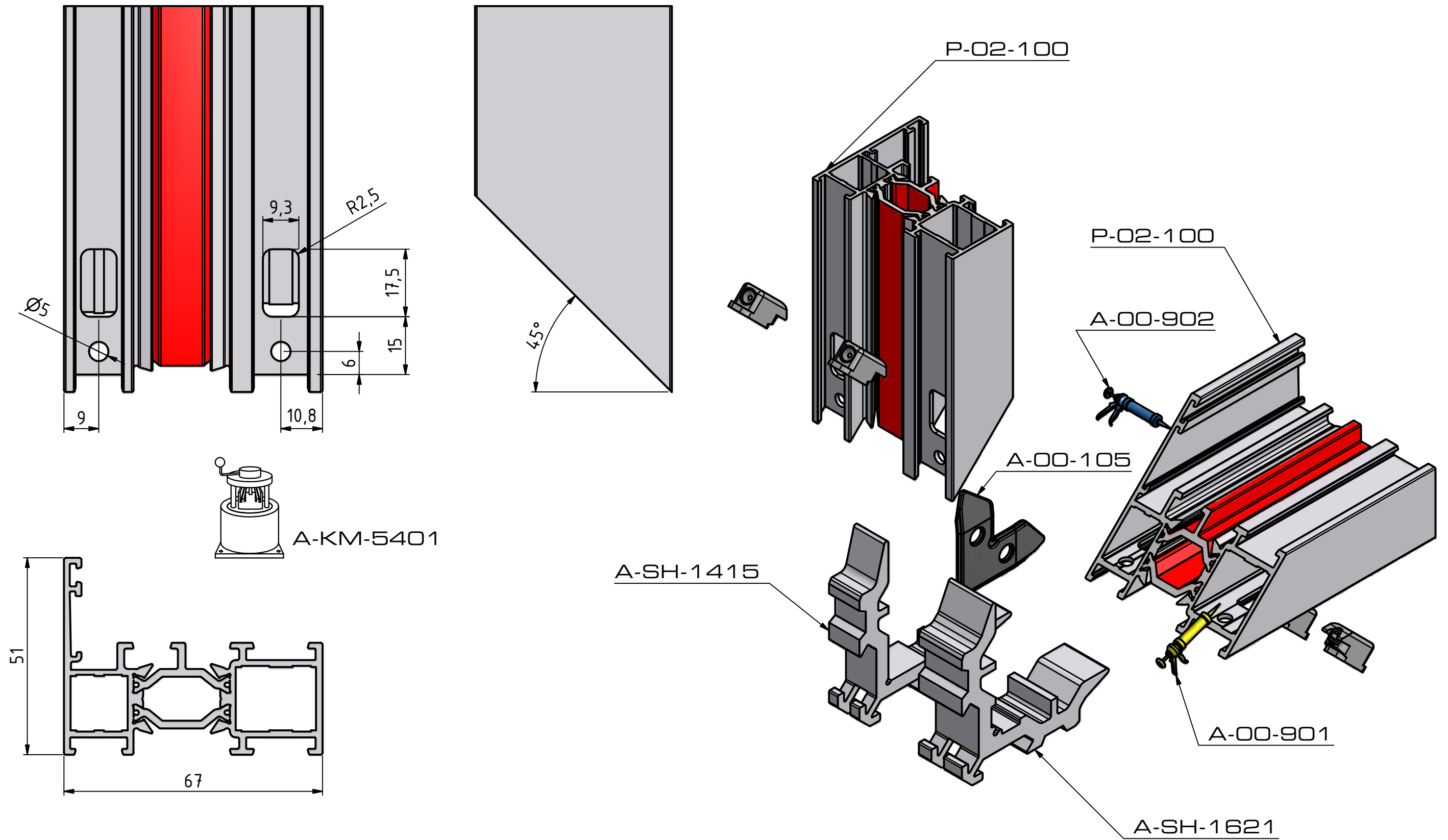

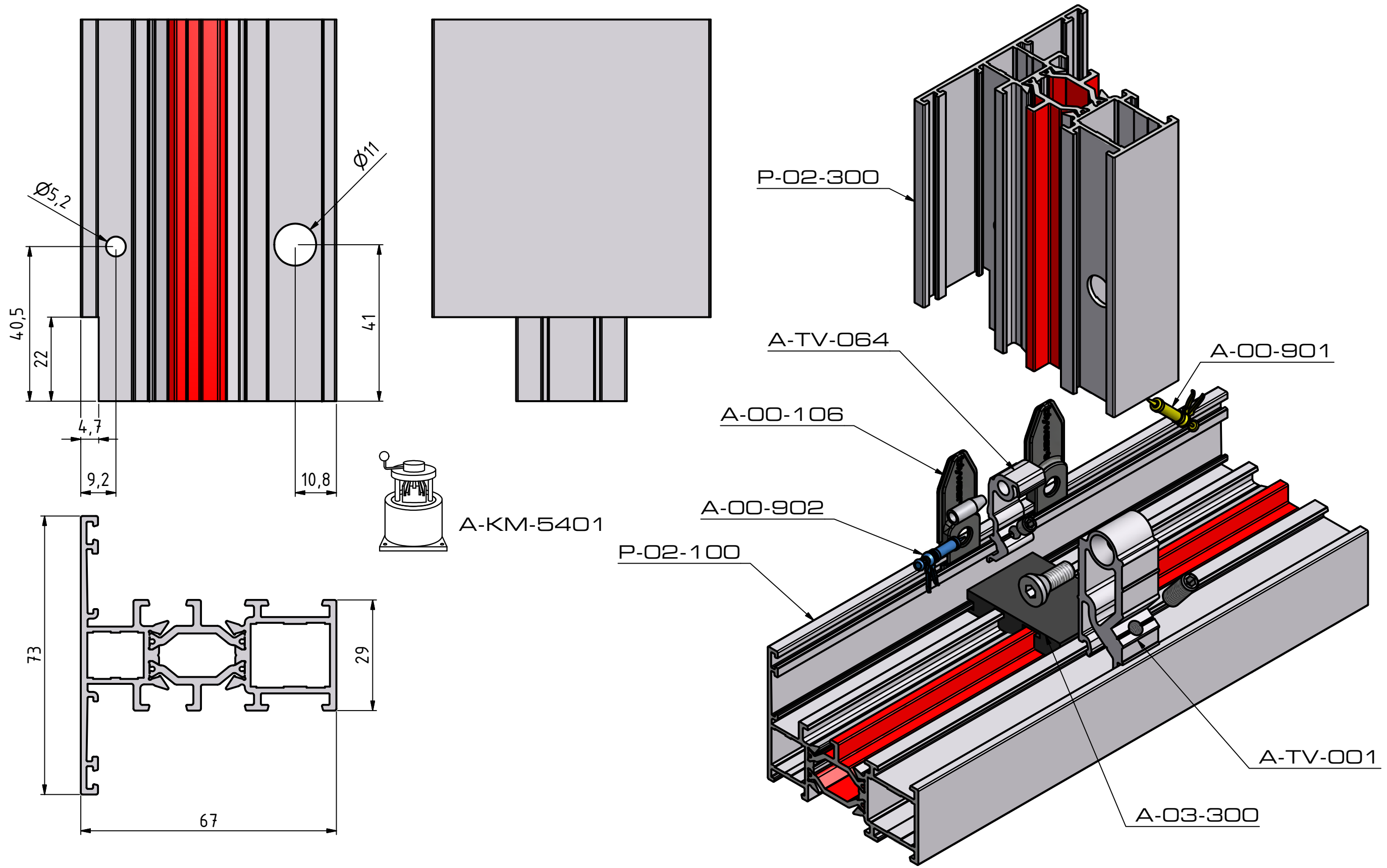

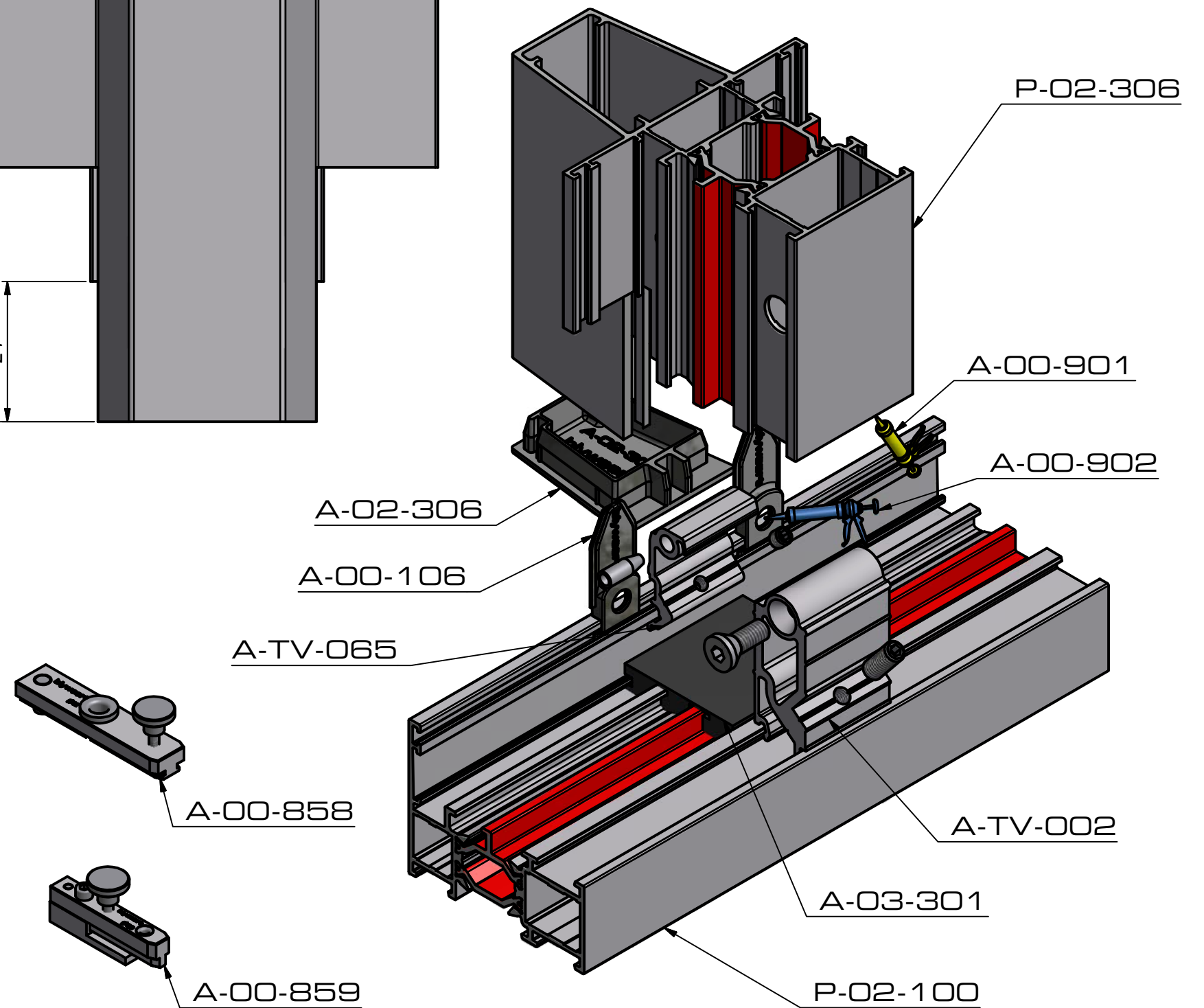
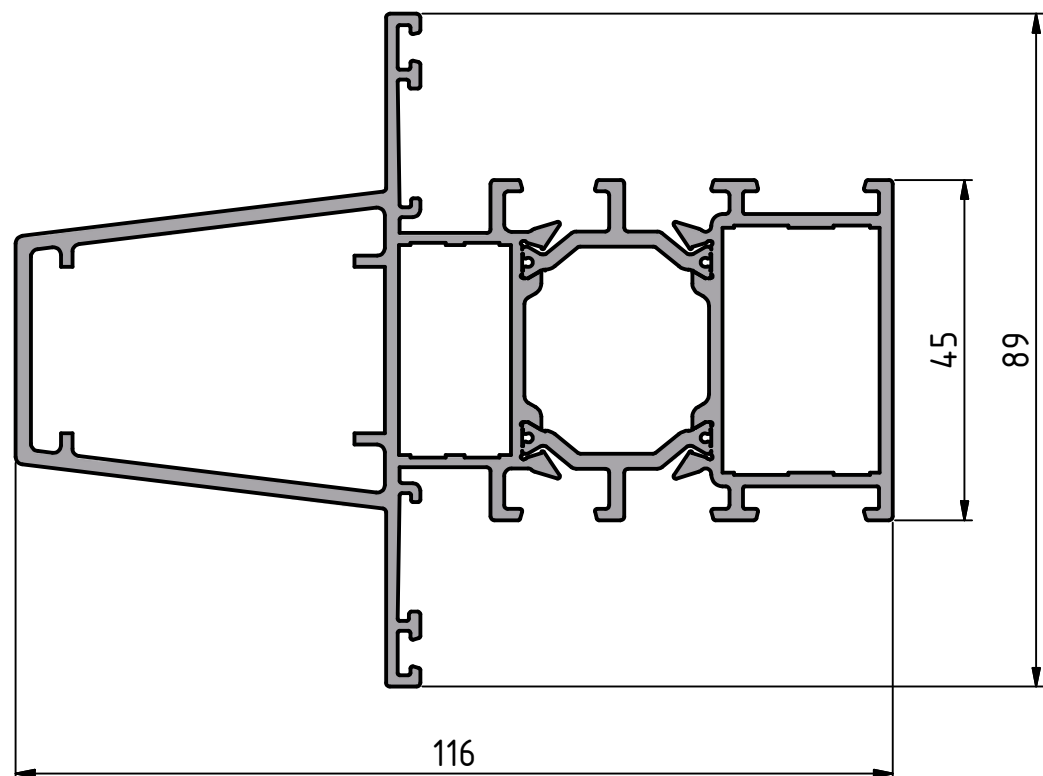
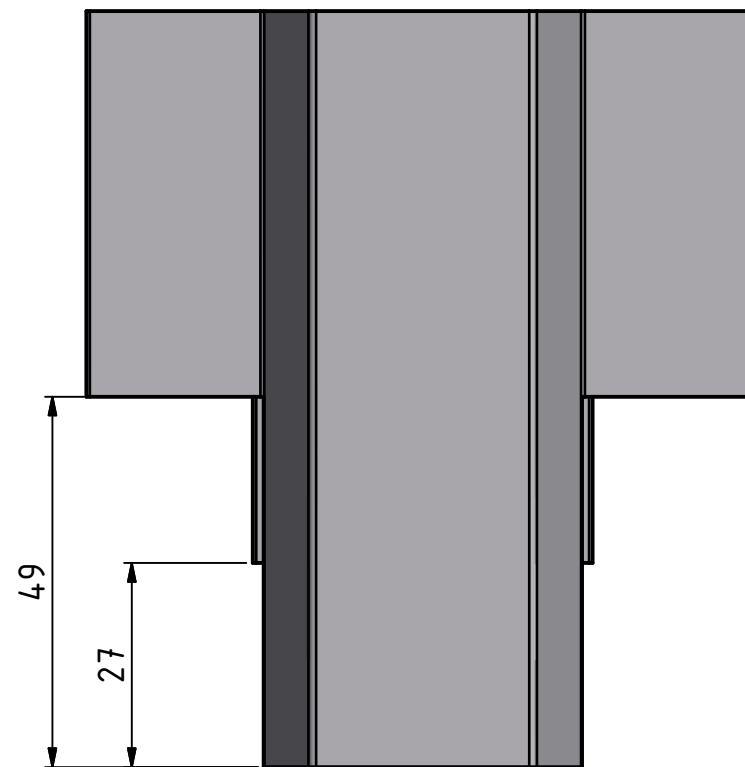
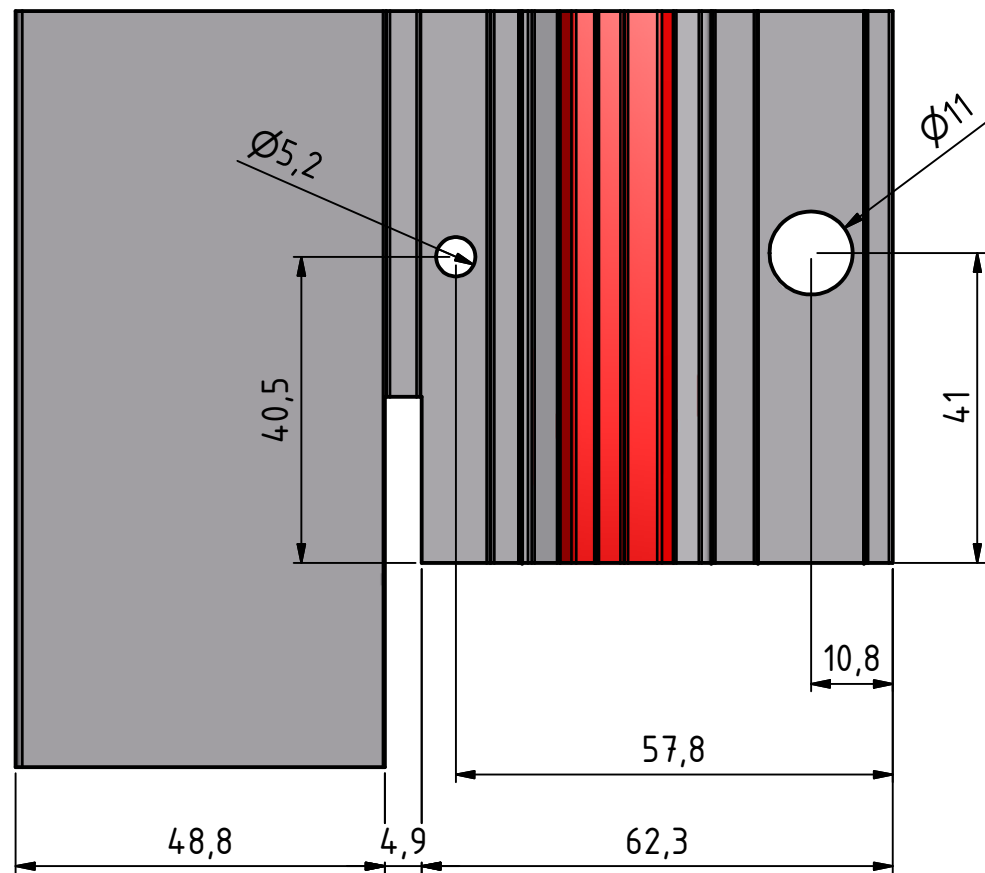

t-verbinding306.idw

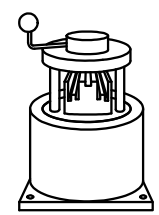
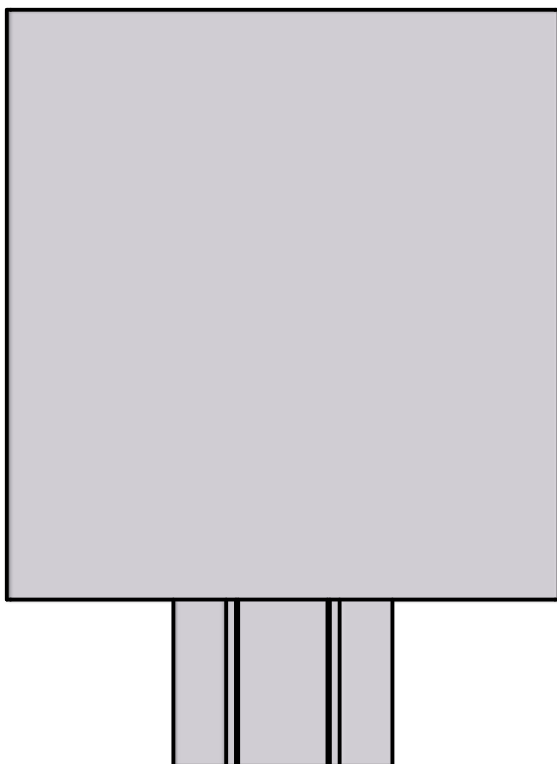
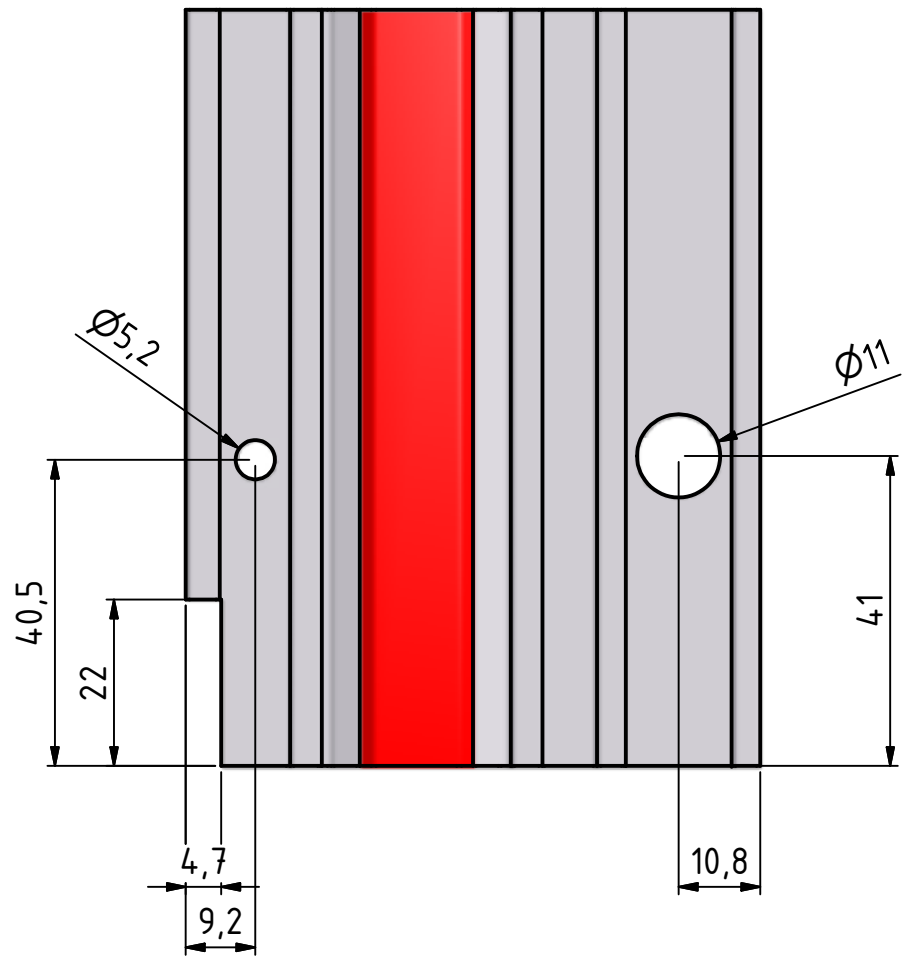

A-KM-5401

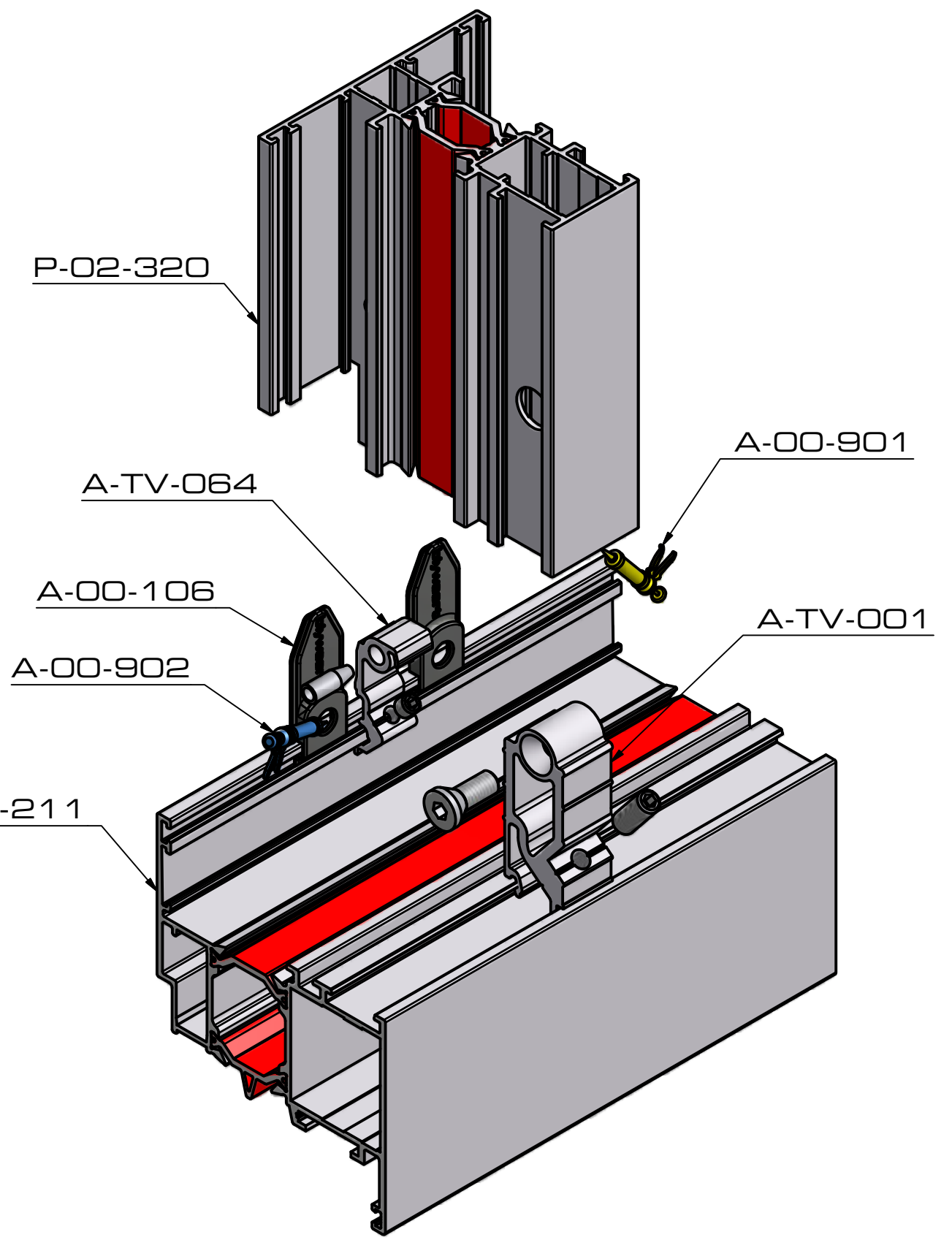
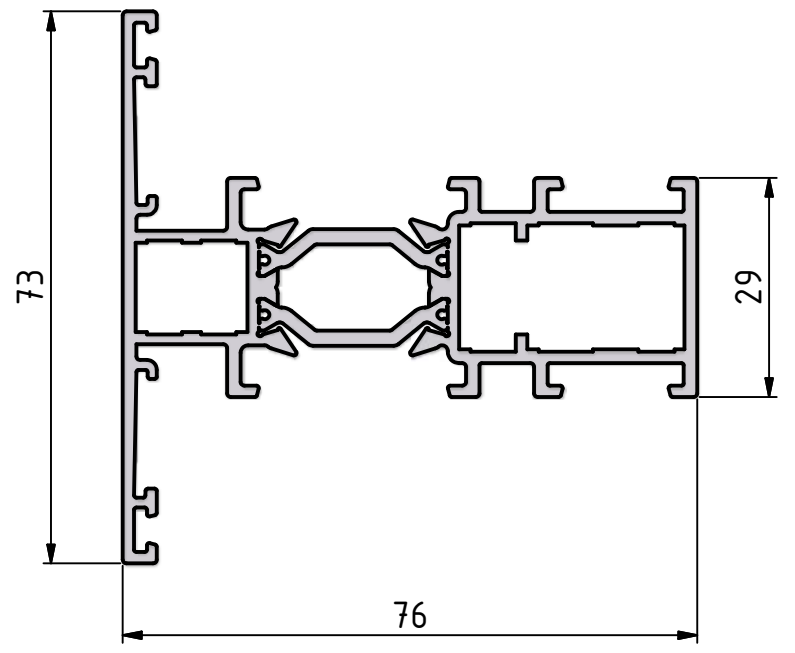

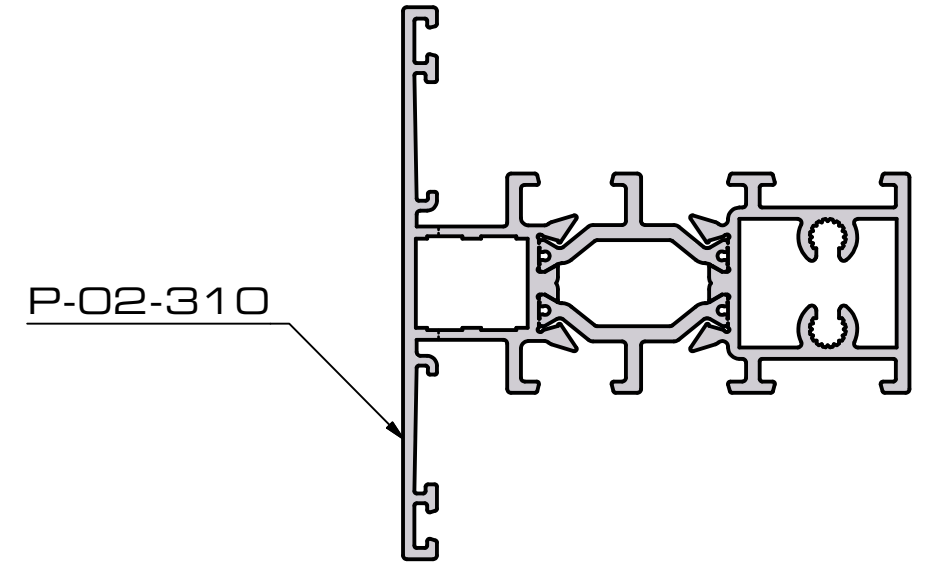
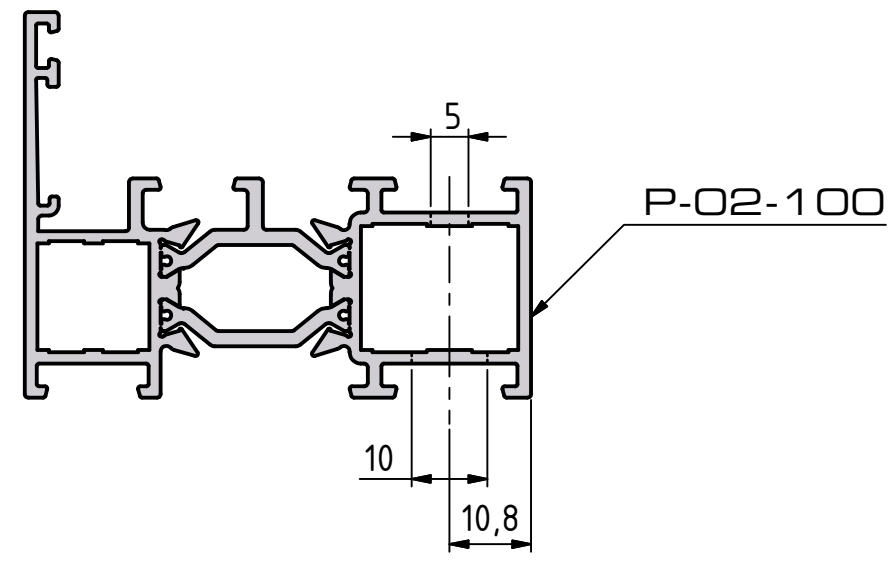
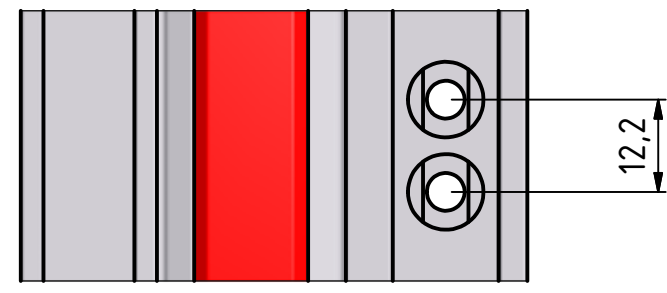
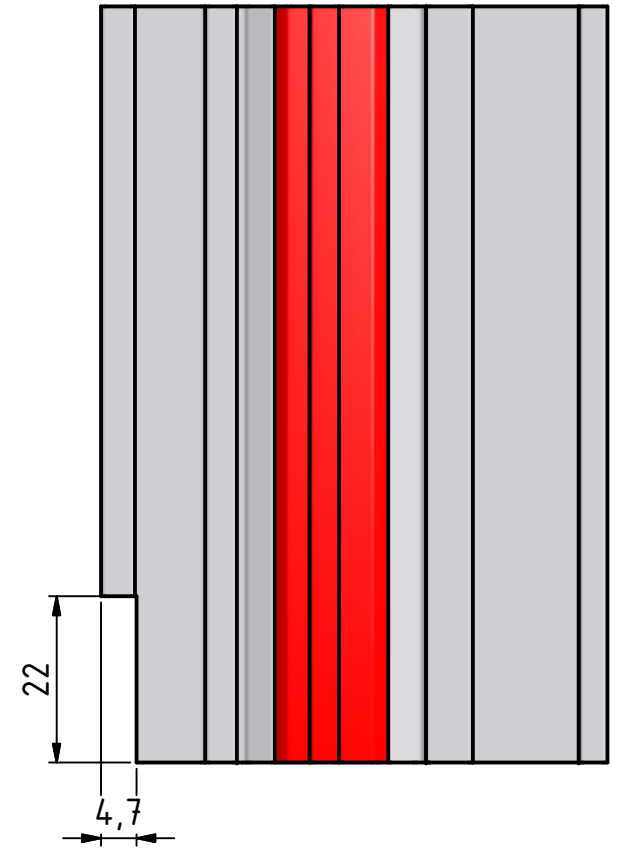
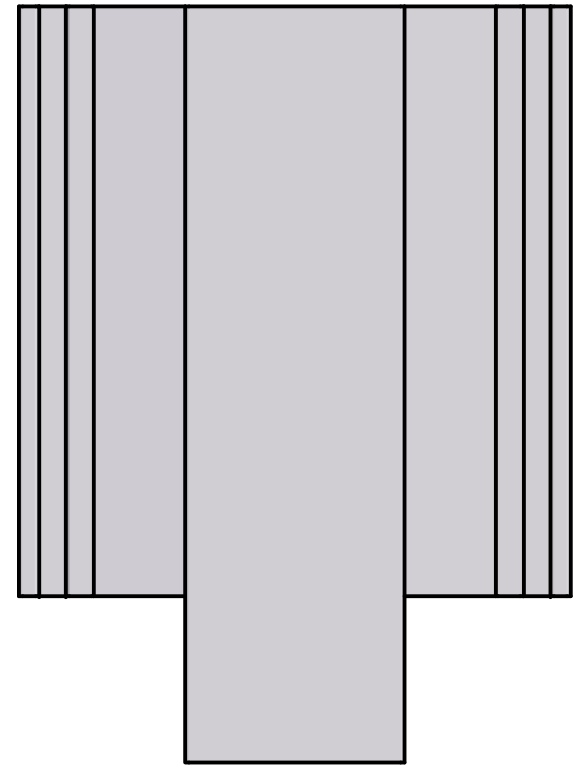
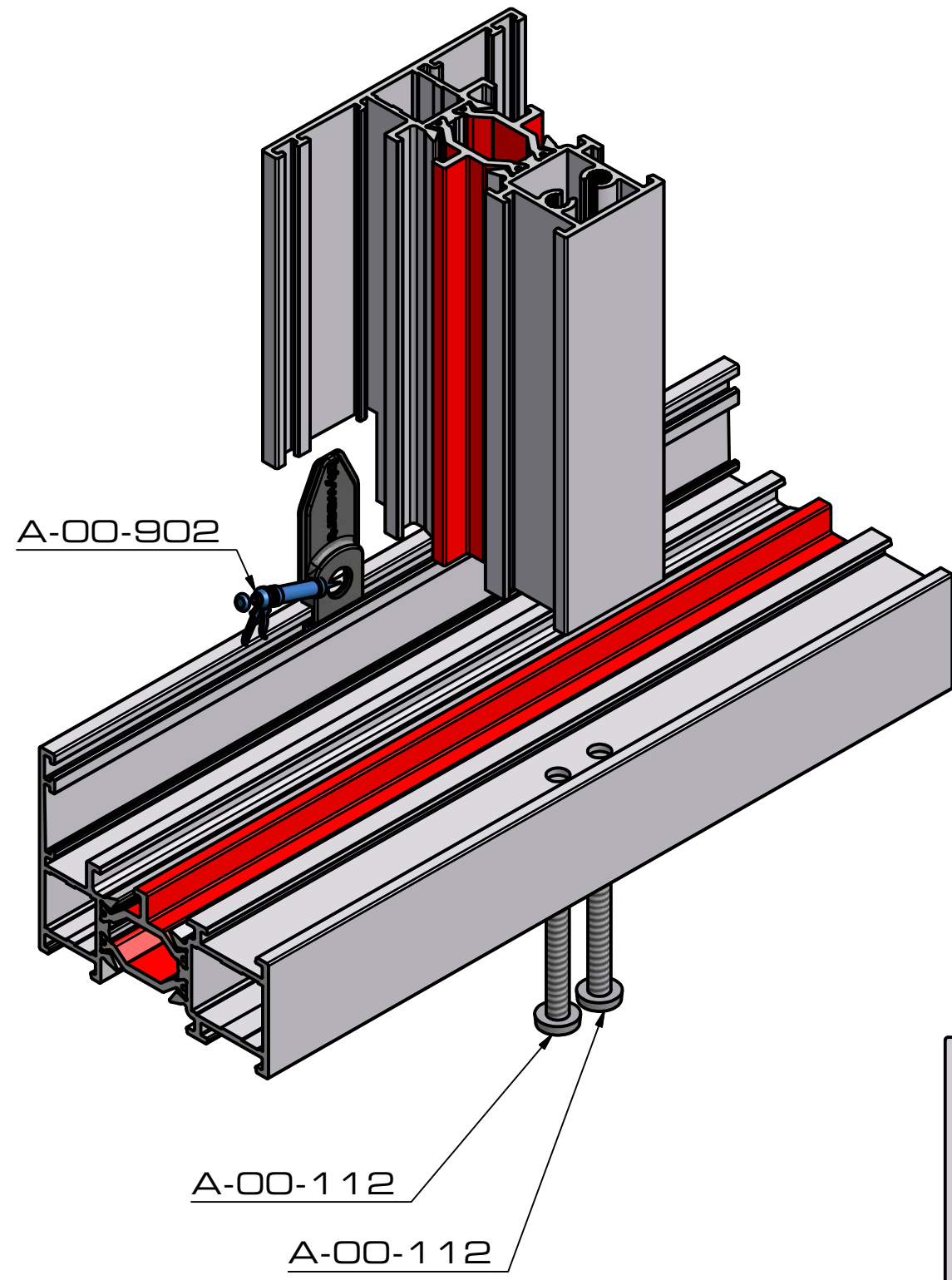

schroefverbinding.idw

P-02-100		A-VH-1415		A-00-851	
		A-VH-1621		A-00-850	
P-02-101		A-VH-3015		A-00-851	
		A-VH-3221		A-00-850	
P-02-102		A-VH-4015		A-00-851	
		A-VH-4221		A-00-850	
P-02-109		A-VH-1664		A-00-850	
		A-VH-3221		A-00-850	
P-02-111		A-VH-1415		A-00-851	
		A-VH-1621		A-00-850	
P-02-200		A-VH-1110		A-00-853	
		A-VH-1630		A-00-852	
P-02-210		A-VH-1110		A-00-853	
		A-VH-1630		A-00-852	
P-02-300		A-VT-1115		A-00-855	
		A-VT-1621		A-00-854	
P-02-301		A-VT-2715L/R		A-00-855	
		A-VT-3221L/R		A-00-854	

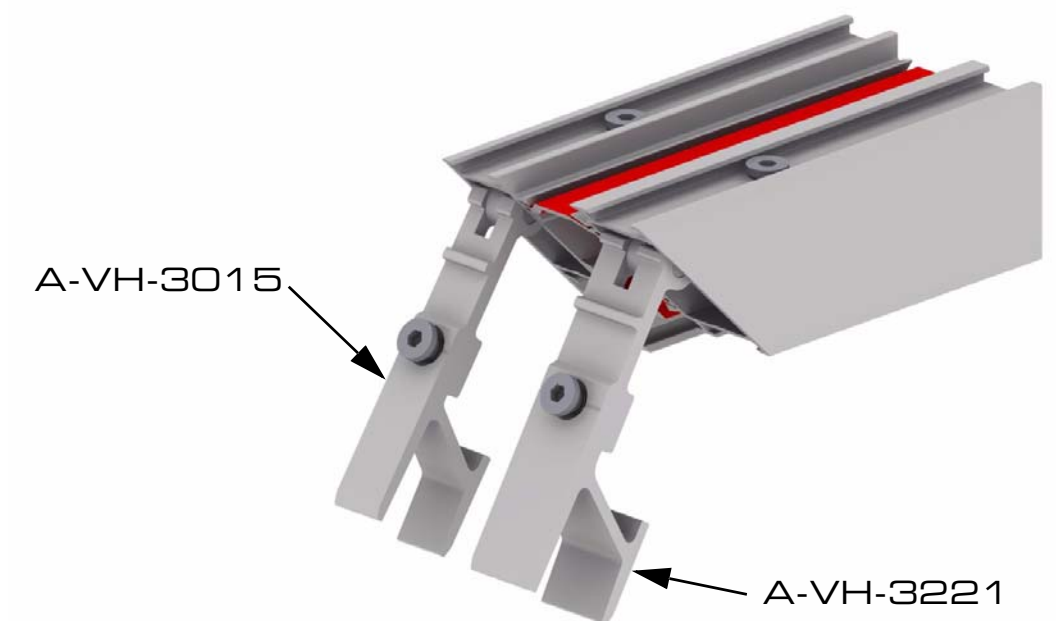
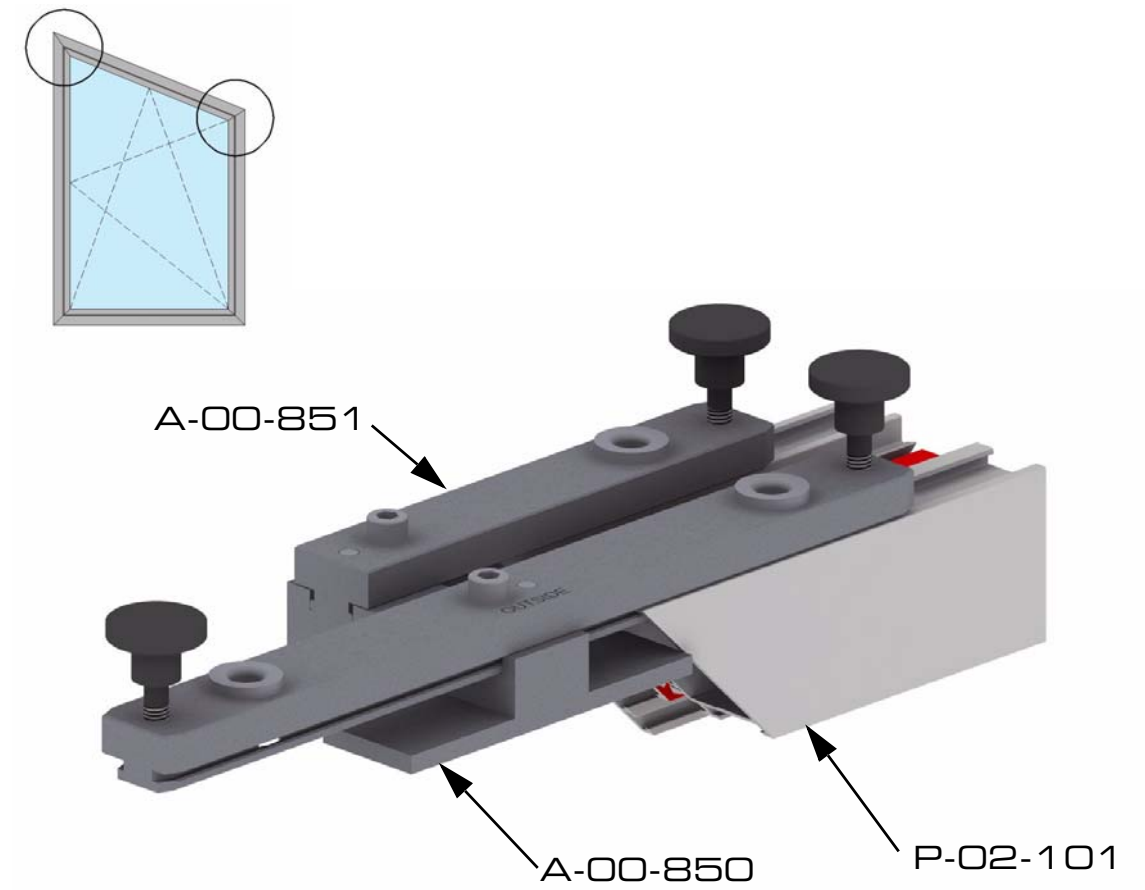

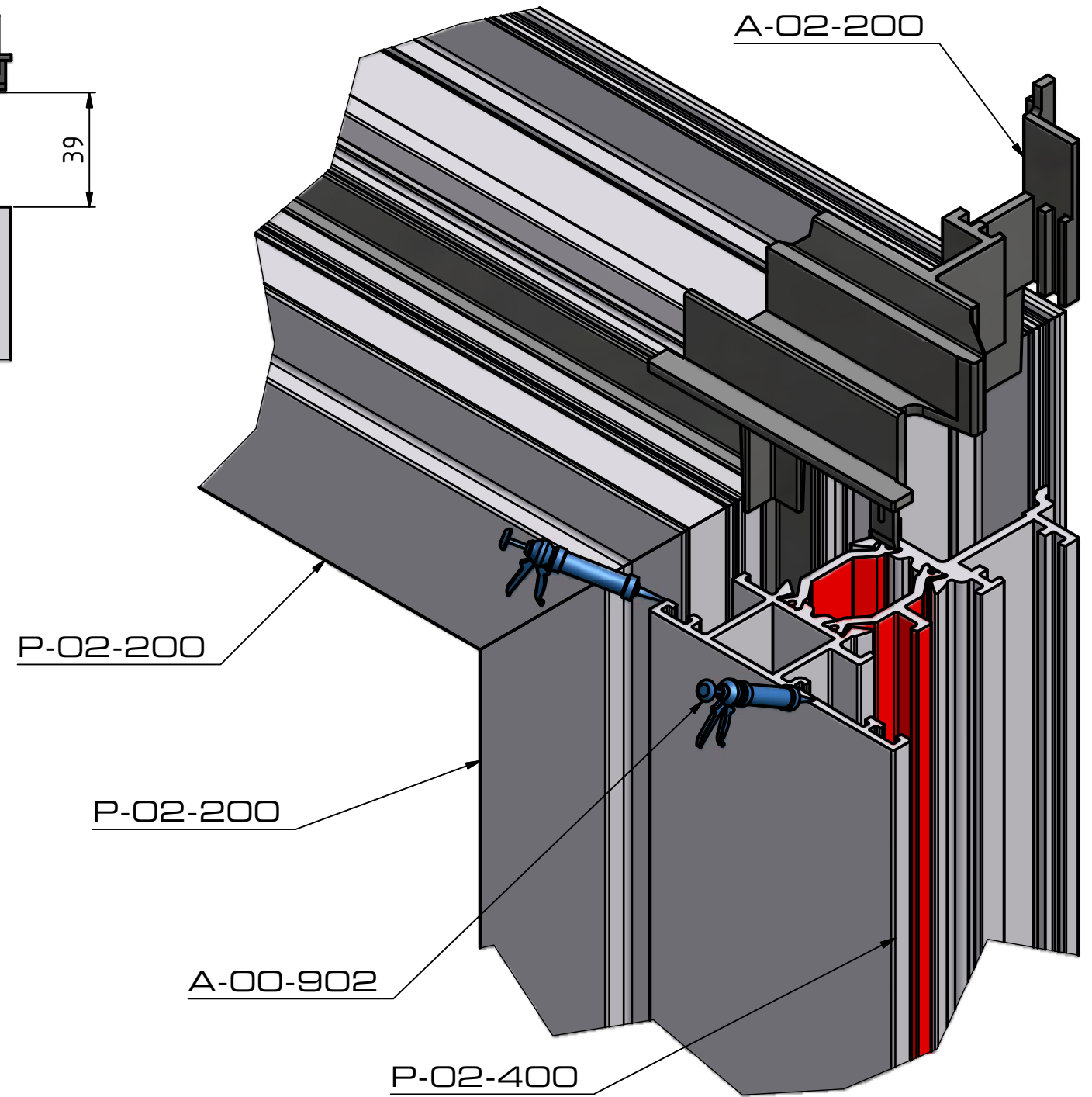
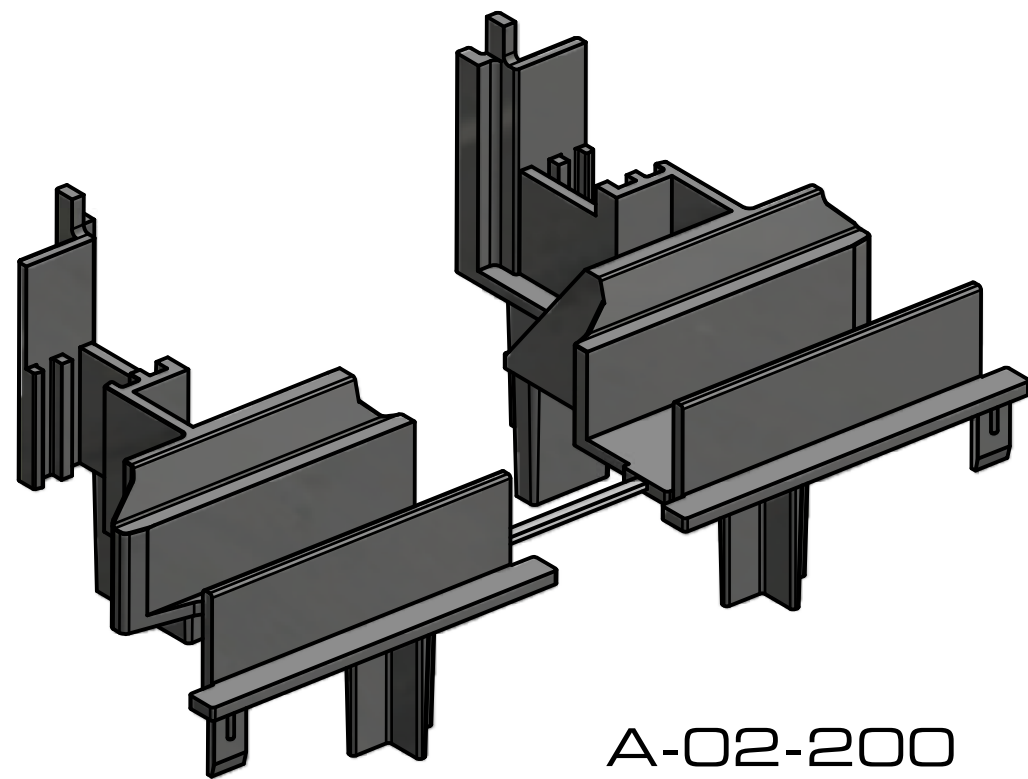
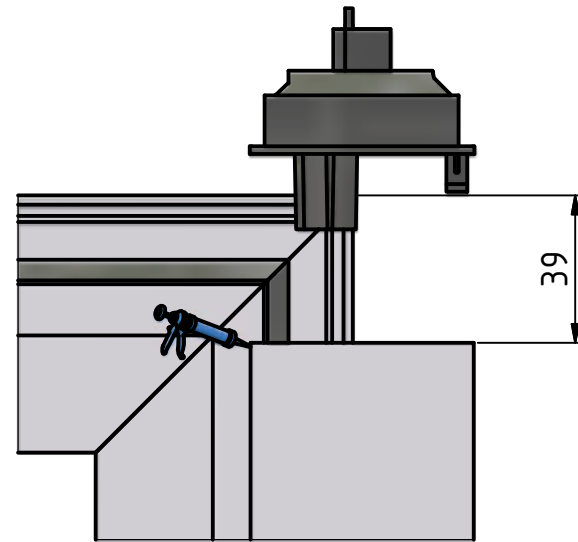
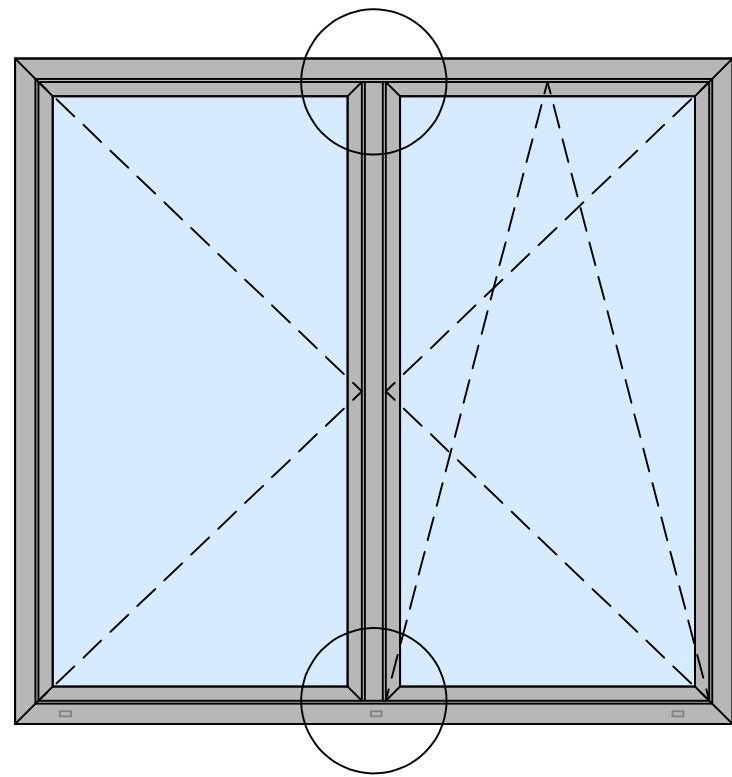

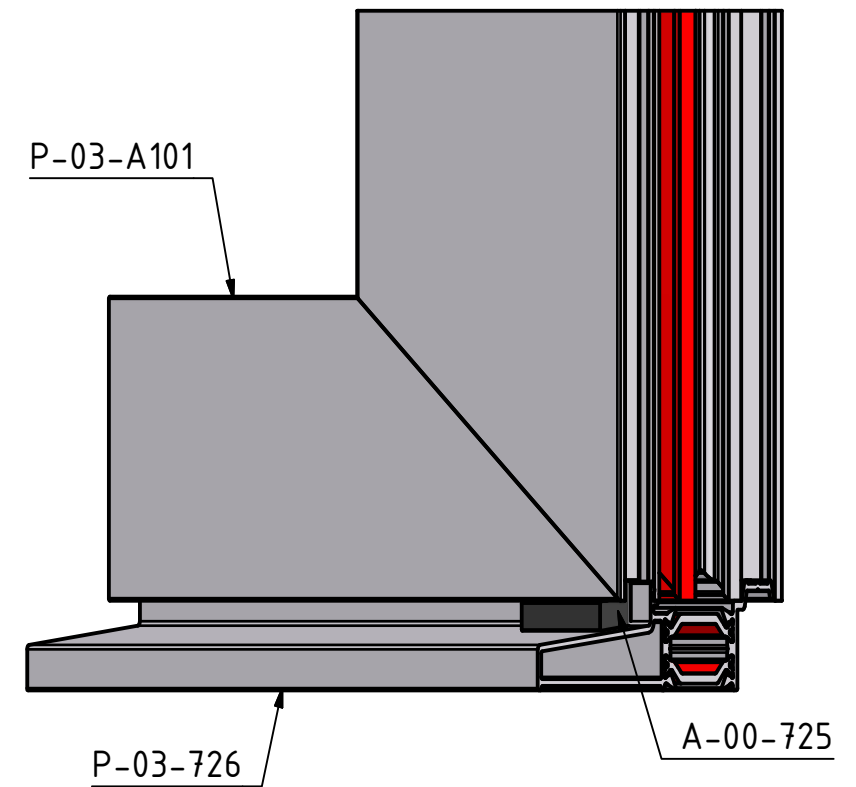
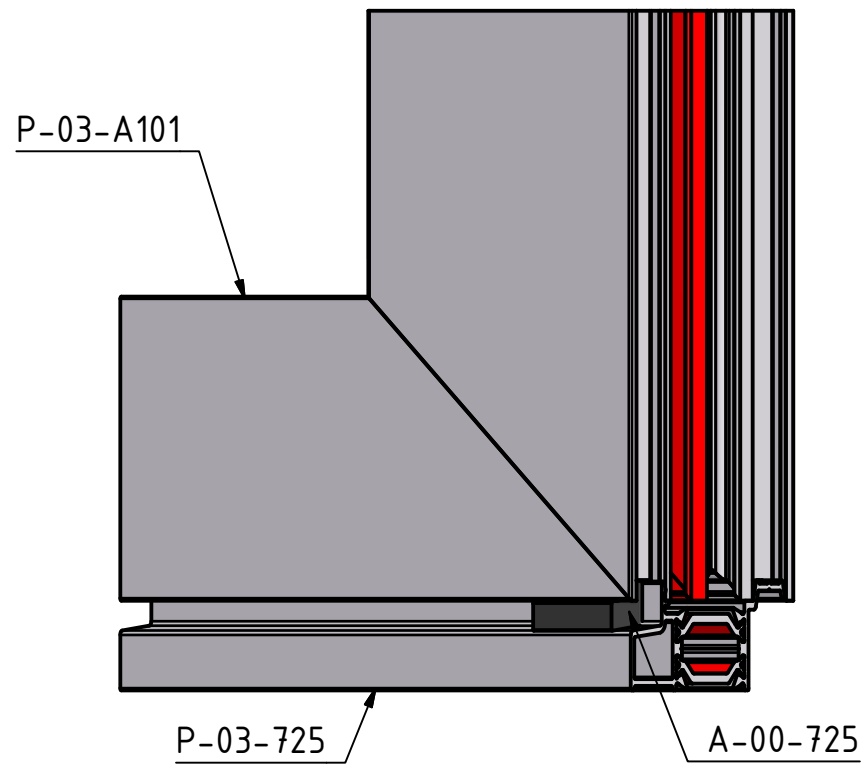
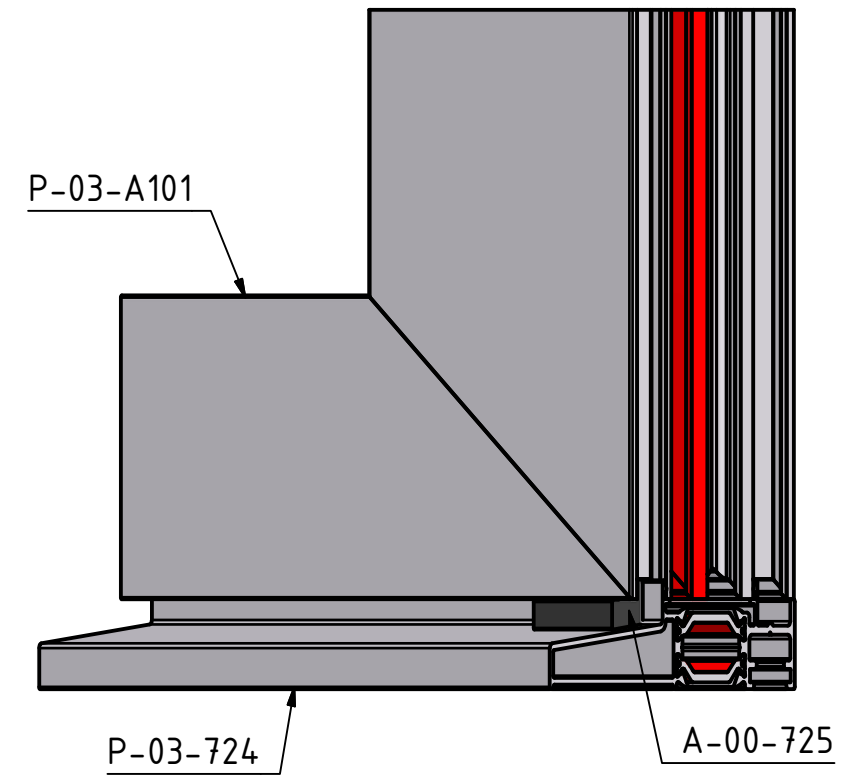
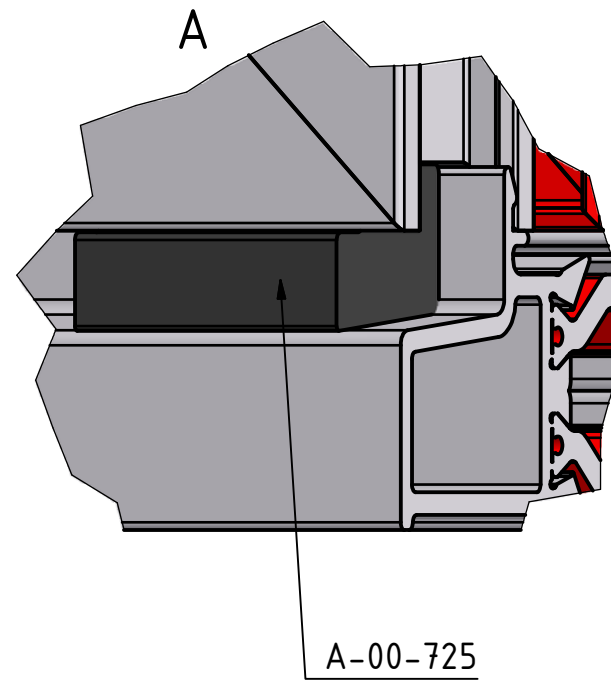
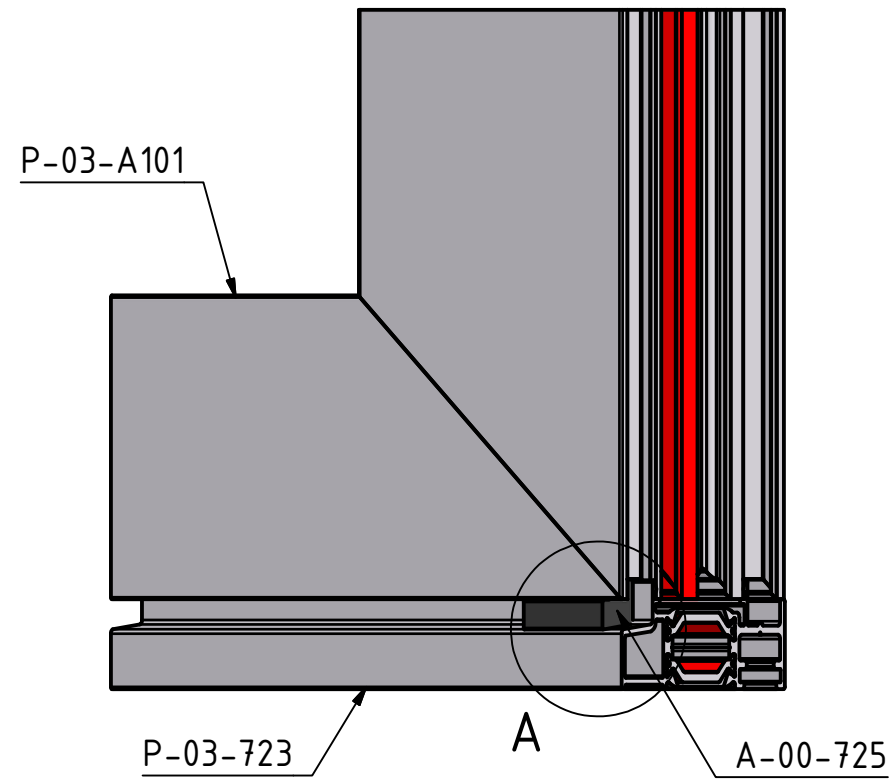

eindrubber.idw

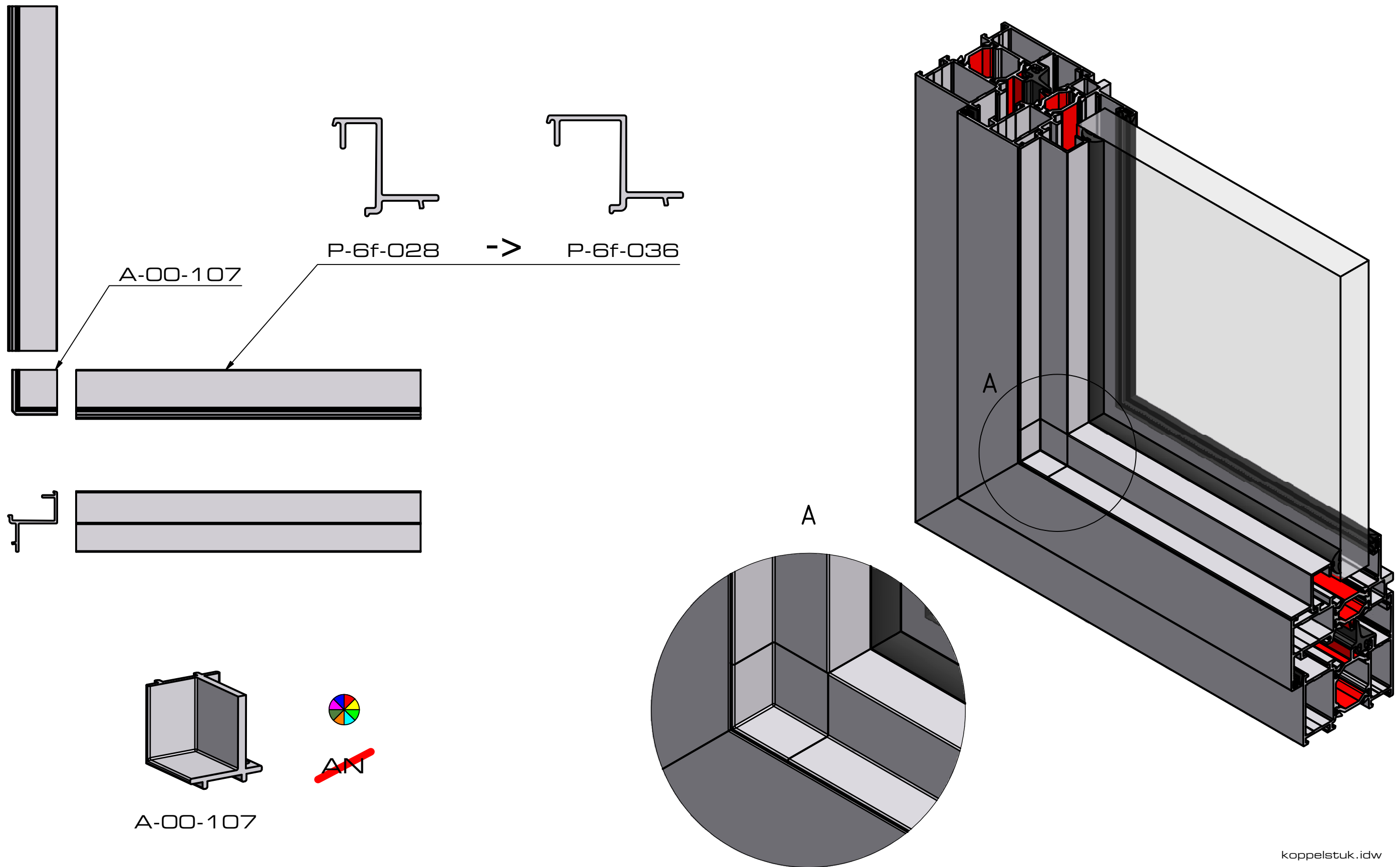

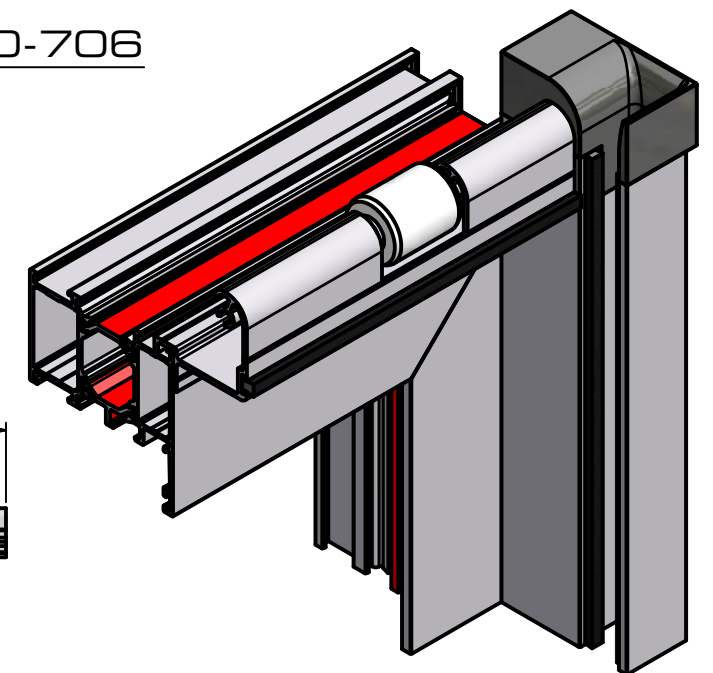
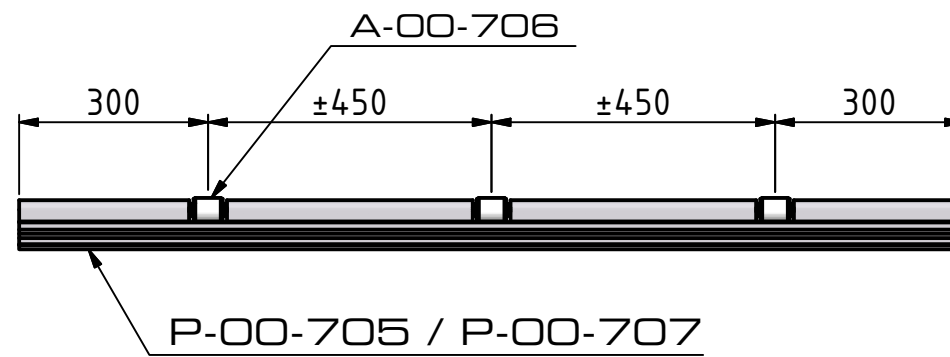
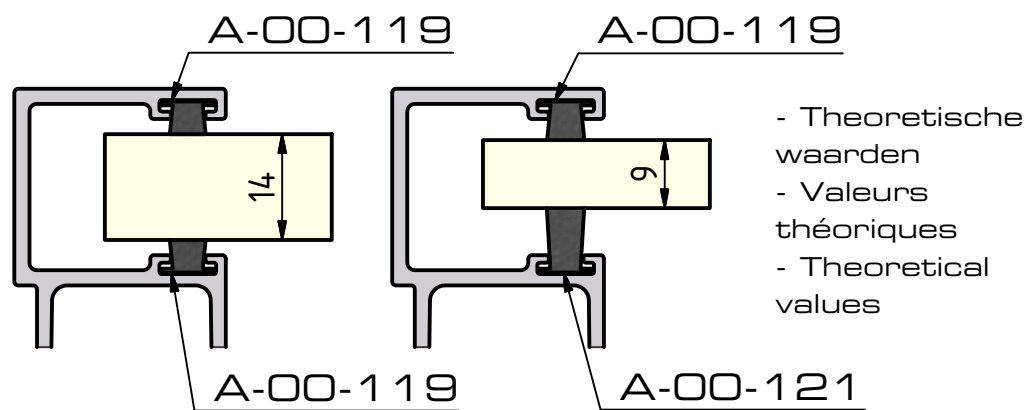
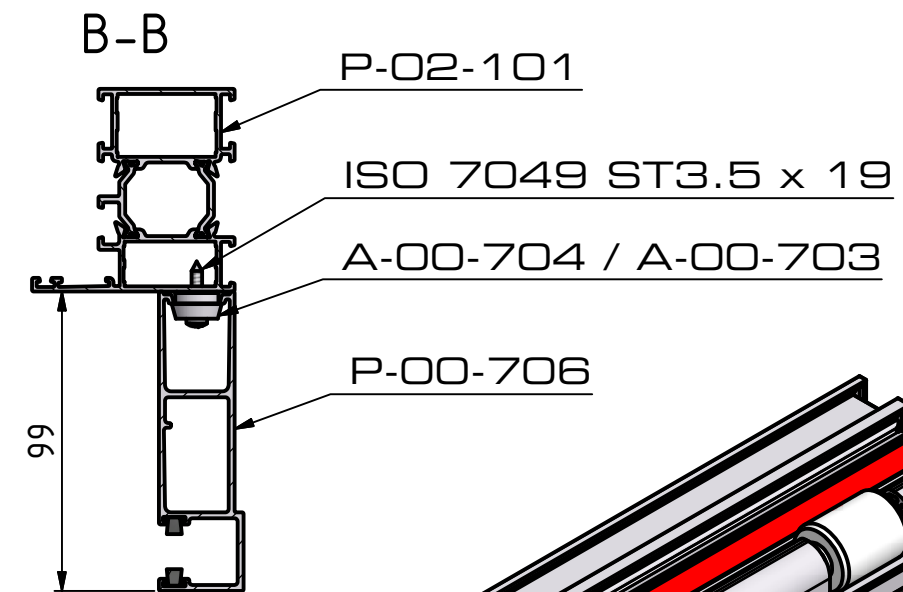
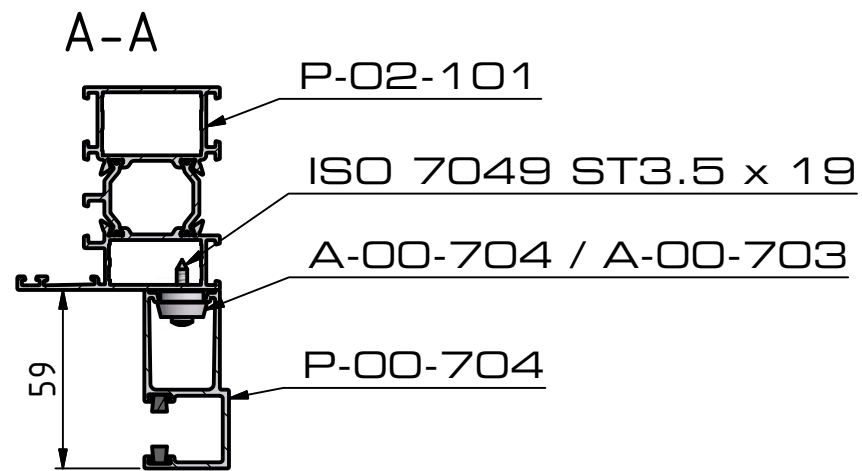
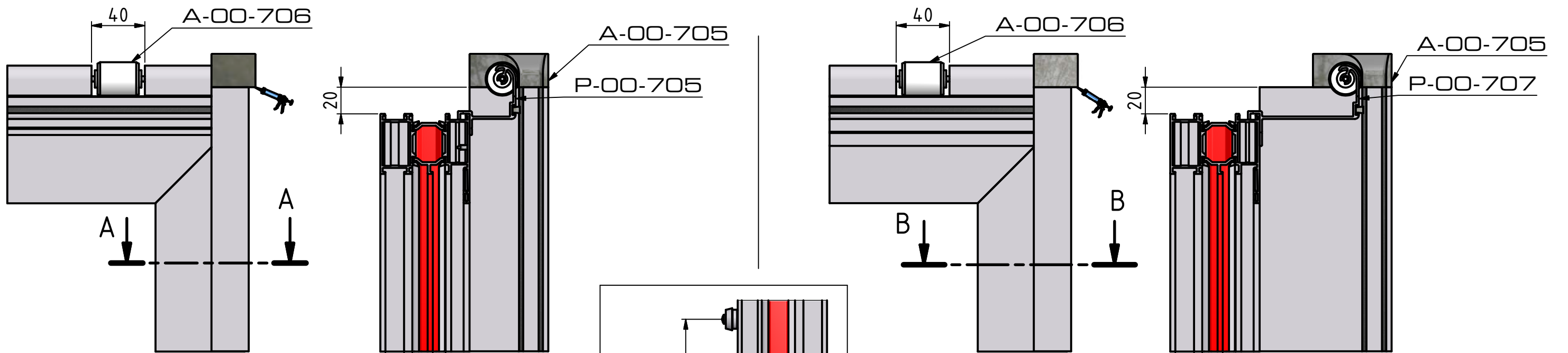

RolluikHC.idw

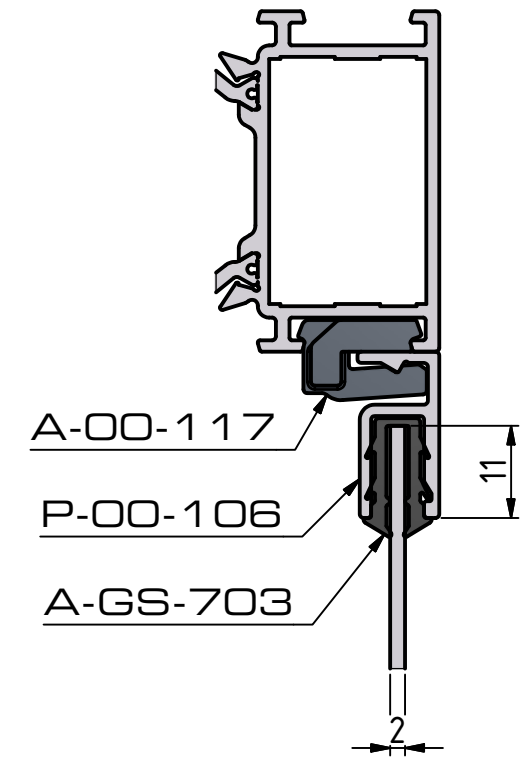
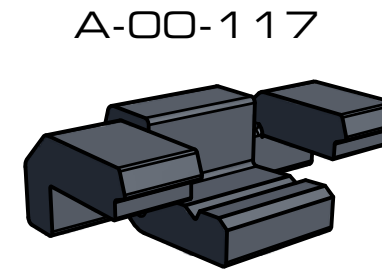
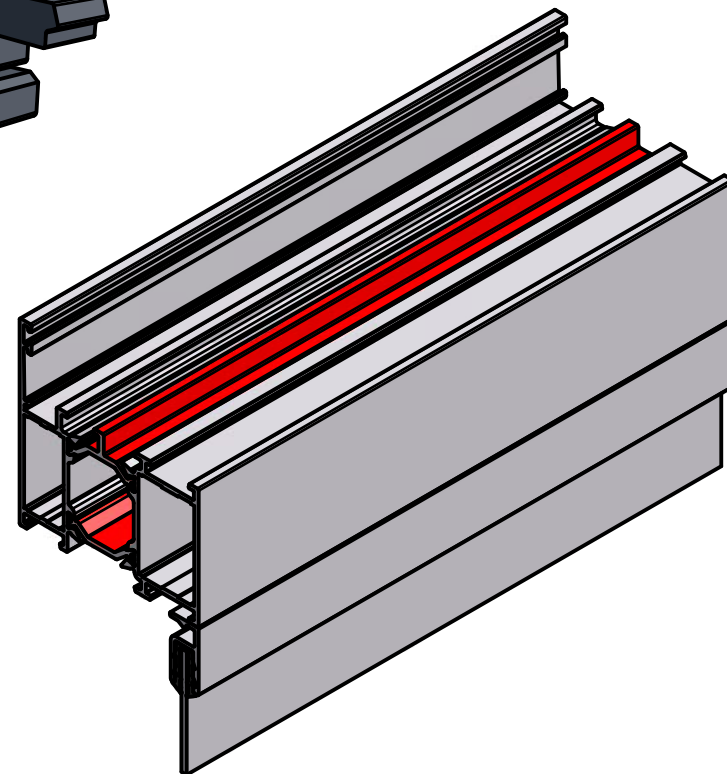
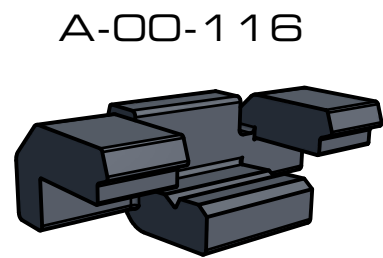
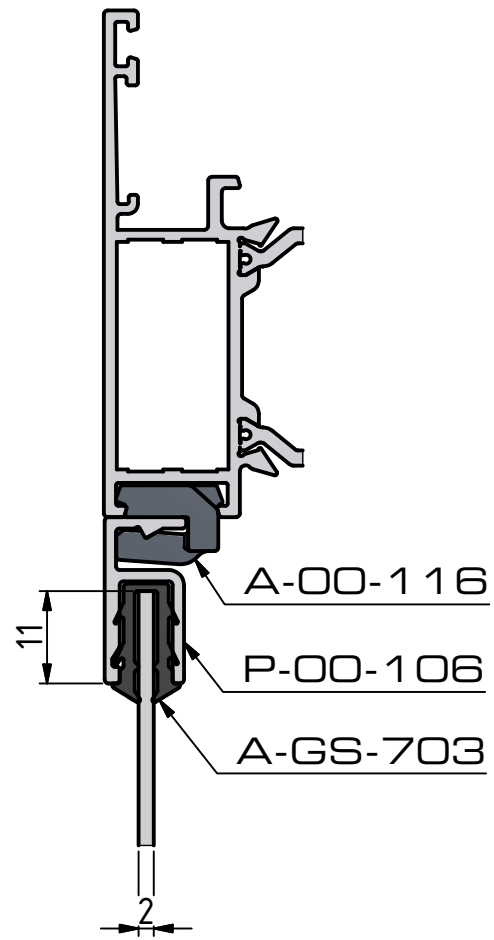
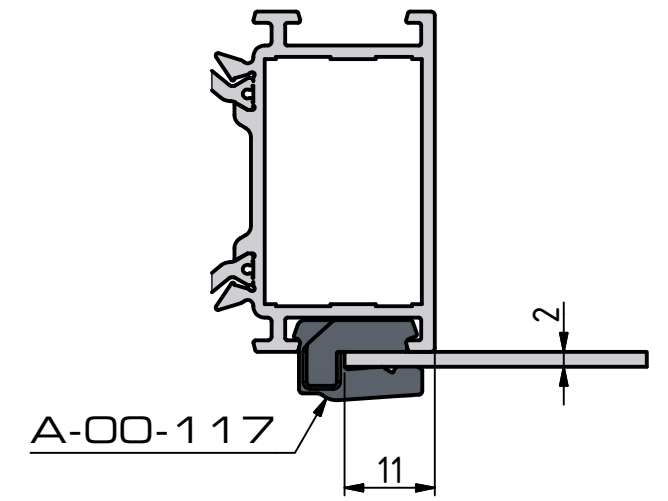
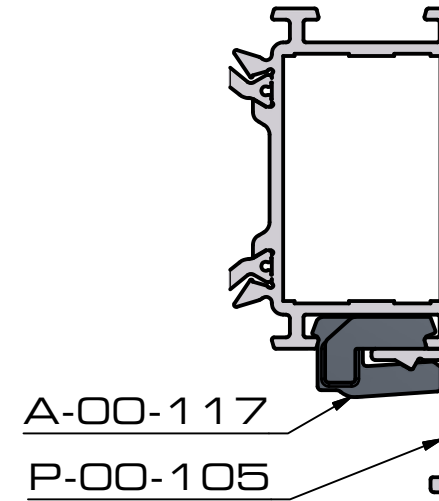
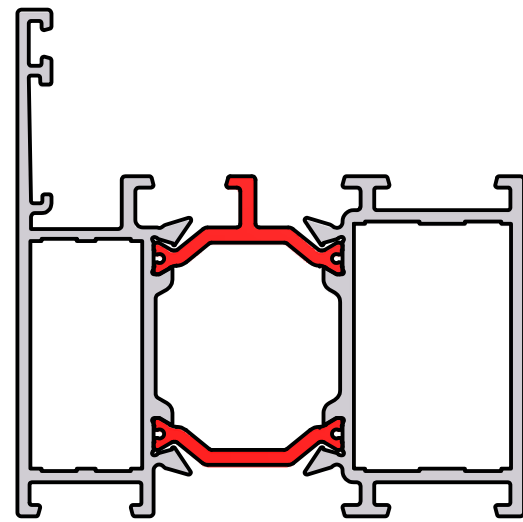
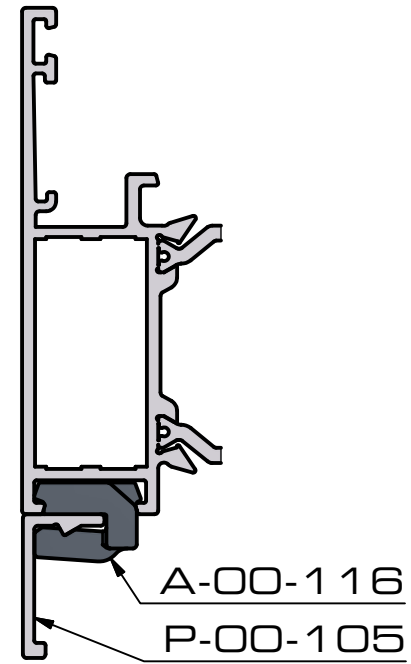
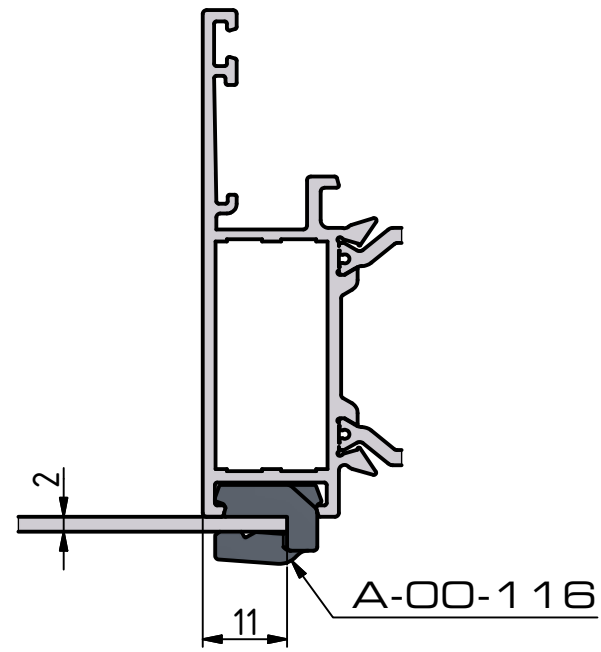

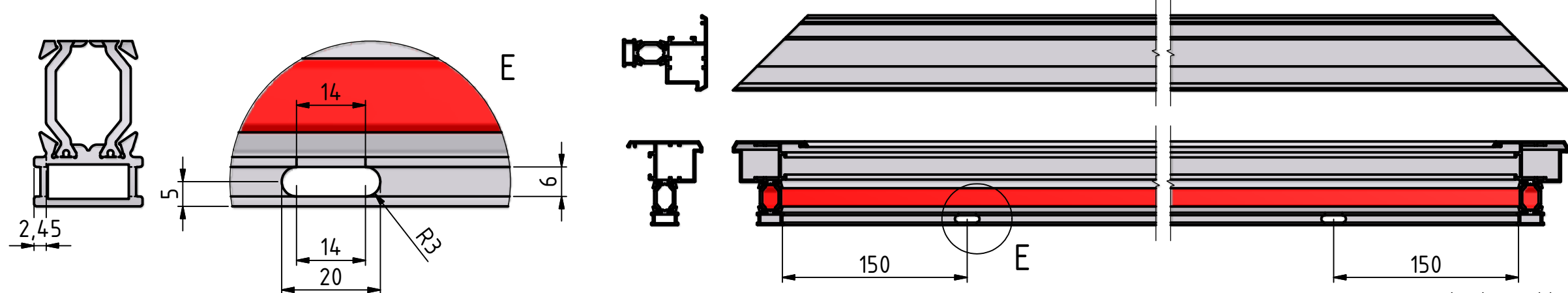
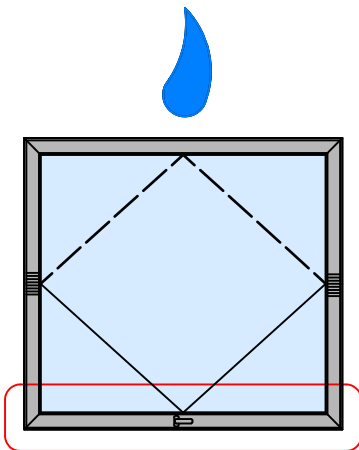
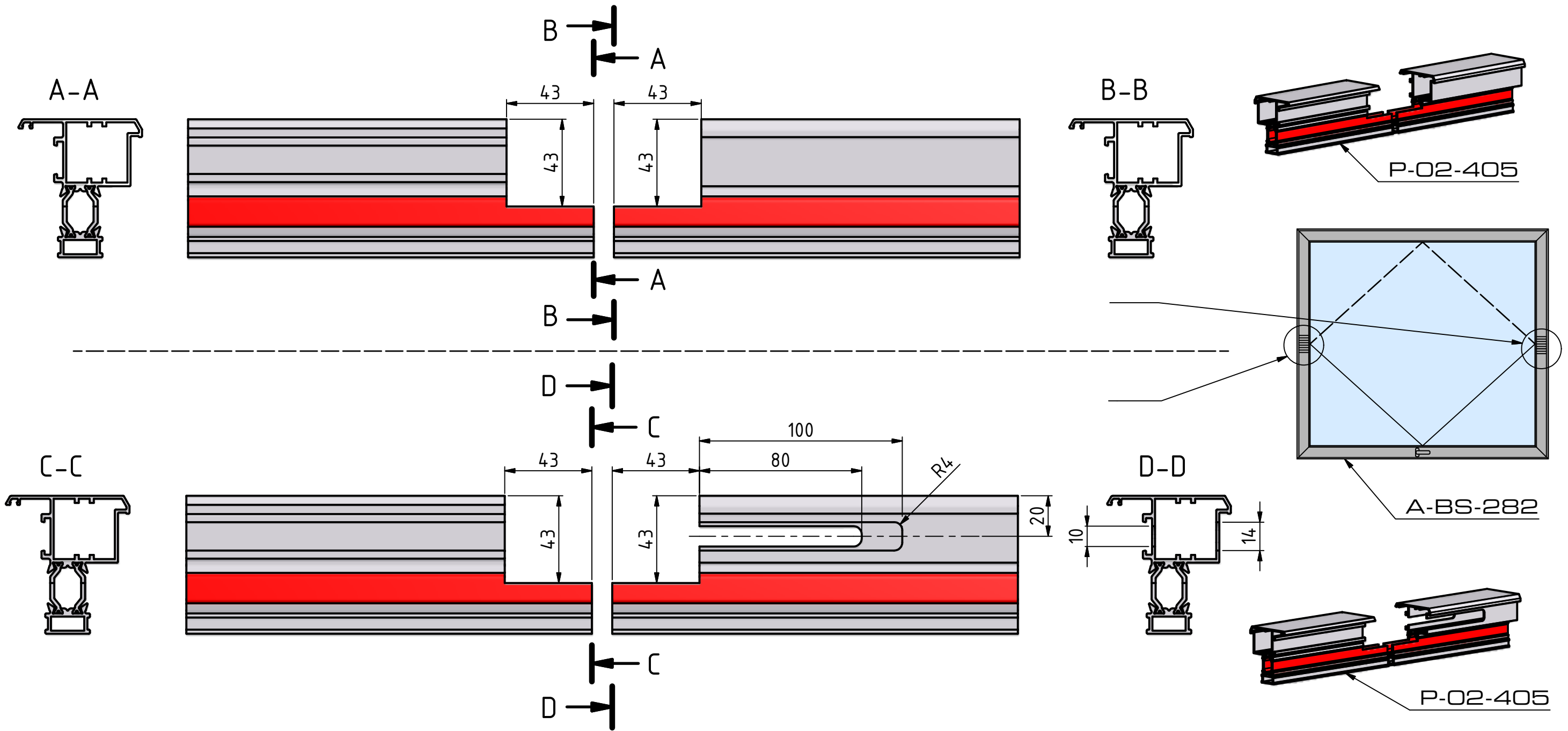

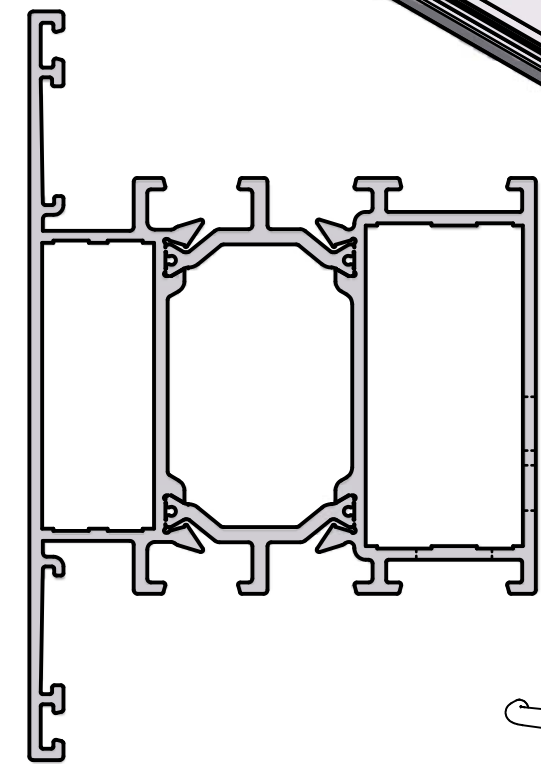
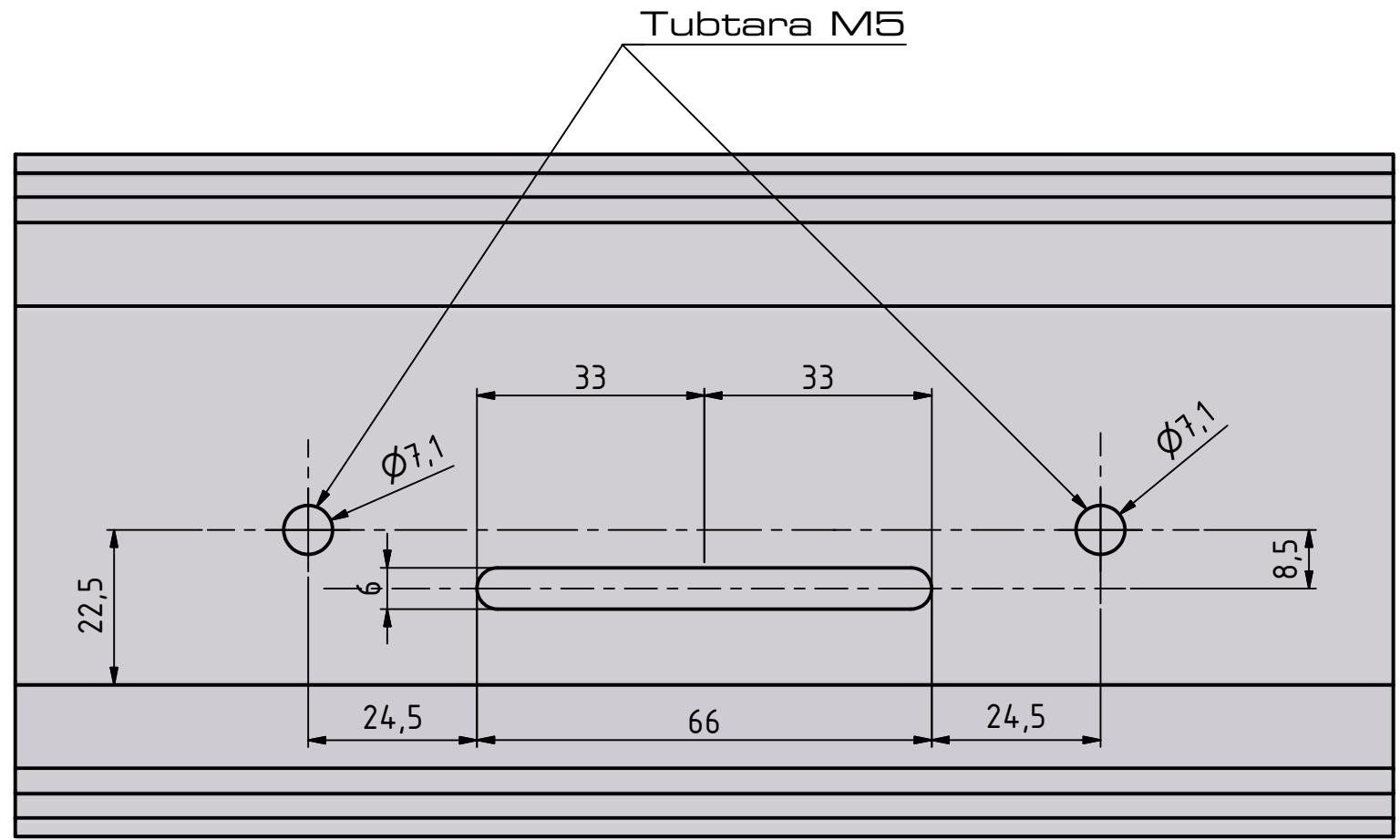
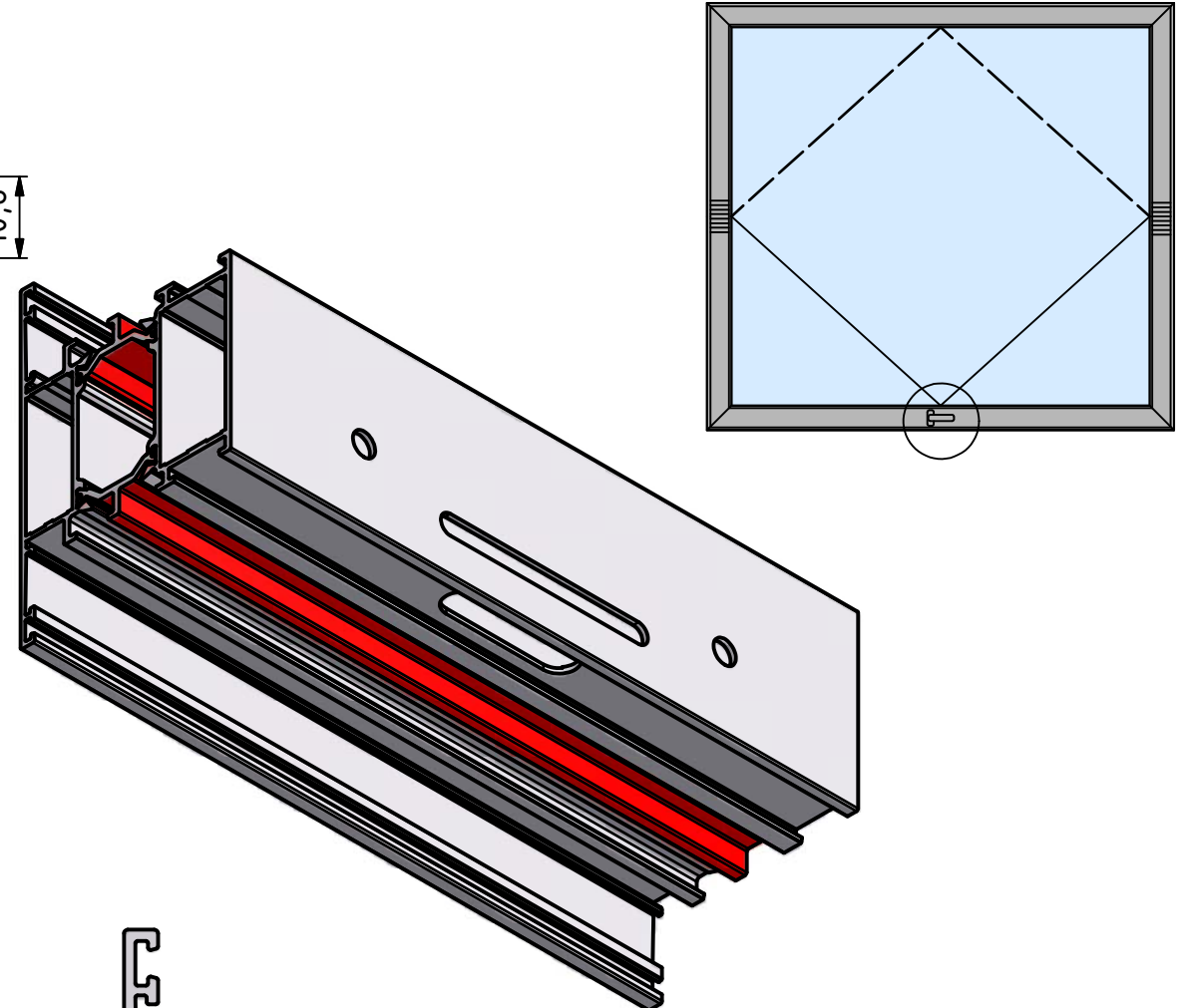
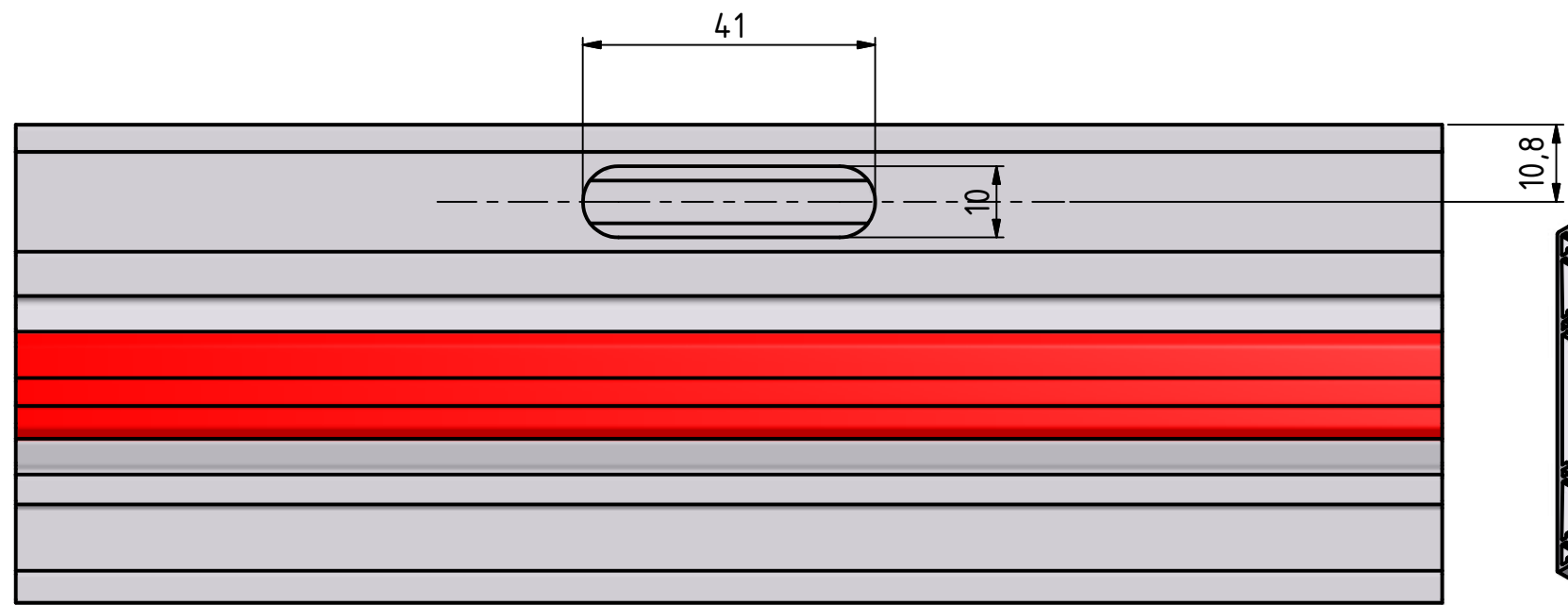

A-BS-280L
A-BS-280R

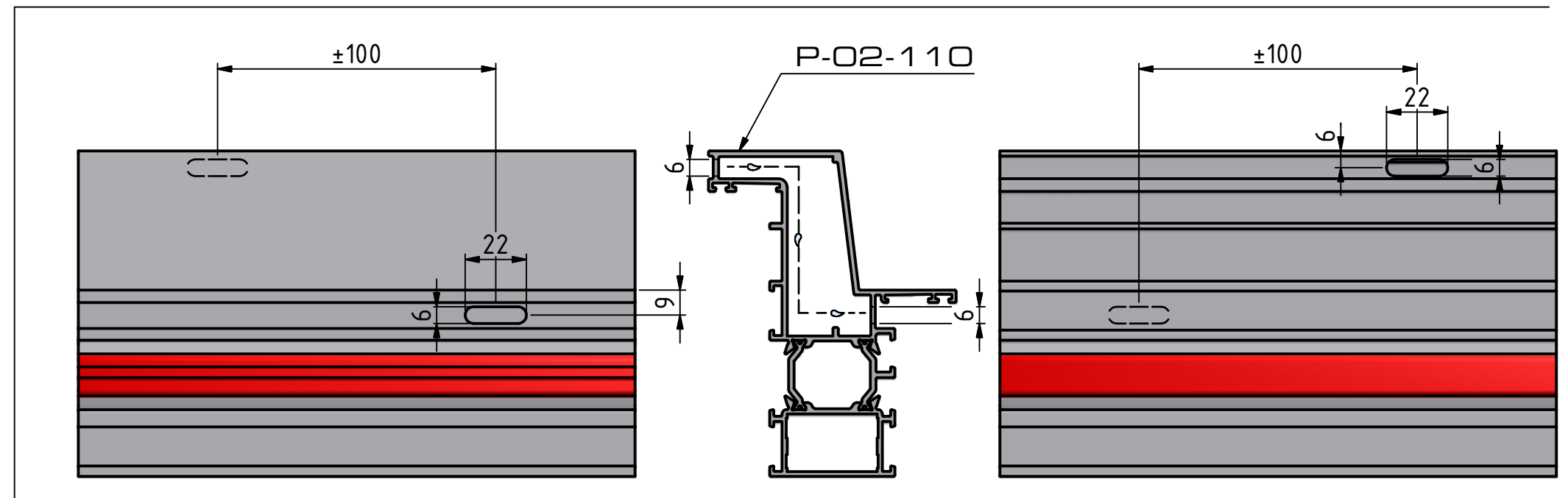
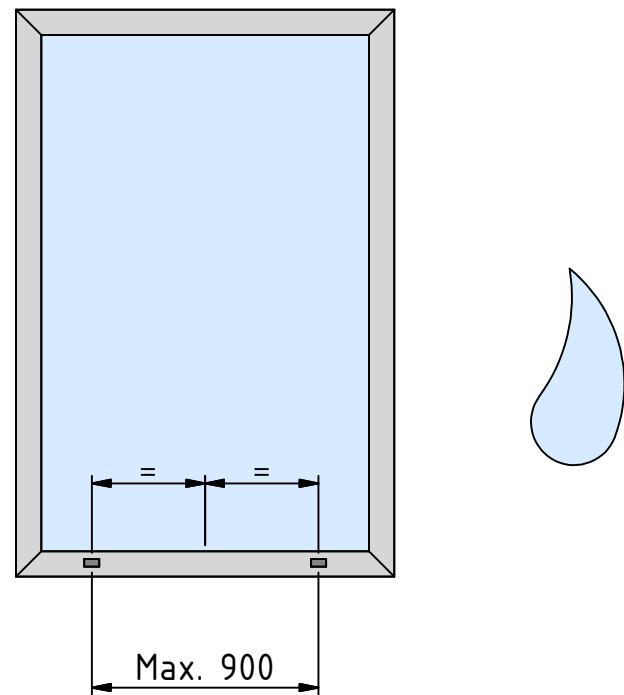
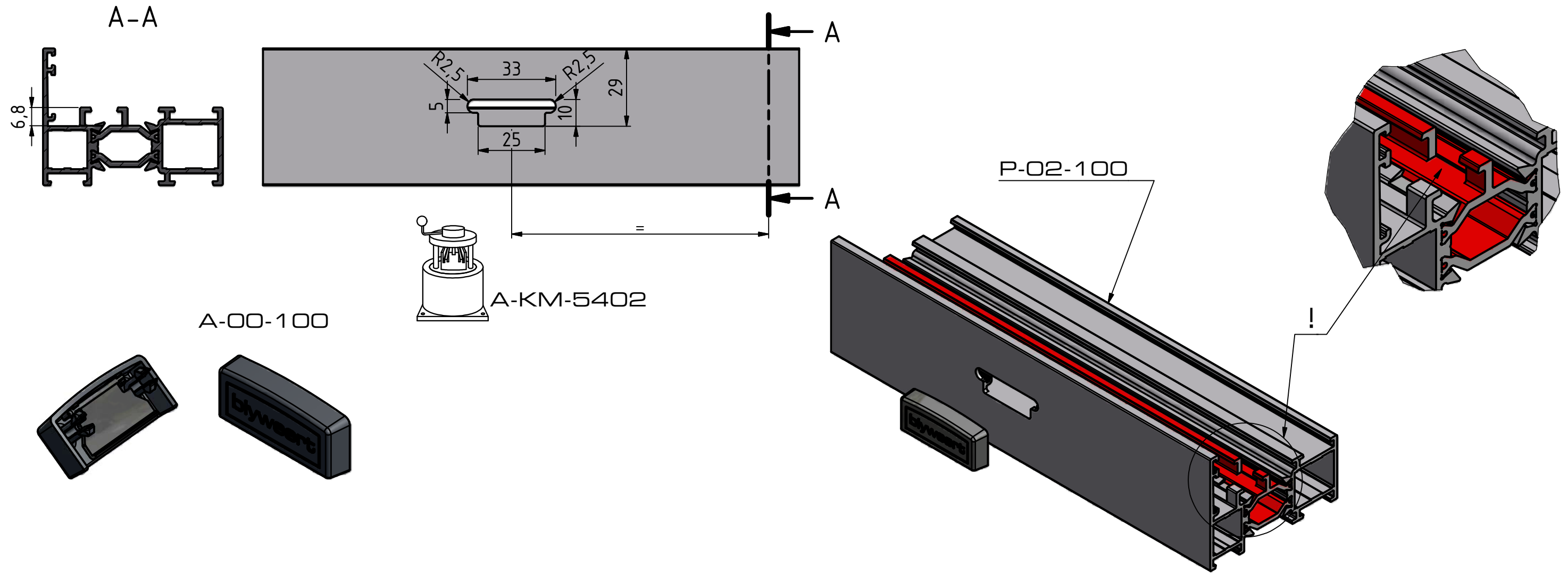

waterkapje.idw

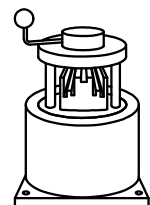
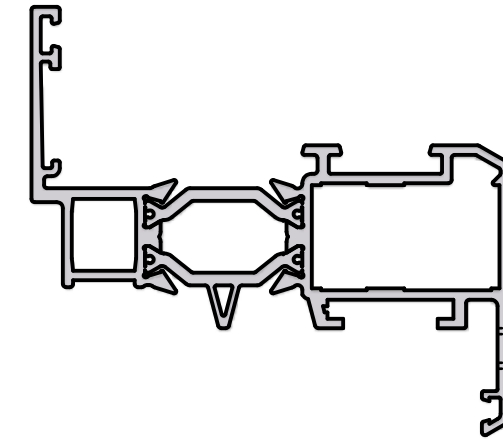
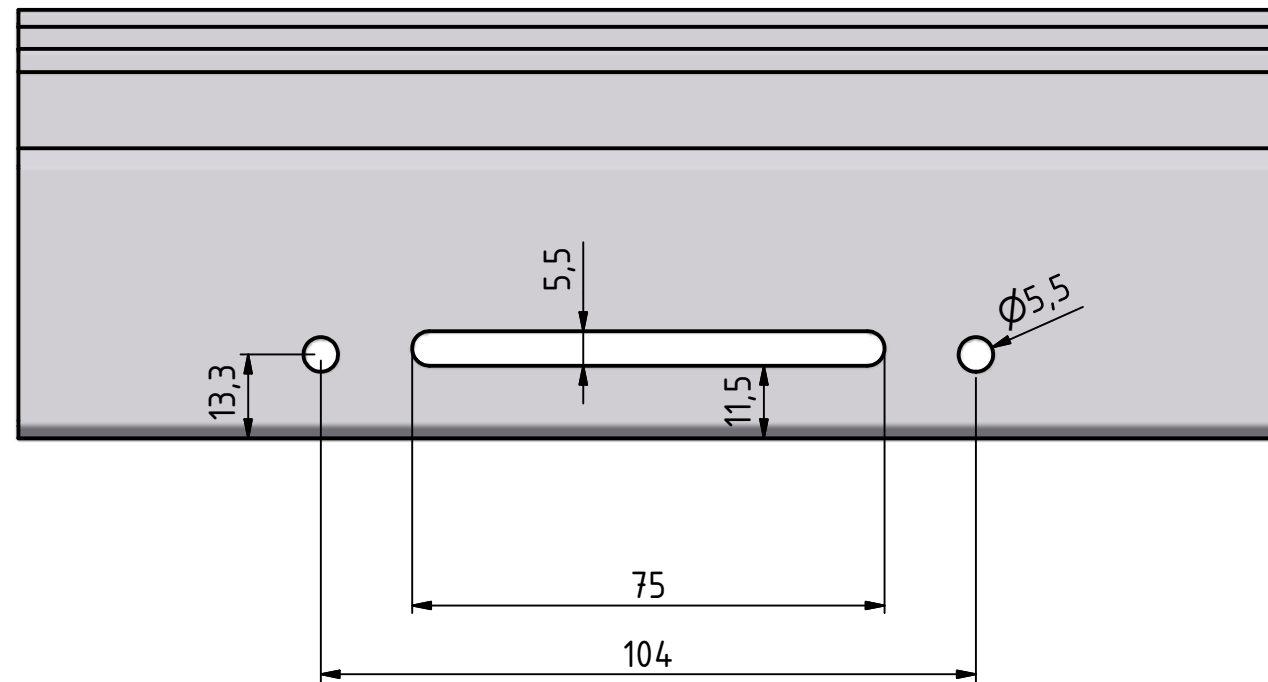

A-KM-5402

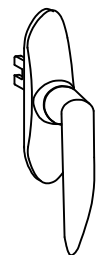

- | | |
|----------|----------|
| A-BS-023 | A-BF-004 |
| A-BS-024 | A-BF-005 |
| A-BS-084 | A-BF-006 |

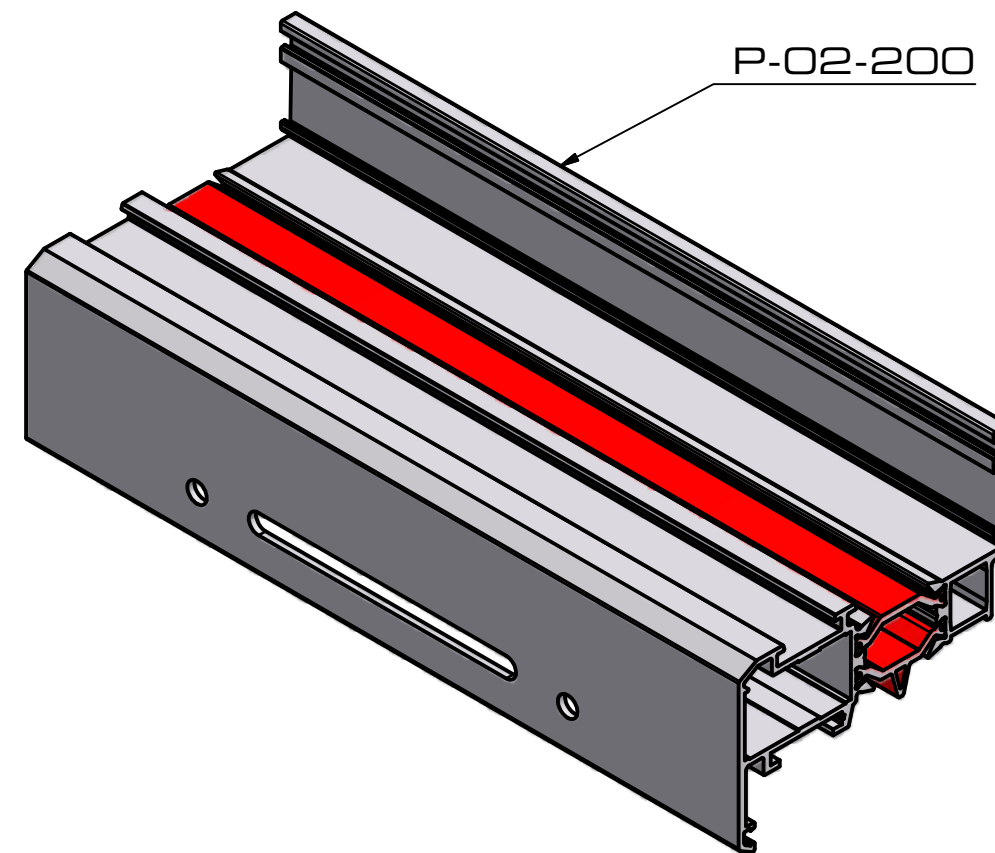

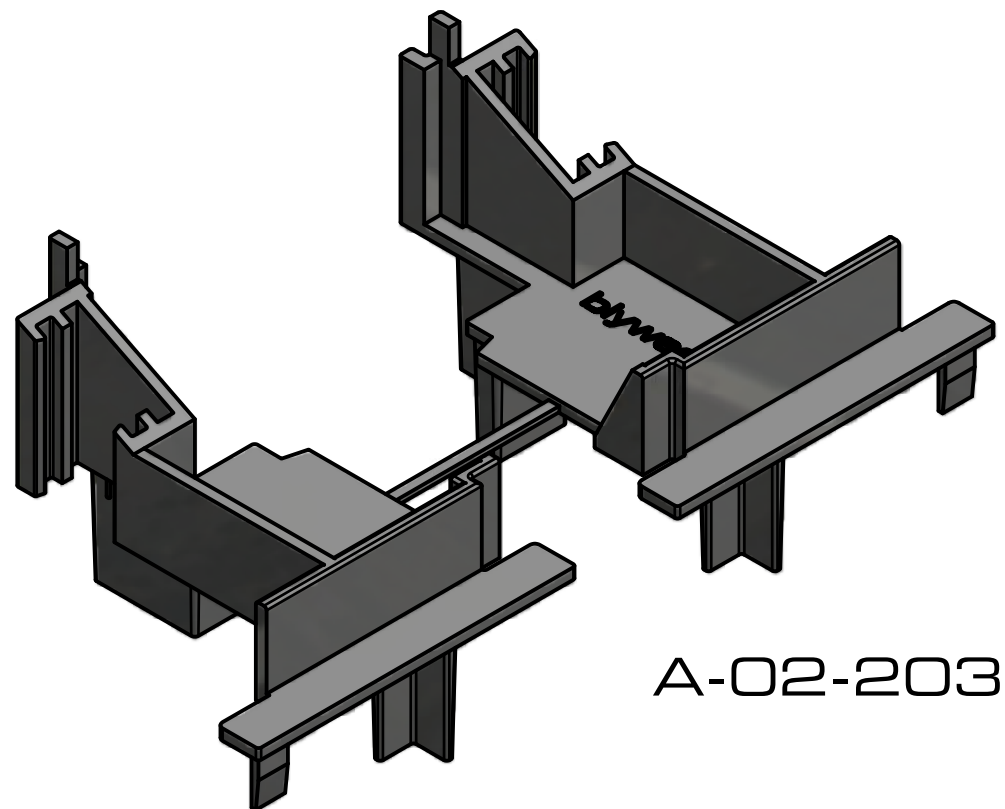
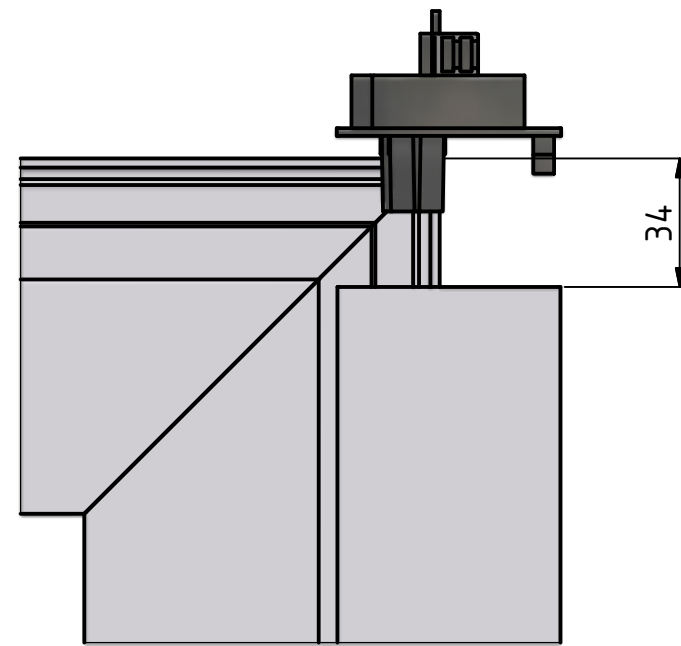
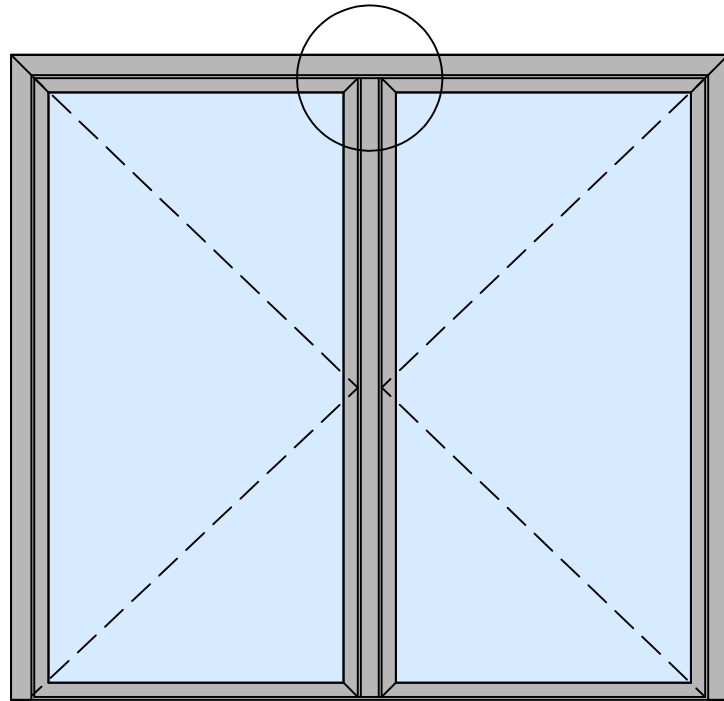

A-02-203

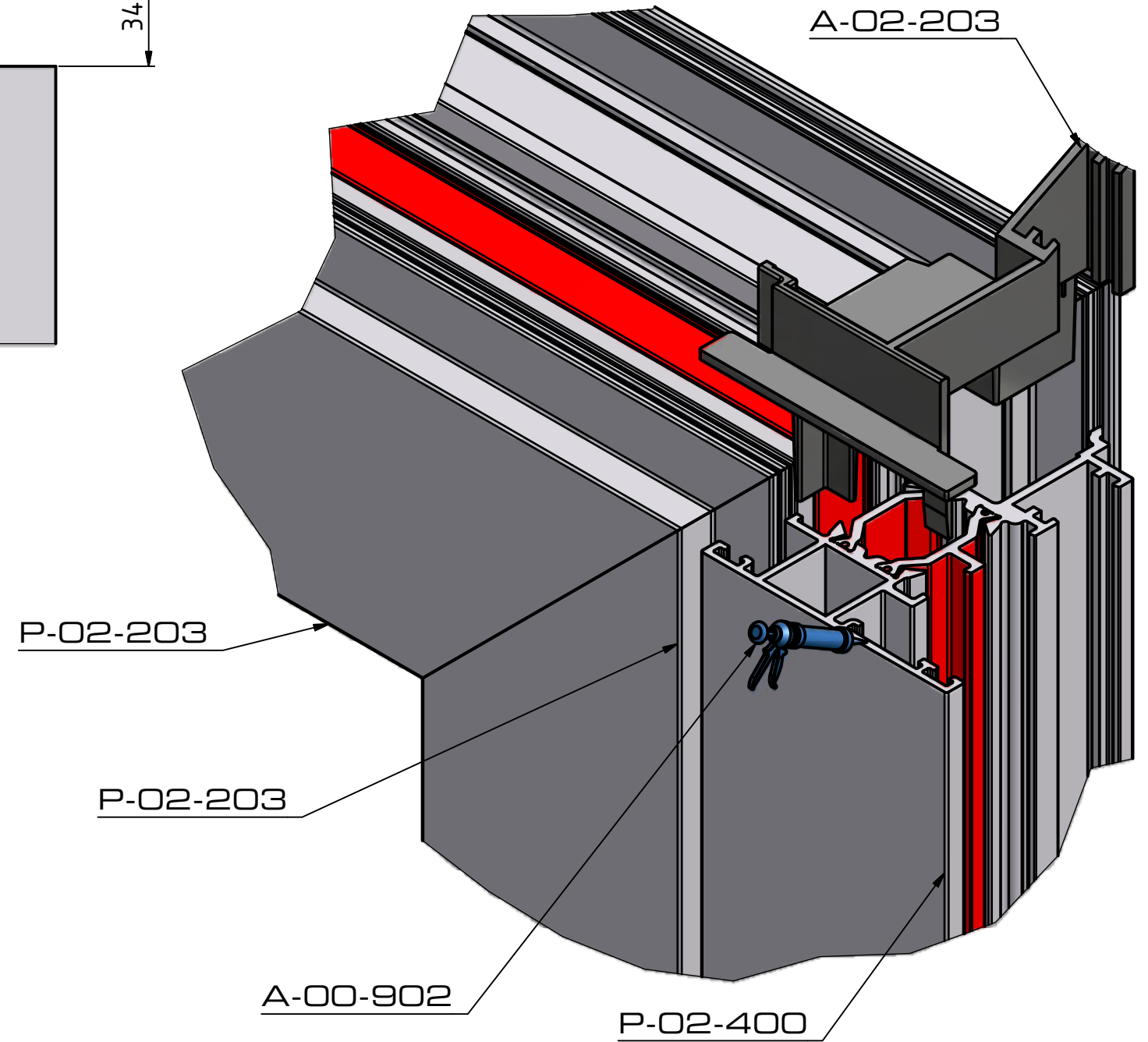

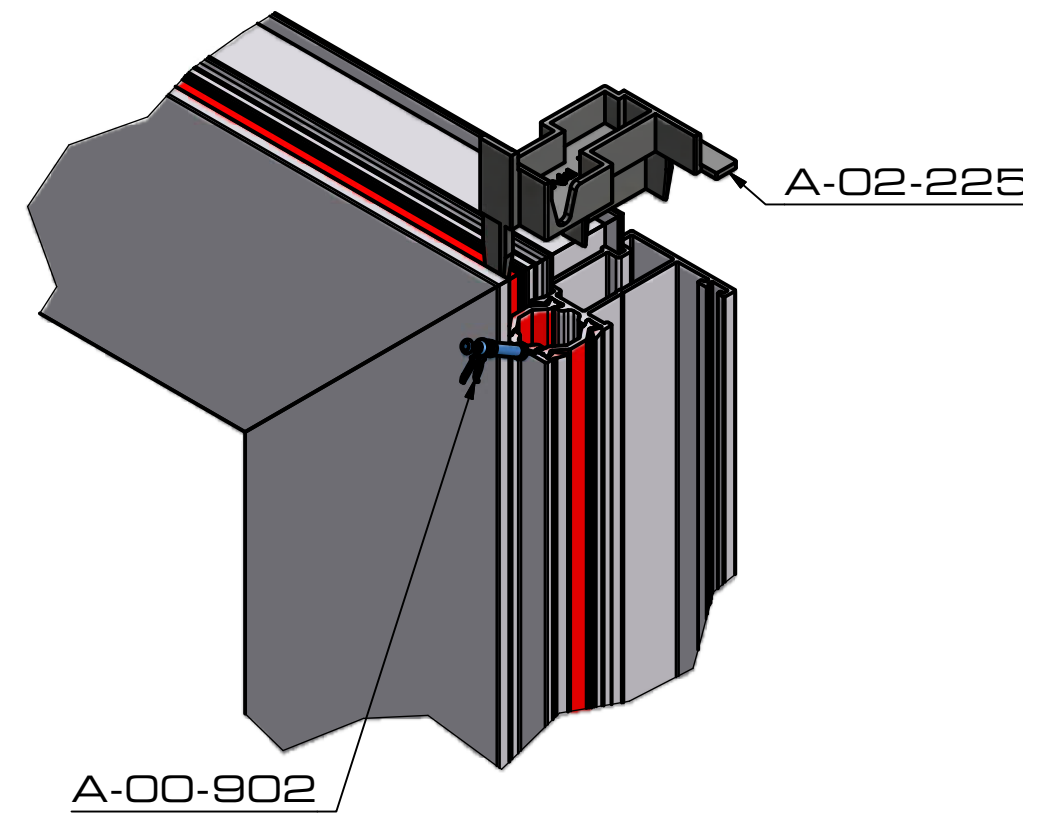
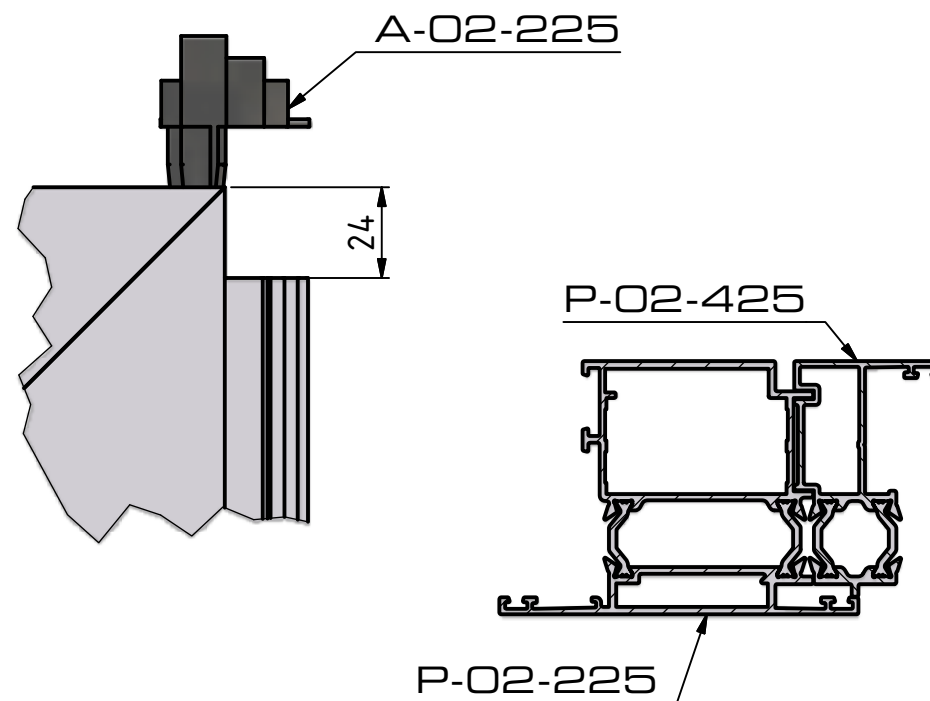
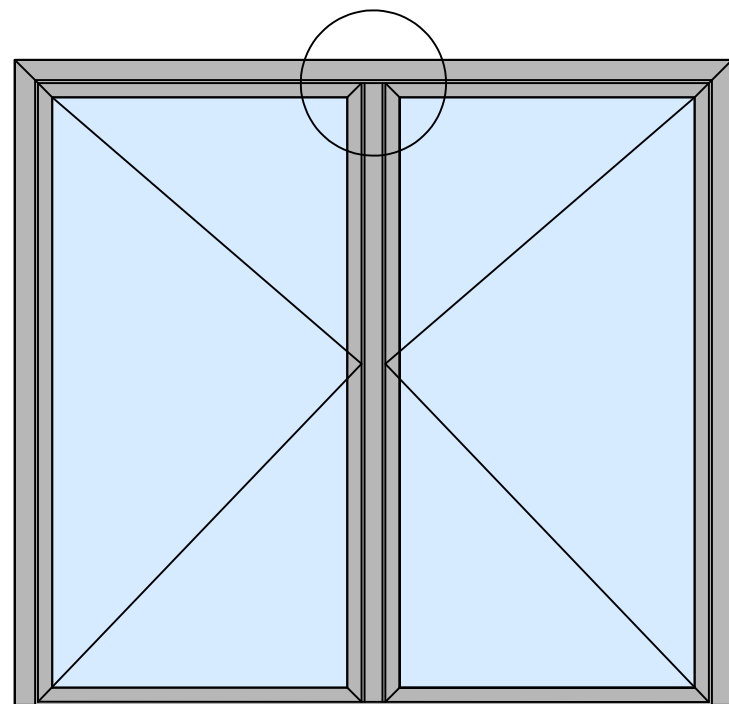
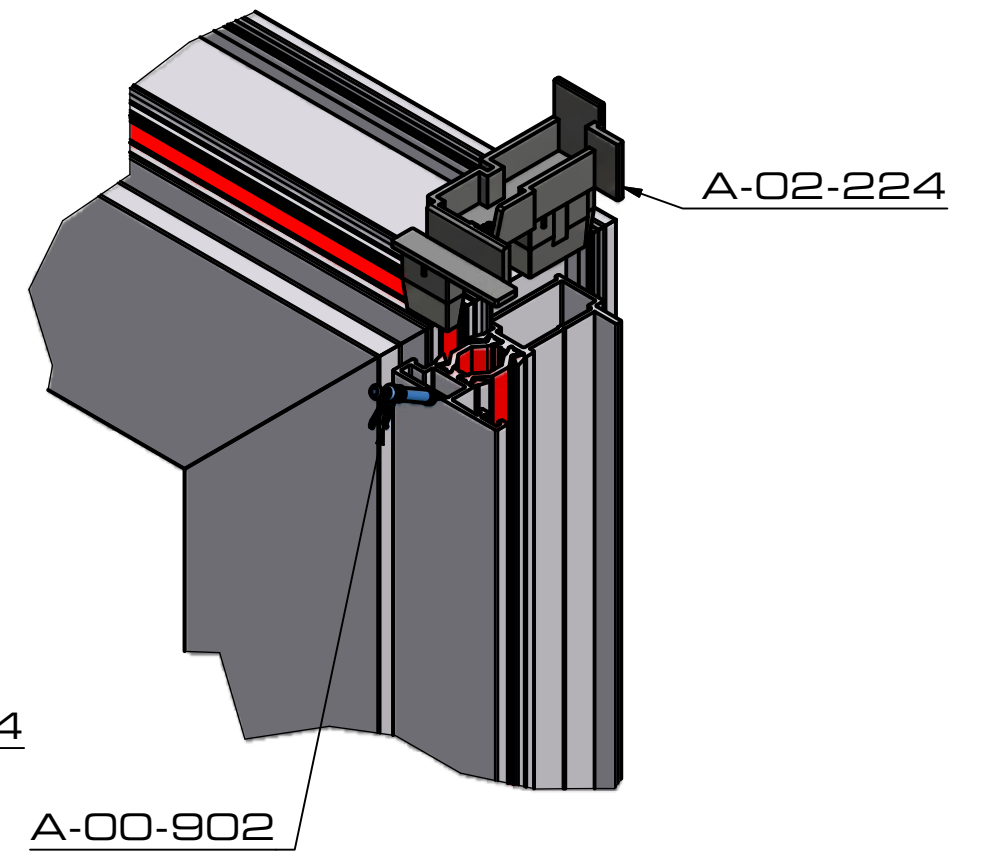
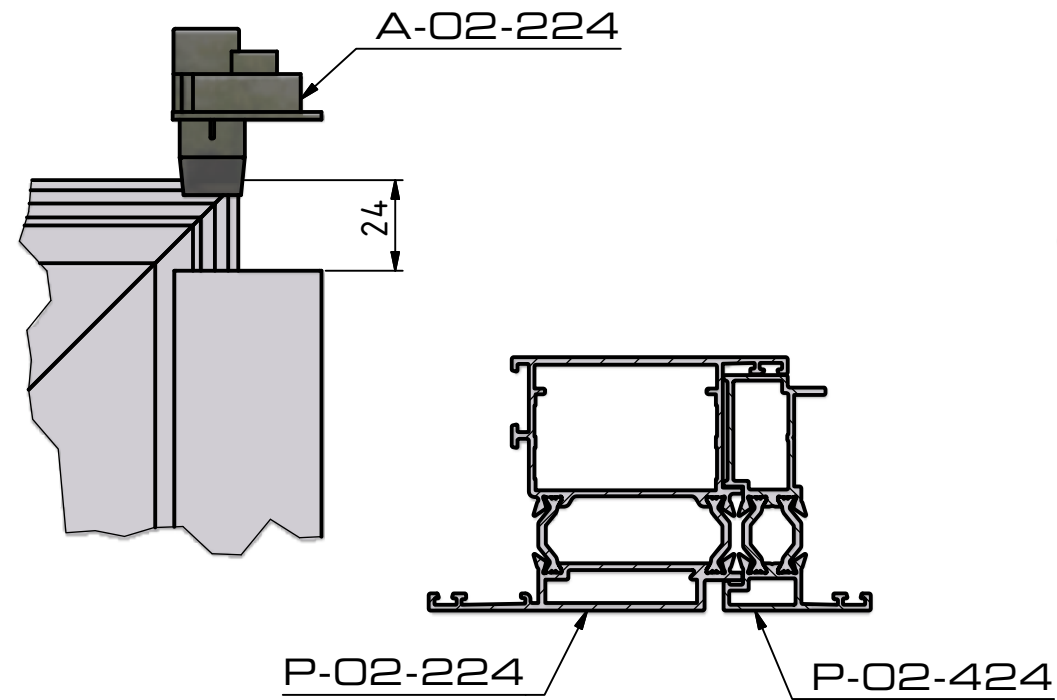
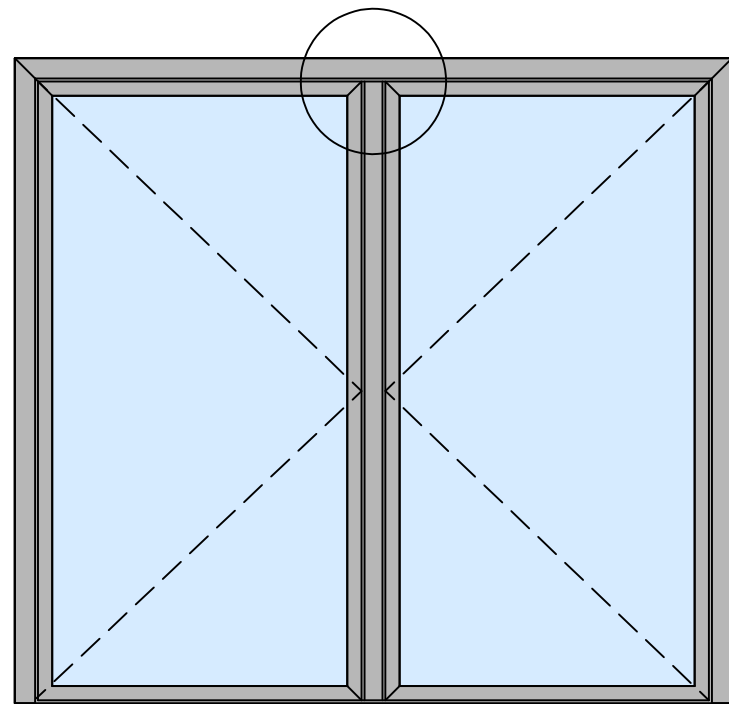

stolpeindHC_vlak.idw

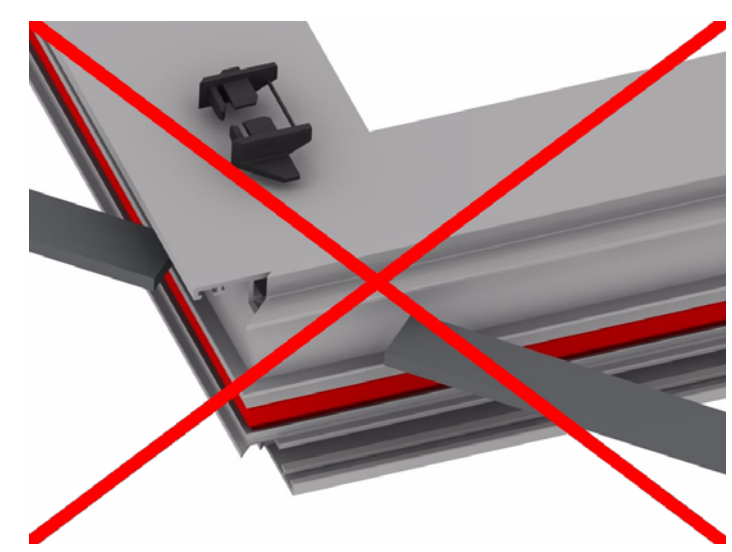
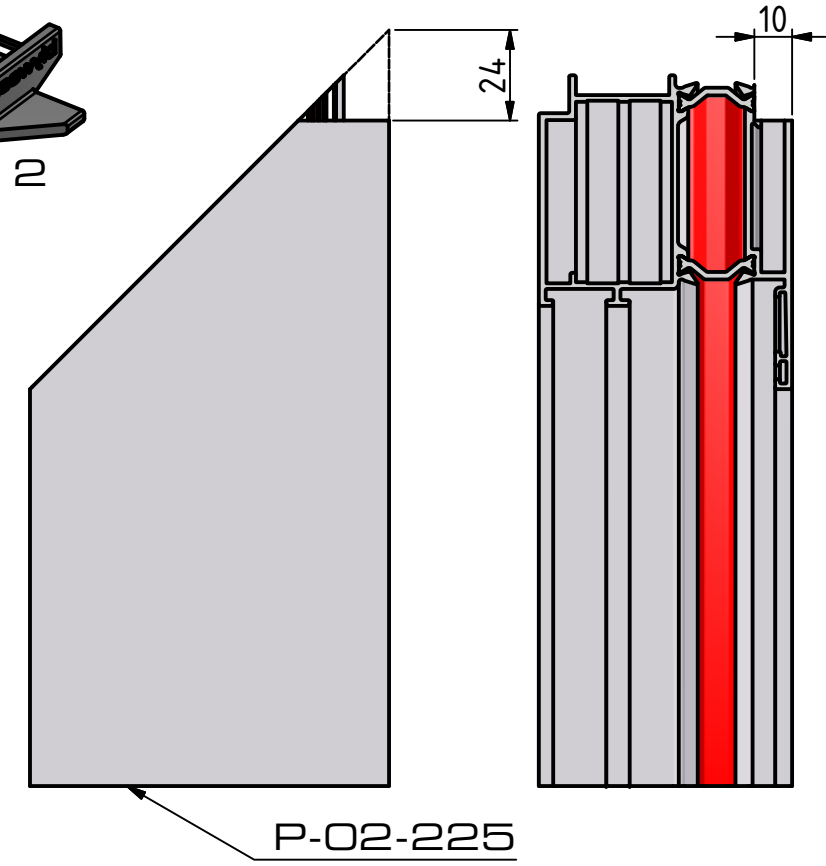
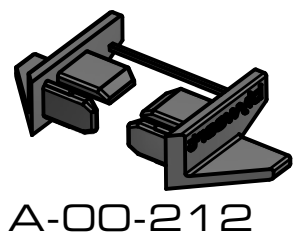
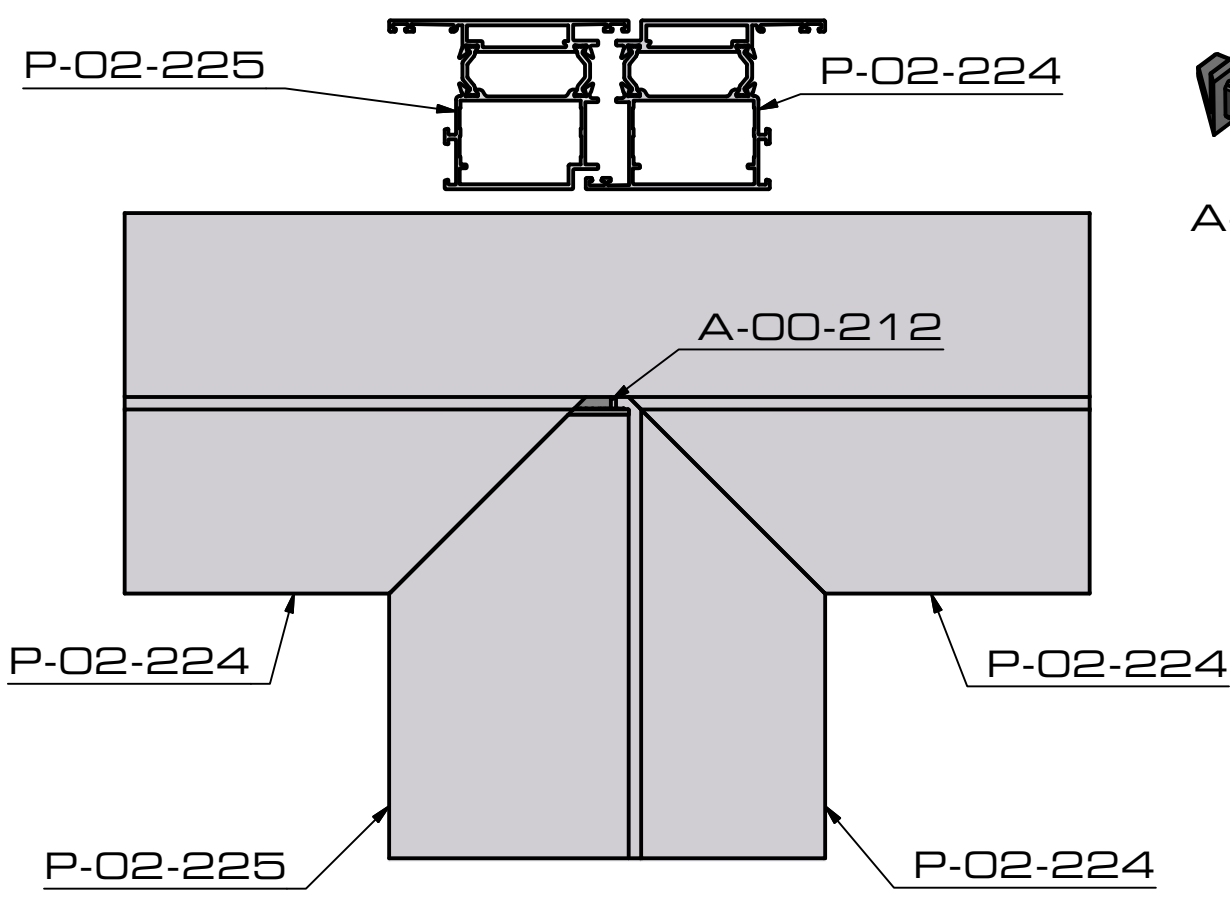
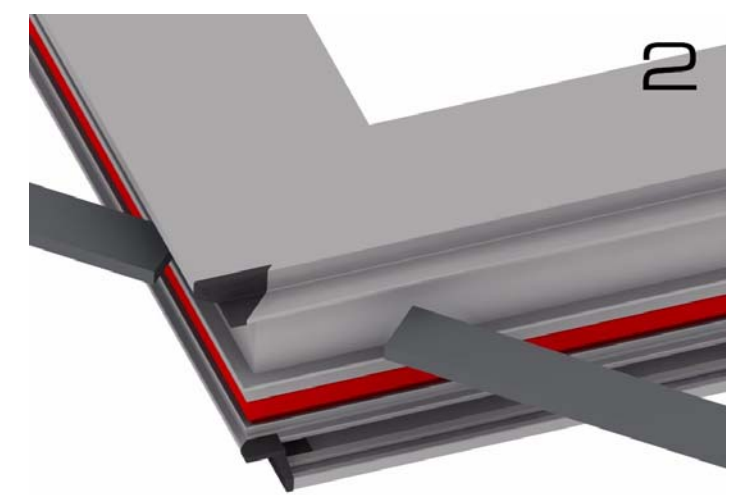
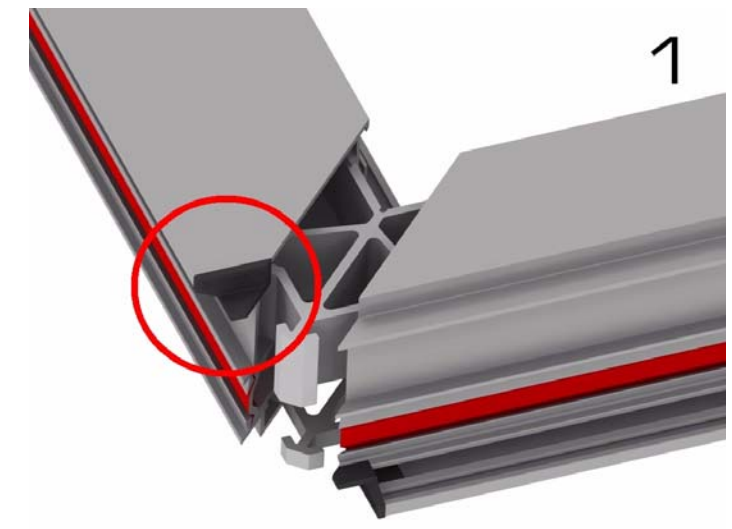
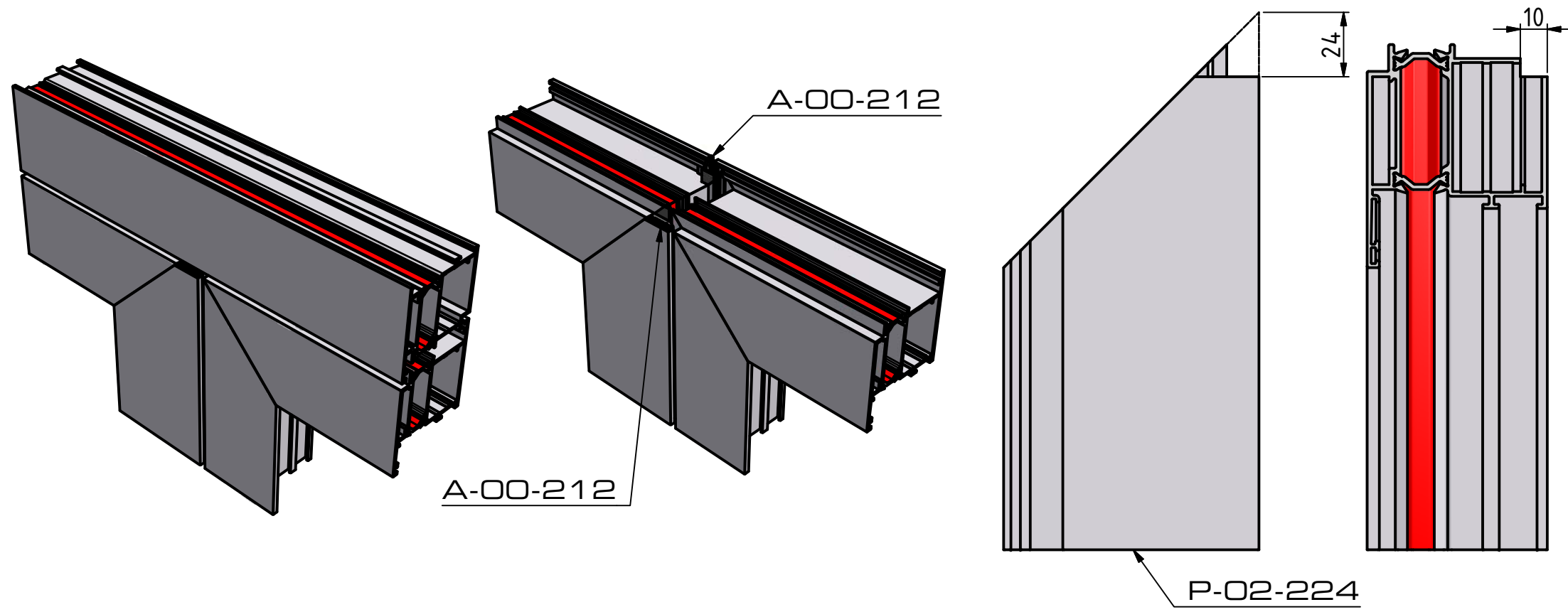

dubdeur224-225.idw

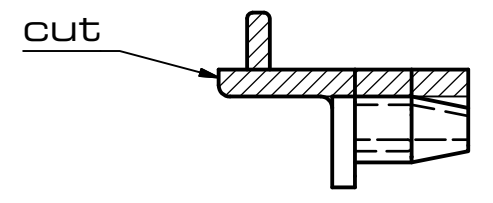
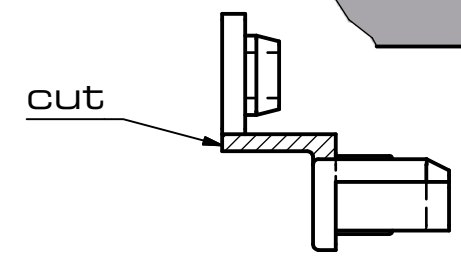
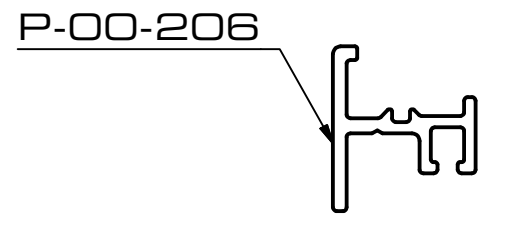
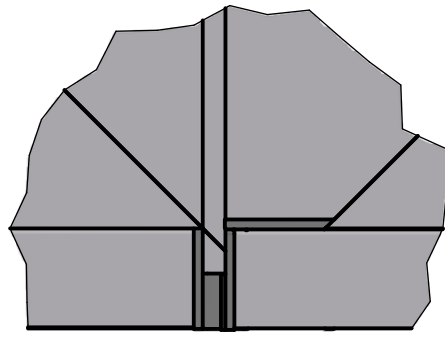
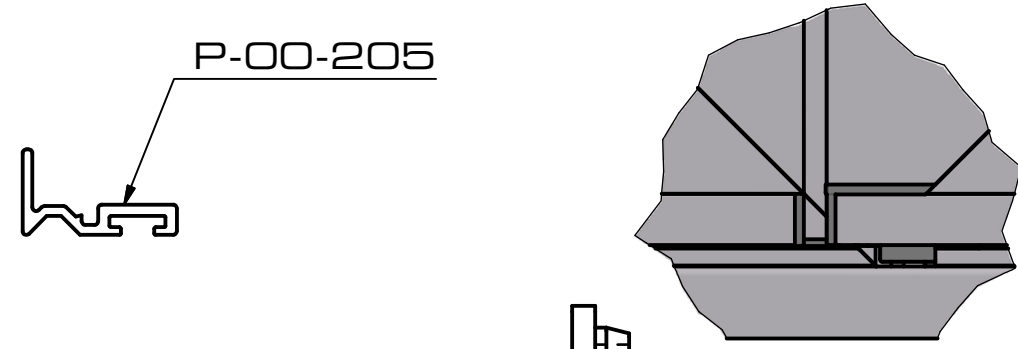
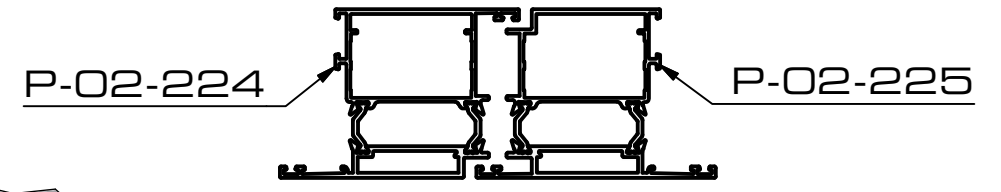
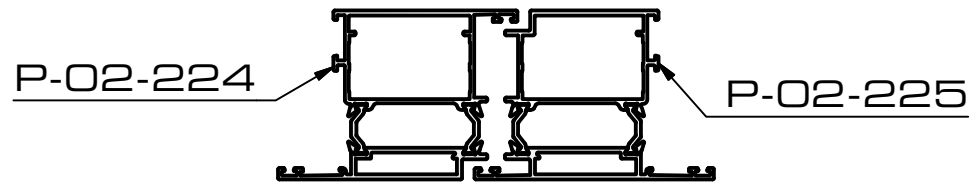
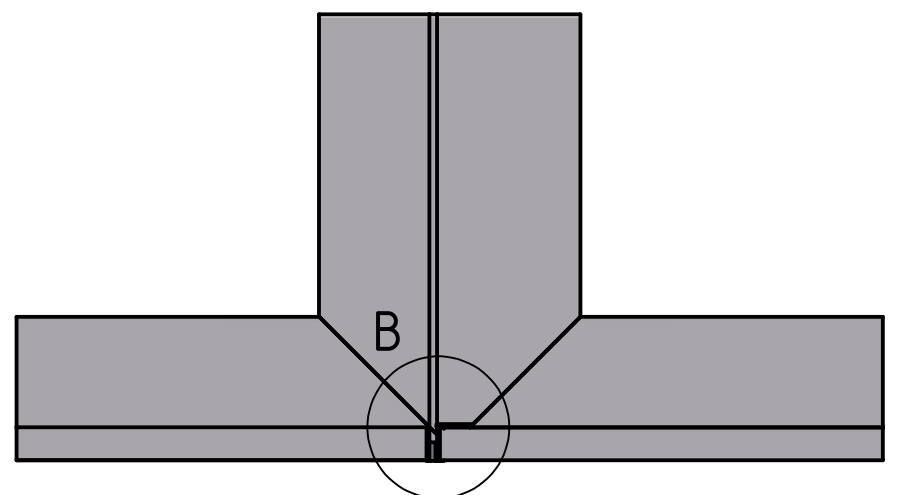
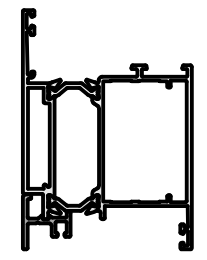
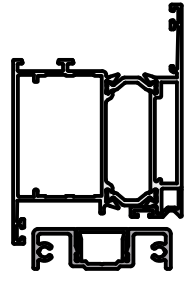
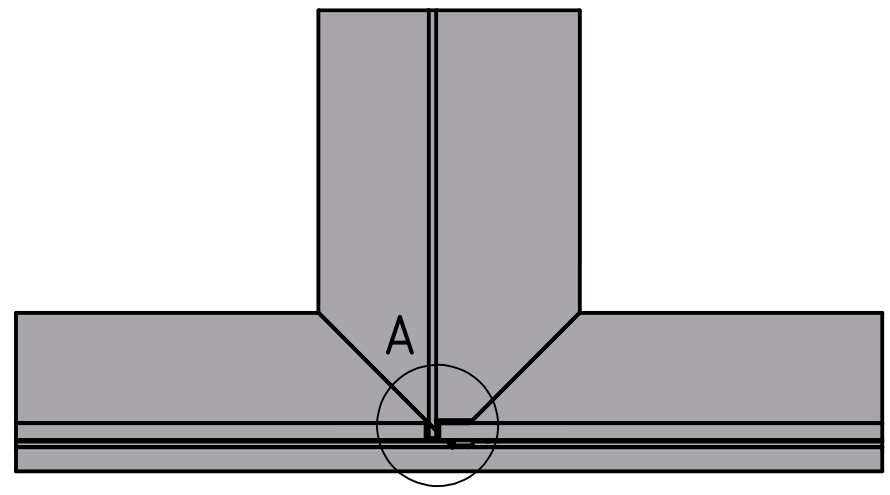

A-00-210

A-00-211



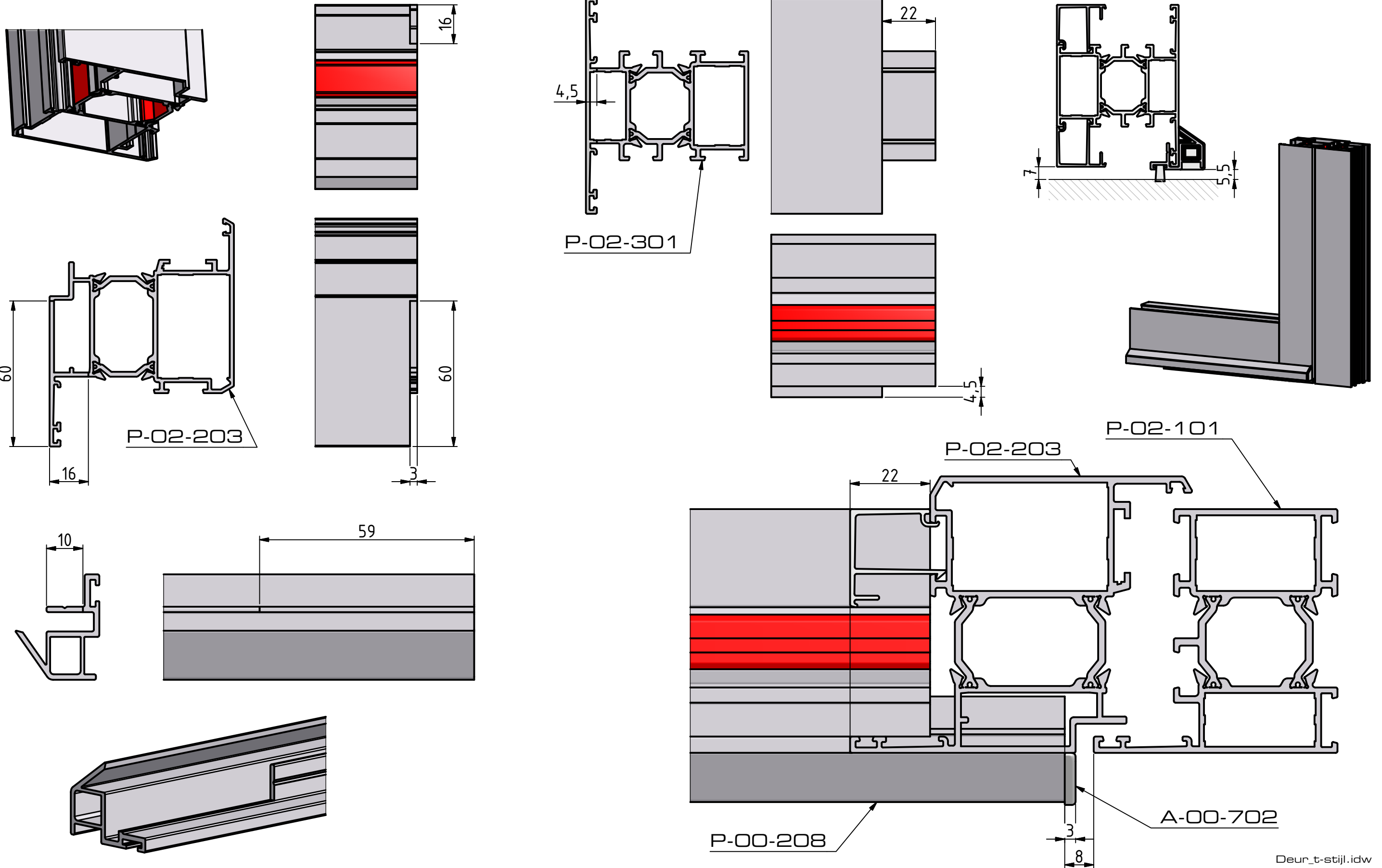

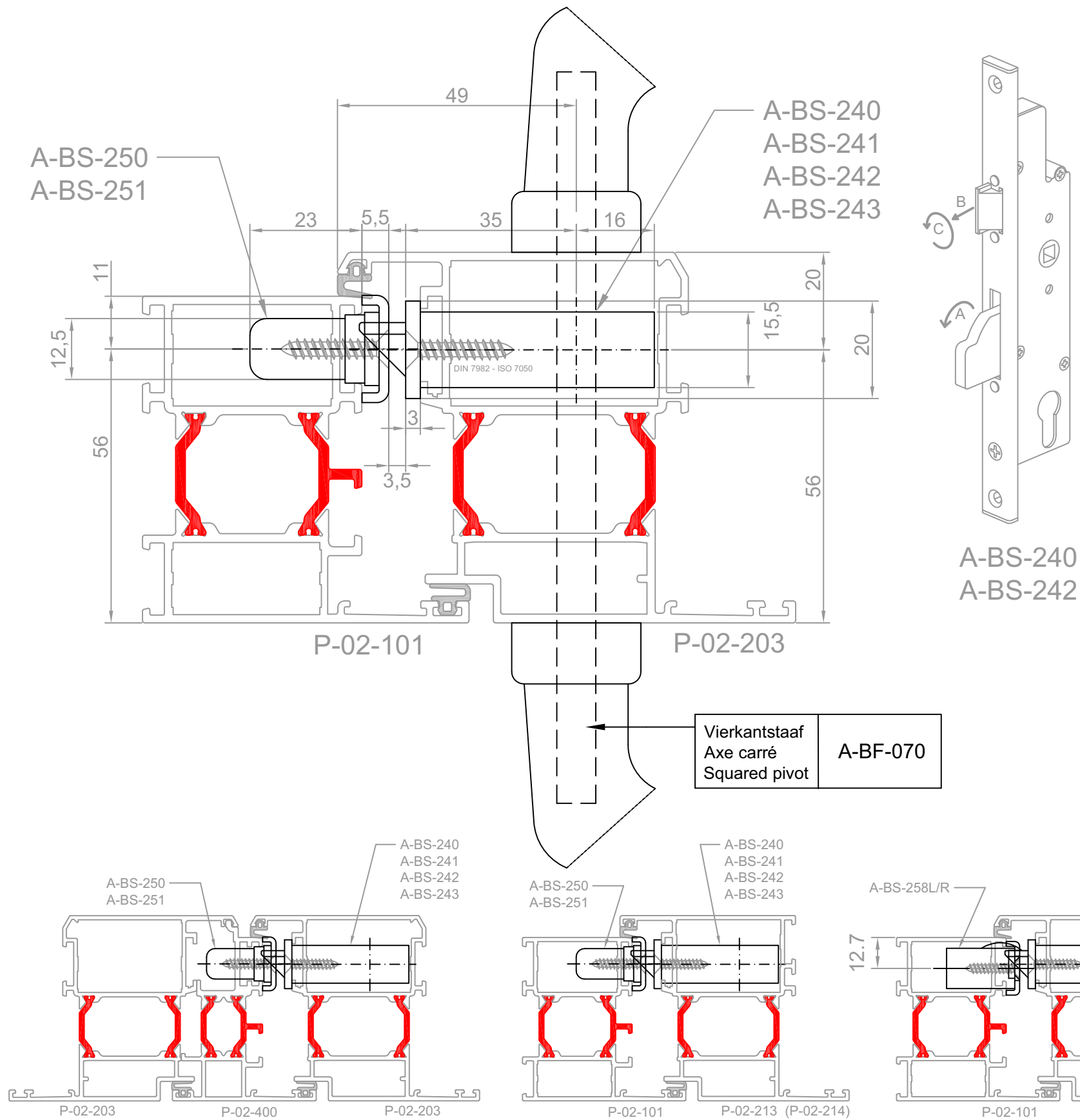

		Slottype Type serrure Locktype	Slotplaat (elektrisch) Gache (électrique) Lockplate (electric)
Penslot Serrure à pêne Lock with pen	1-punt 1-point 1-point	A-BS-240	A-BS-250 (A-BS-258L/R)
	5-punt 5-point 5-point	A-BS-242	A-BS-250 (A-BS-258L/R) A-BS-251 (2x)
Rolslot Serrure à rouleau Lock with roll	1-punt 1-point 1-point	A-BS-241	A-BS-250
	5-punt 5-point 5-point	A-BS-243	A-BS-250 A-BS-251 (2x)

		Cilinder Cylindre Cylinder	Veiligheidscil. Cyl. sécurité Safety cyl.	Cilinder 1/2 Cylindre 1/2 Cylinder 1/2
Afwerking - Finition - Finish	Zonder Sans Without	A-00-CE3055	A-00-CV3055	A-00-CE30
	Langschild Plaque longue Long plate	A-BS-252 + A-BS-253 A-00-CE3070 A-BS-254 + A-BS-255	A-00-CV3070	A-00-CE35
	Cilinderplaatje Plaque de cylindre Cylinder plate	A-00-CE3065 2 x A-BF-058	A-00-CV3065	A-00-CE30

Schroeven - Vis - Screws			
Langschild Plaque longue Long plate	A-BS-252 + A-BS-253	A-00-M5095 DIN 965 ISO 7046	M 5 x 95
Langschild Plaque longue Long plate	SKG A-BS-254 + A-BS-255	A-00-M6095 DIN 965 ISO 7046	M 6 x 95
Dubbele kruk + anti krukdiefstal Béquille double + anti béquille vole Dobble handle + anti handle theft	A-BF-057 + A-BF-069 (2x)	A-00-M5090 DIN 965 ISO 7046	M 5 x 90

HCdeur_binnen.dwg

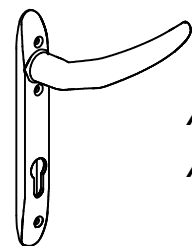
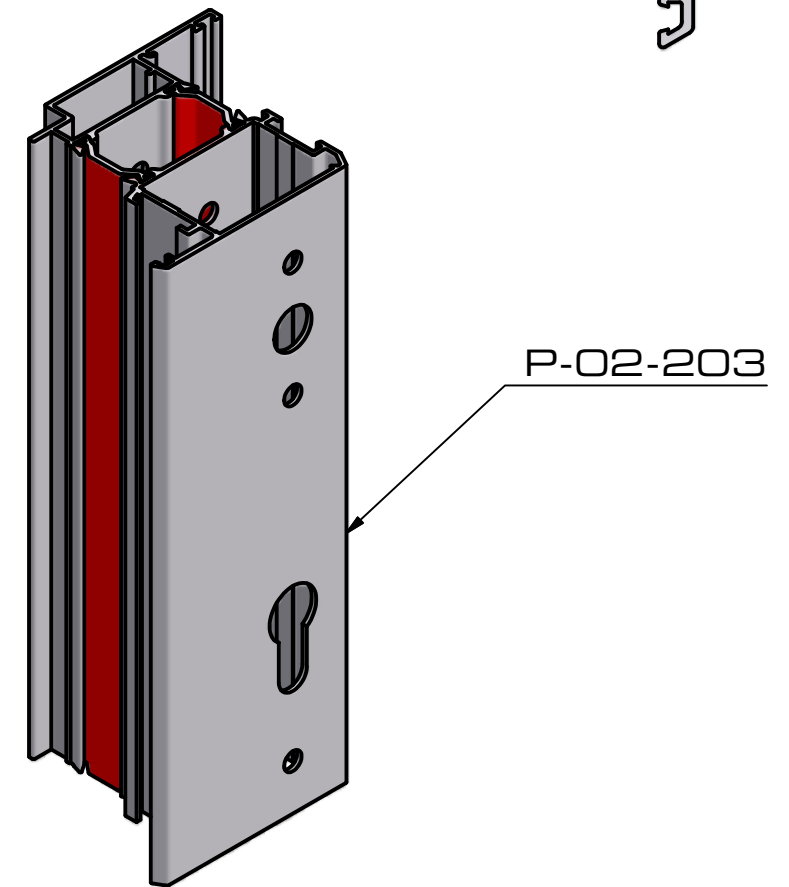
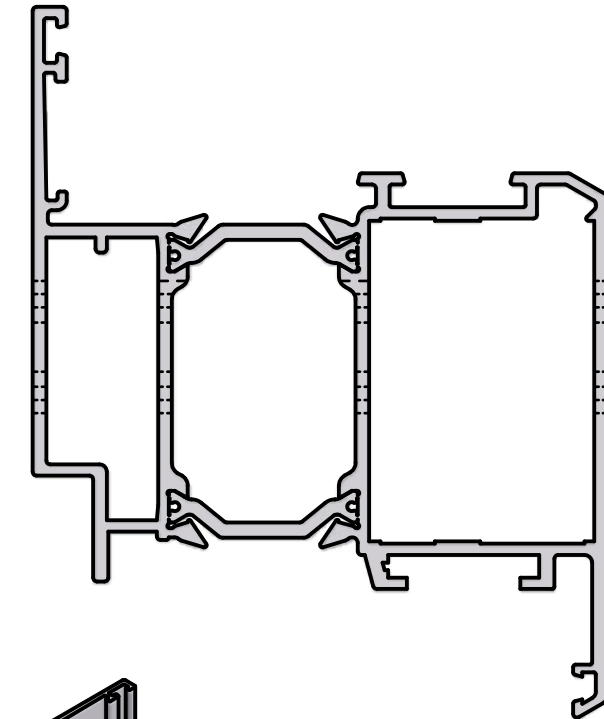
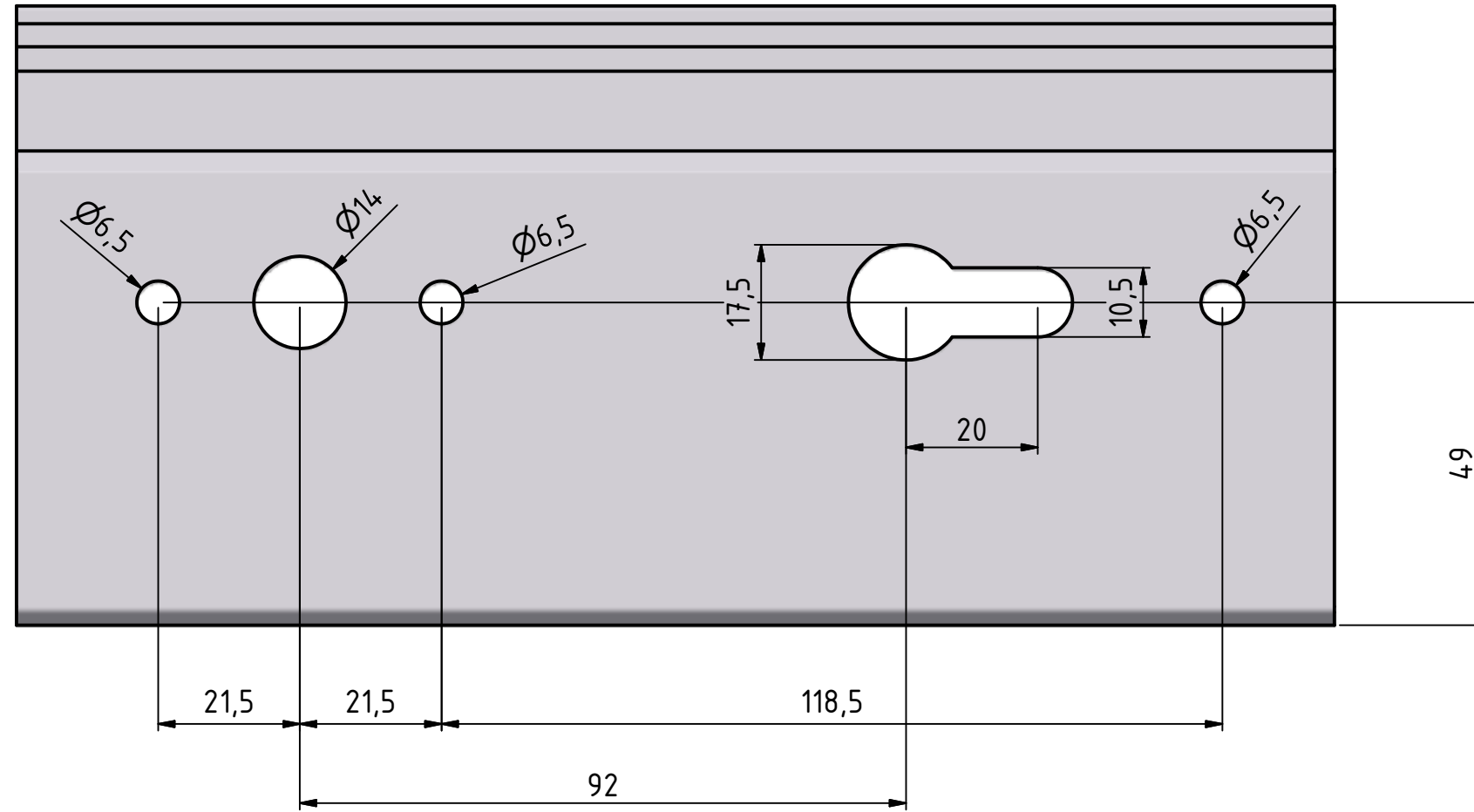

A-BS-252
A-BS-253

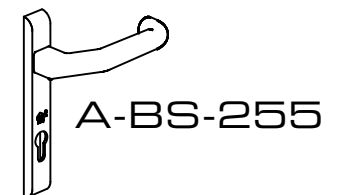
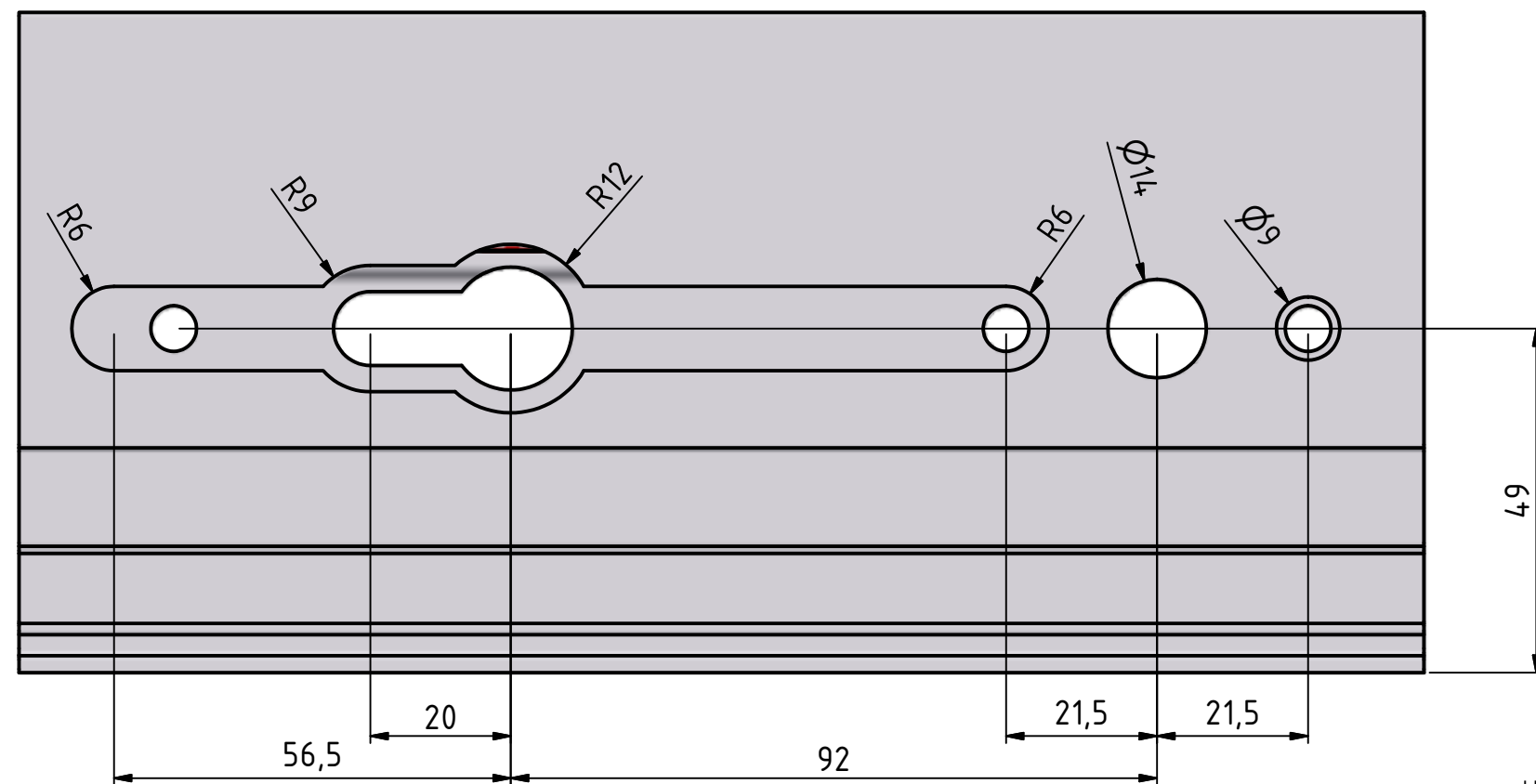
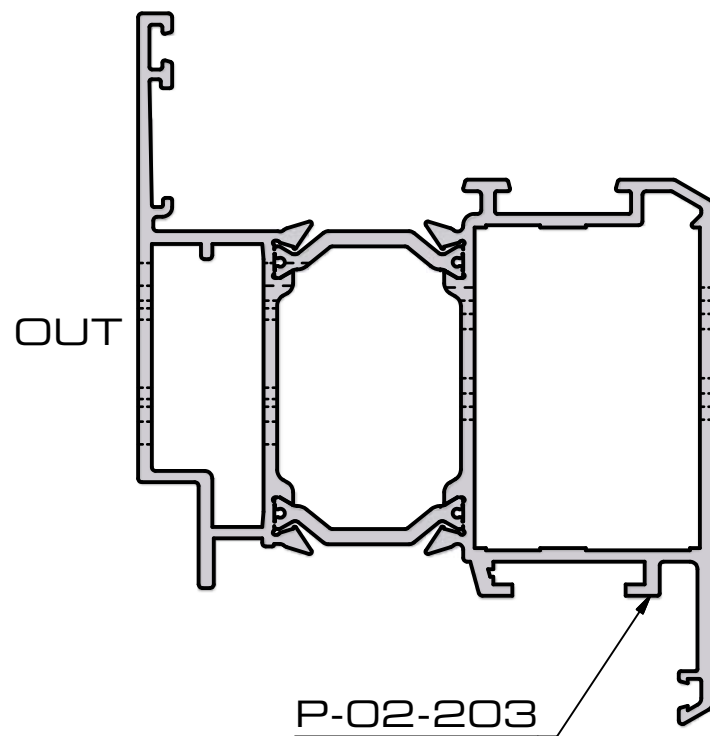
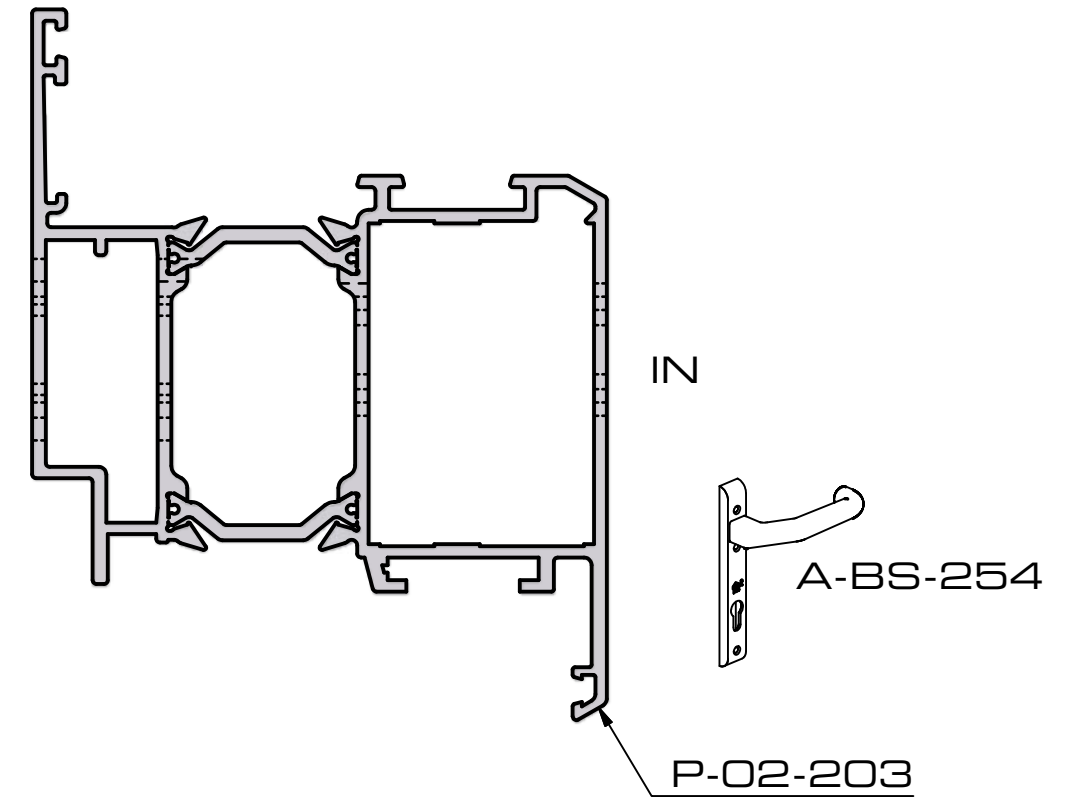
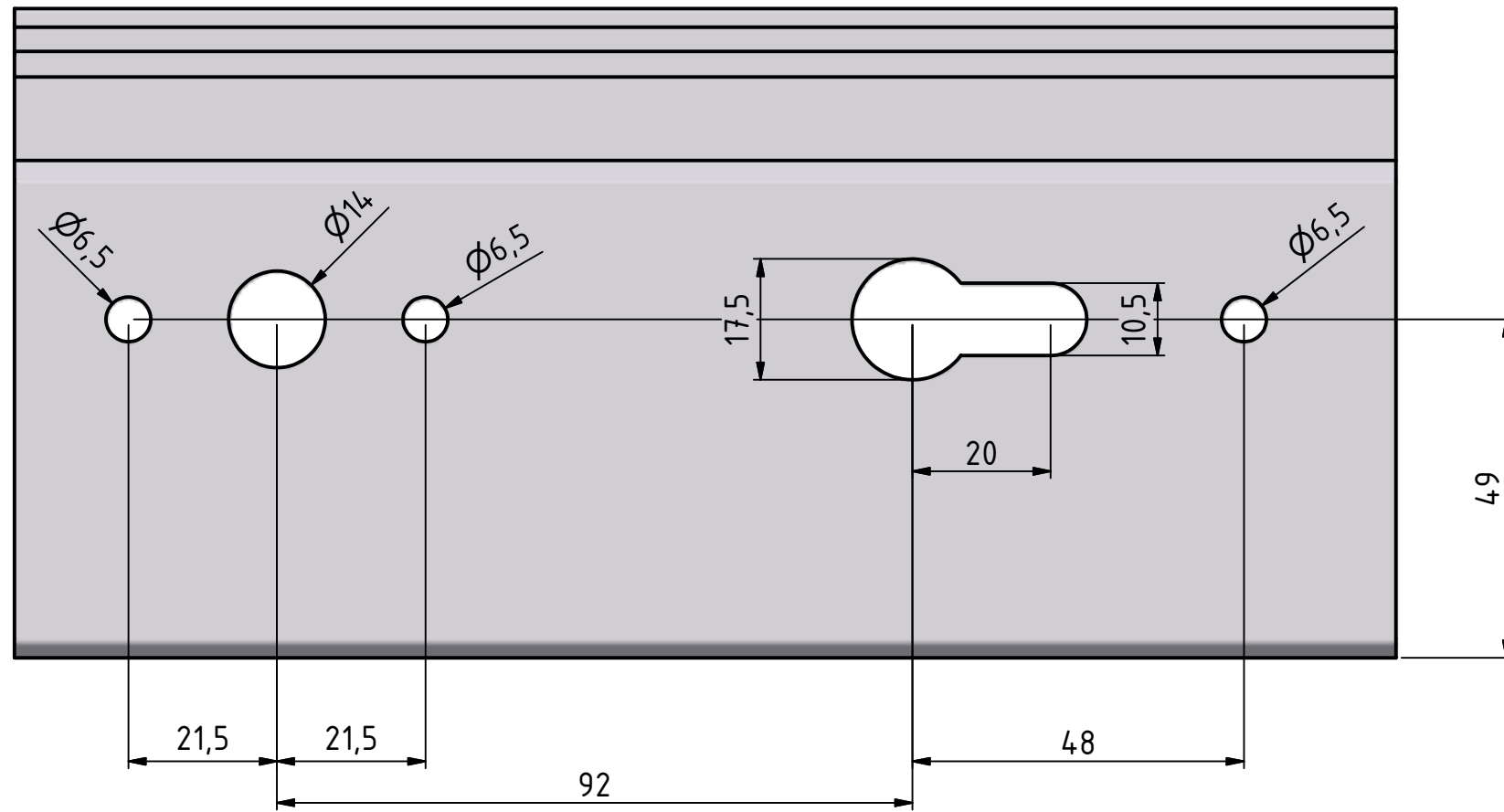

uitfrezing_deurkrukSKG.idw

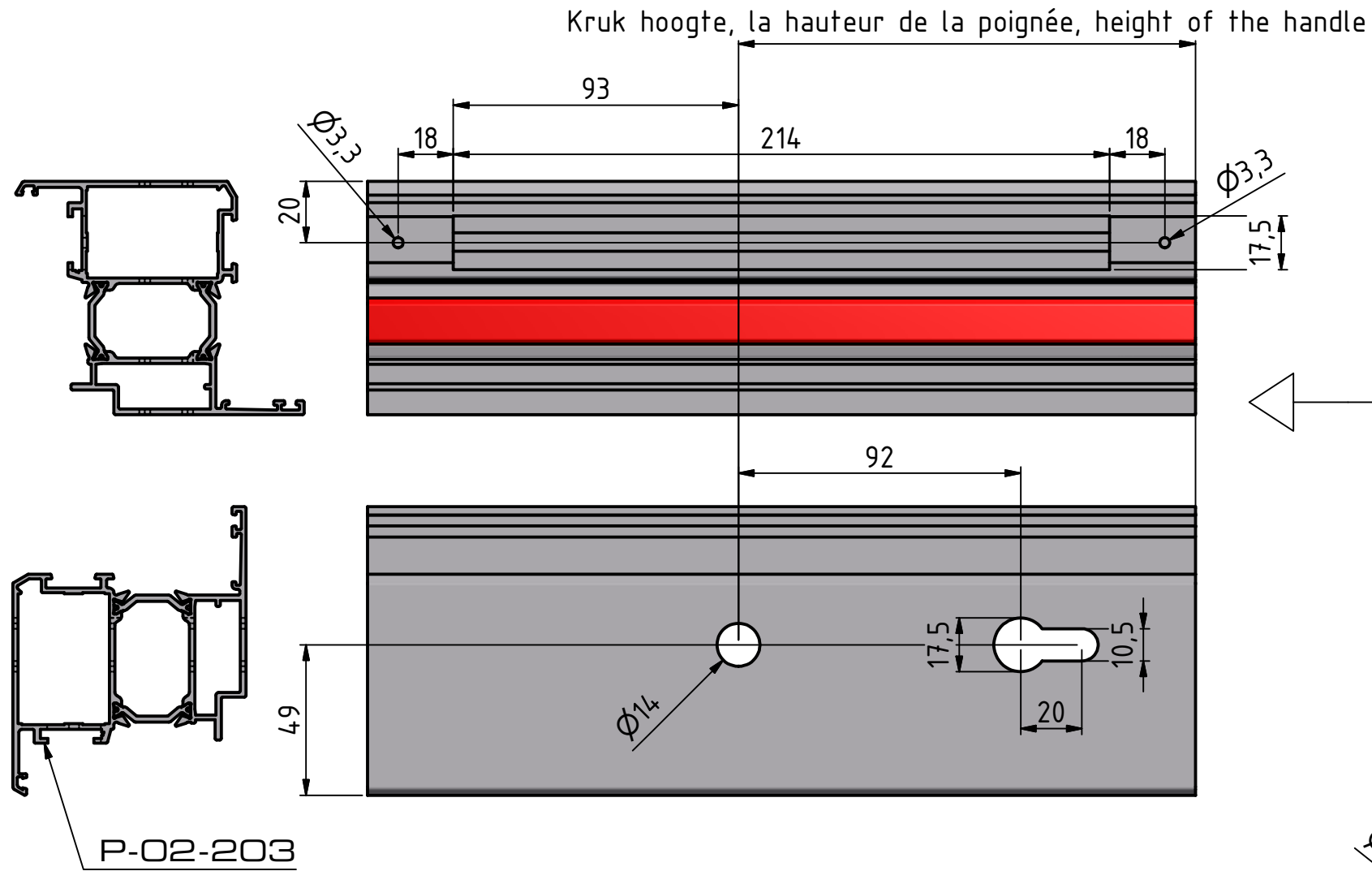

Voor	P-02-203	
Pour	P-02-213	
For	P-02-214	

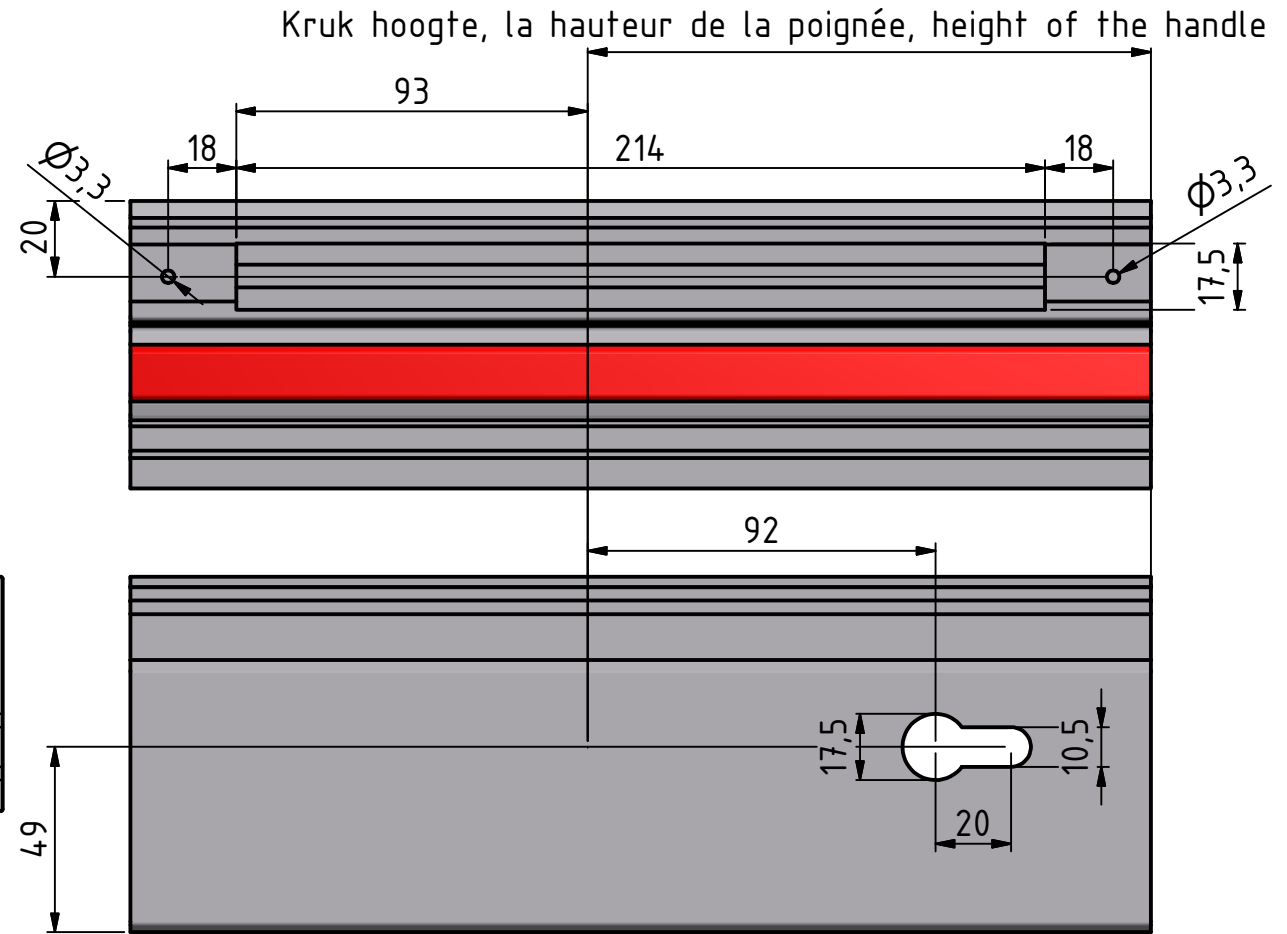
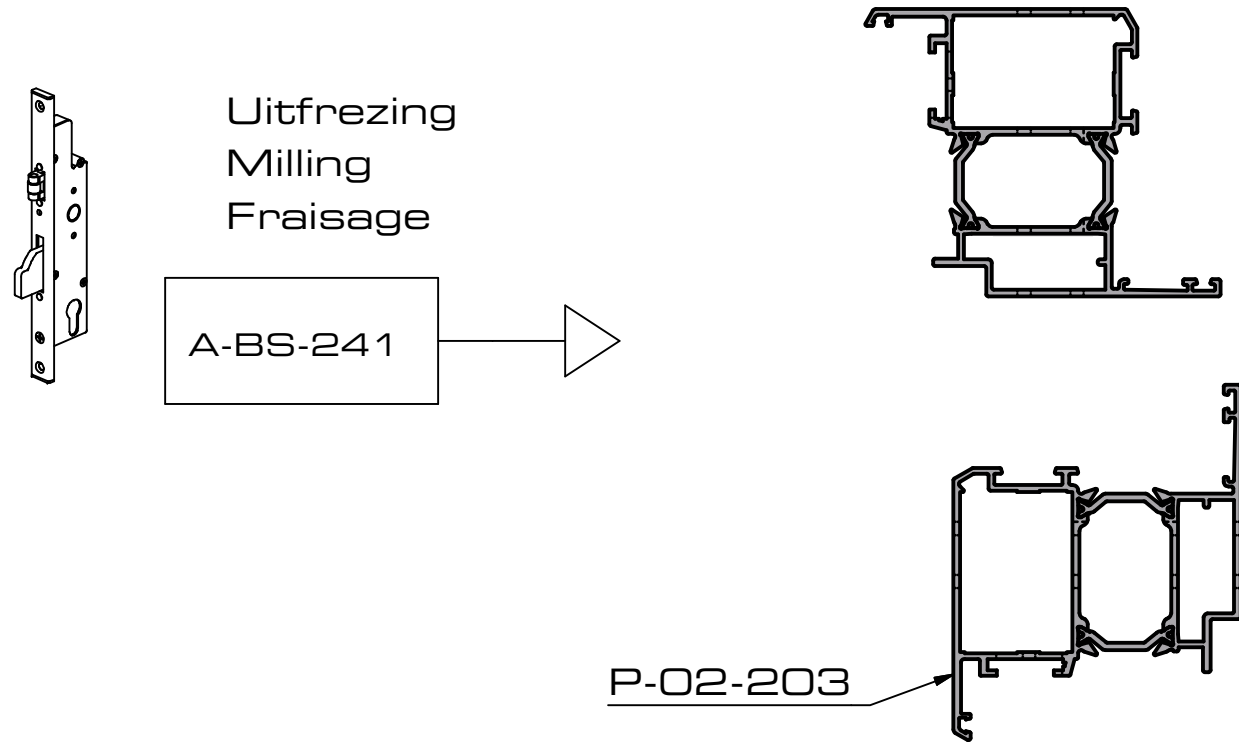



Ø7: M5x12,5
DIN 965 M5x25

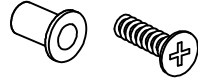

Ø3,3: DIN 7982 4,2x16



Uitfrezing
Milling
Fraisage

A-BS-242
A-BS-243



Voor

P-02-203

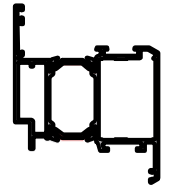

Pour

P-02-213

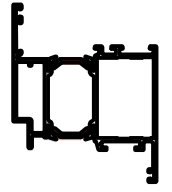

For

P-02-214

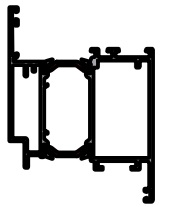

Kruk hoogte vanaf vloerpas, min 1077 mm
la hauteur de la poignée a partir du sol, min 1077 mm
height of the handle from the floor, min 1077 mm

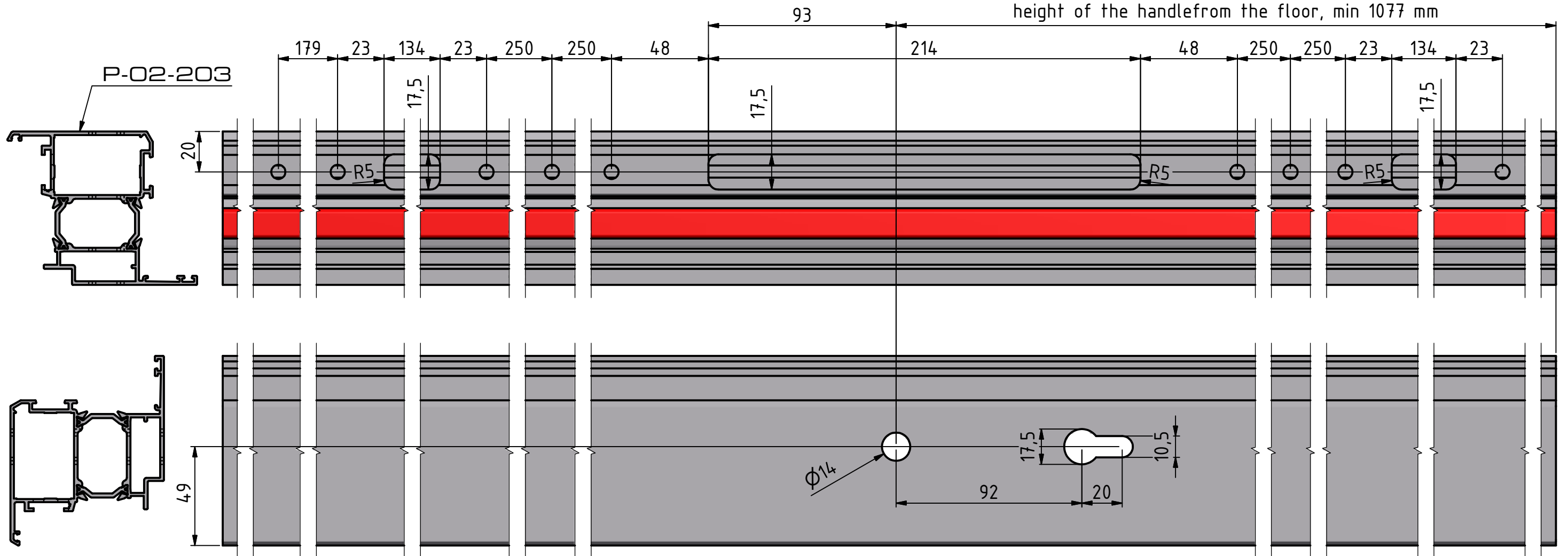

Litfrezingslot.idw

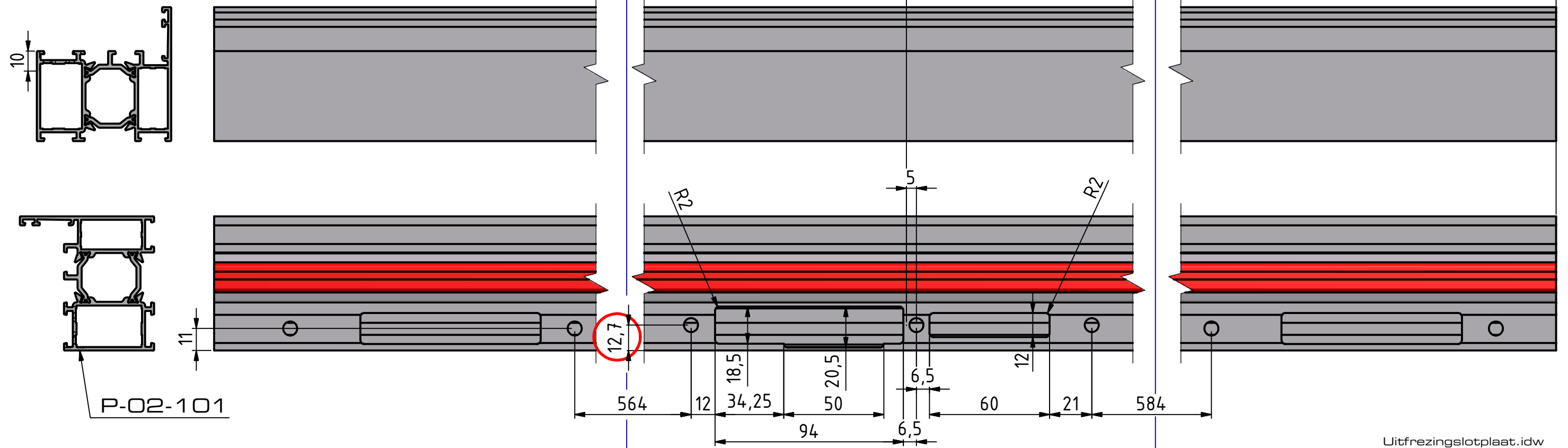
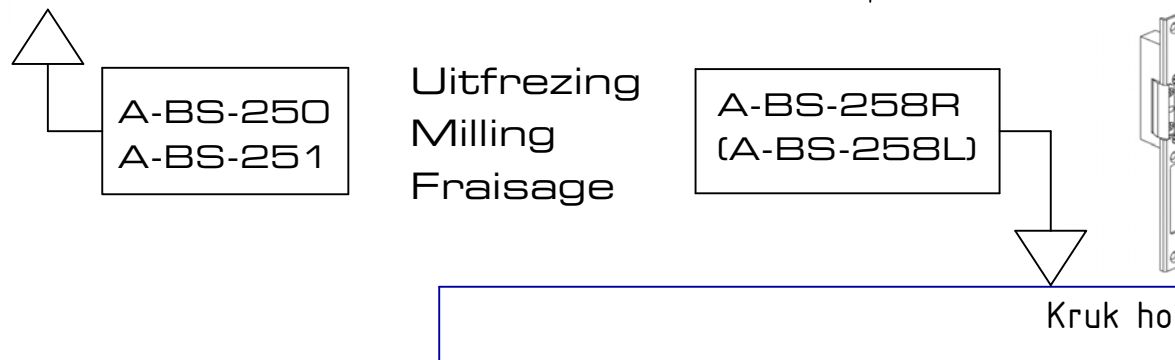
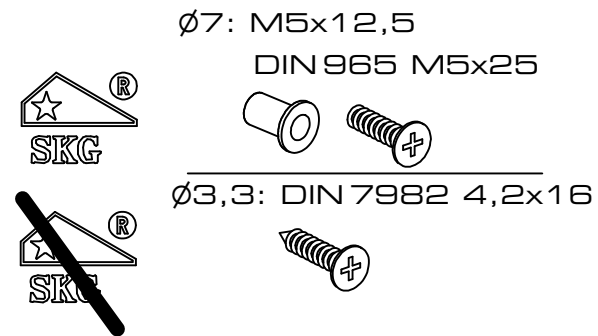
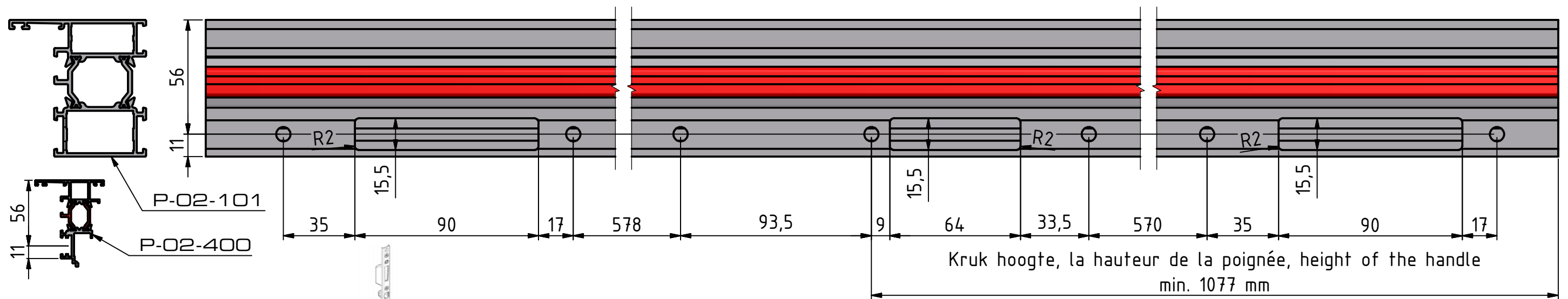

Uitfrezingslotplaat.idw

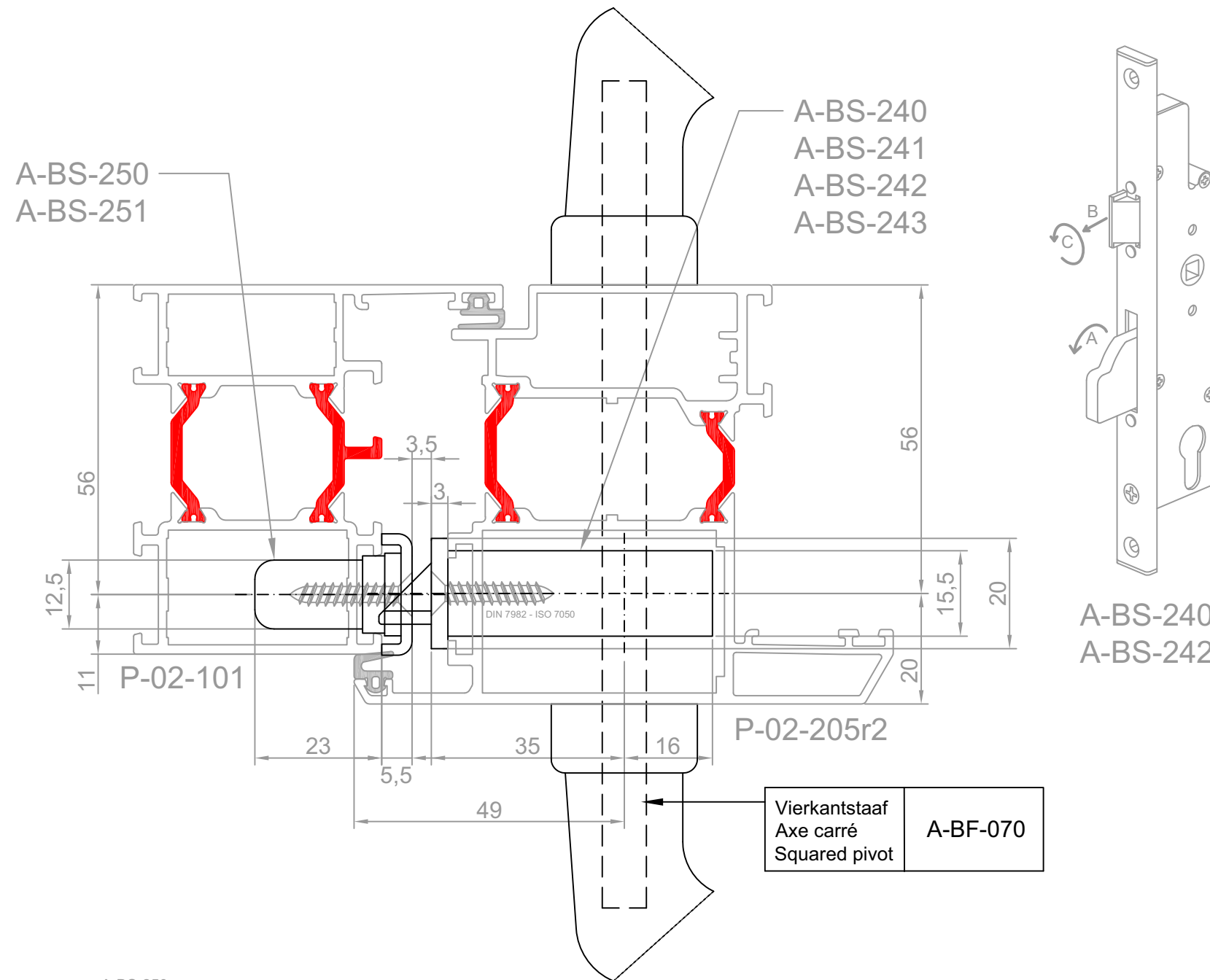

		Slottype Type serrure Locktype	Slotplaat (elektrisch) Gache (électrique) Lockplate (electric)
Penslot Serrure à pêne Lock with pen	1-punt 1-point 1-point	A-BS-240	A-BS-250 (A-BS-258L/R)
	5-punt 5-point 5-point	A-BS-242	A-BS-250 (A-BS-258L/R) A-BS-251 (2x)
Rolslot Serrure à rouleau Lock with roll	1-punt 1-point 1-point	A-BS-241	A-BS-250
	5-punt 5-point 5-point	A-BS-243	A-BS-250 A-BS-251 (2x)

		Cilinder Cylindre Cylinder	Veiligheidscil. Cyl. sécurité Safety cyl.	Cilinder 1/2 Cylindre 1/2 Cylinder 1/2
Afwerking - Finition - Finish	Zonder Sans Without	----	----	A-00-CE55
	Langschild Plaque longue Long plate	A-BS-252 + A-BS-253 A-BS-254 + A-BS-255	A-00-CE3070	A-00-CV3070 A-00-CE70
	Cilinderplaatje Plaque de cylindre Cylinder plate	2 x A-BF-058	A-00-CE3065	A-00-CV3065 A-00-CE65

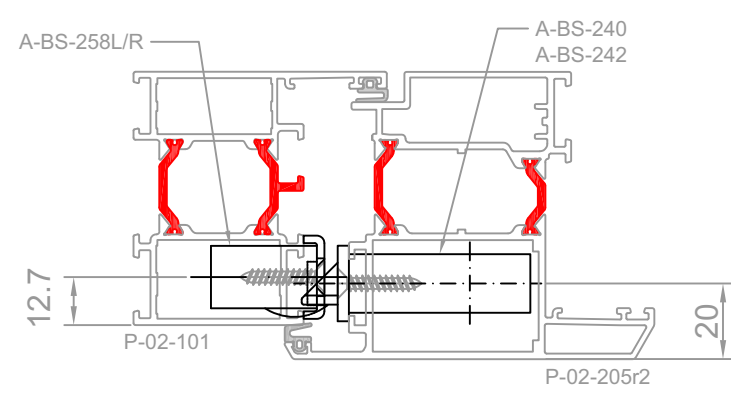
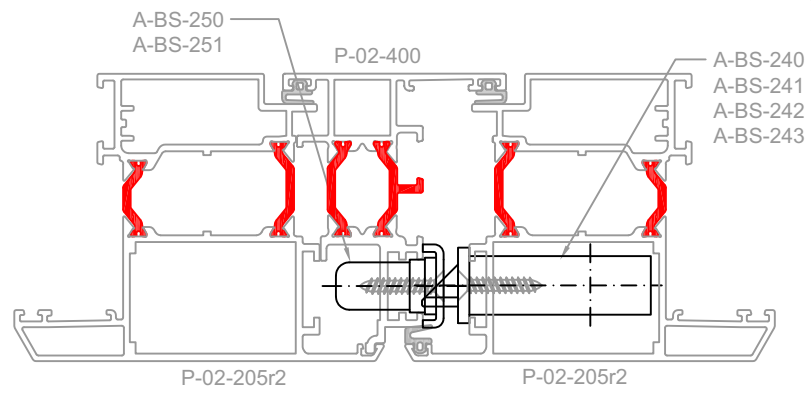

Schroeven - Vis - Screws			
Langschild Plaque longue Long plate	A-BS-252 + A-BS-253	A-00-M5095	DIN 965 ISO 7046 M 5 x 95
Langschild Plaque longue Long plate	SKG A-BS-254 + A-BS-255	A-00-M6095	DIN 965 ISO 7046 M 6 x 95
Dubbele kruk + anti krukdiefstal Béquille double + anti béquille vole Dobble handle + anti handle theft	A-BF-057 + A-BF-069 (2x)	A-00-M5090	DIN 965 ISO 7046 M 5 x 90

HCdeur_buiten.dwg

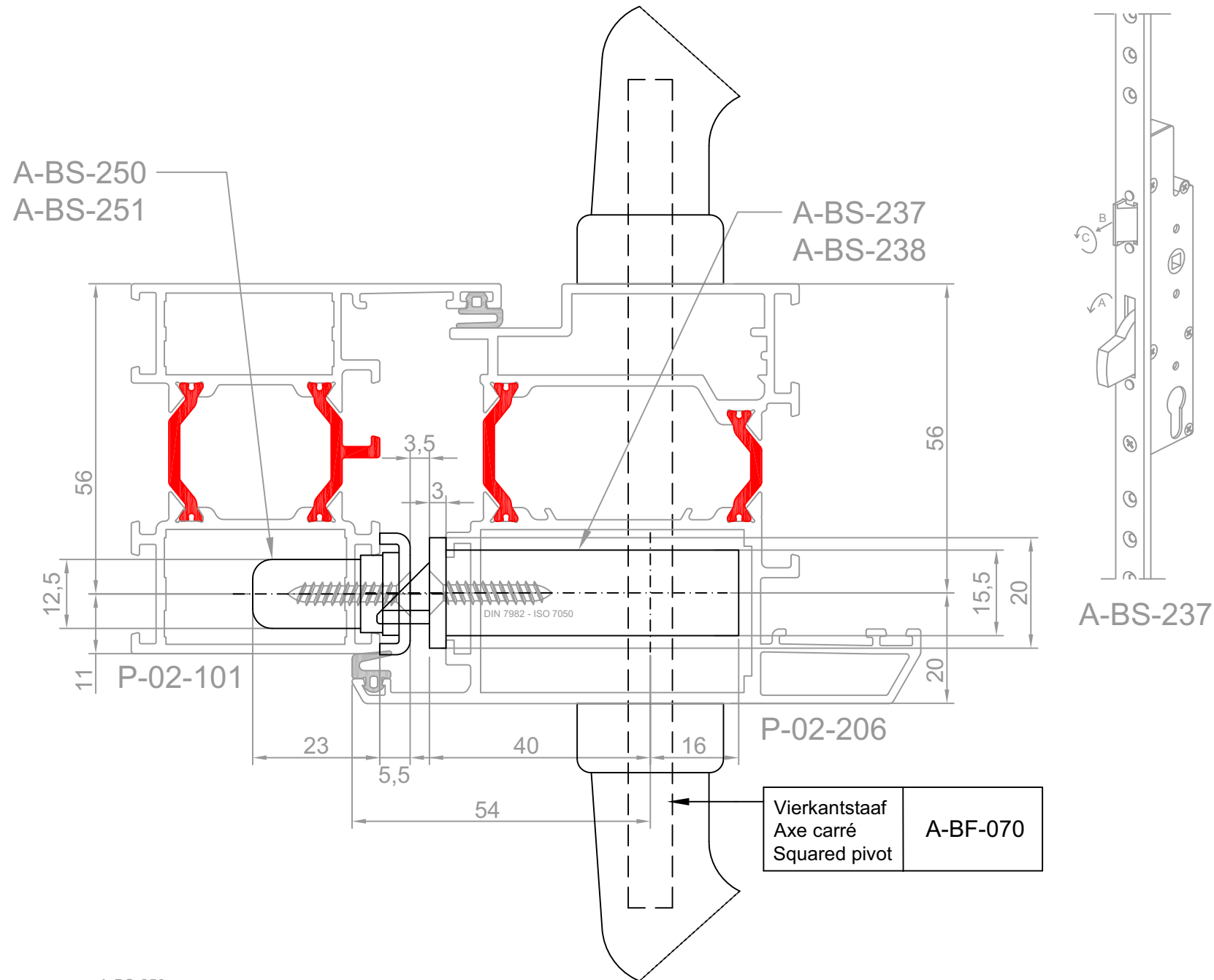

		Slottype Type serrure Locktype	Slotplaat (elektrisch) Gache (électrique) Lockplate (electric)
Penslot Serrure à pêne Lock with pen	1-punt 1-point 1-point	-----	-----
	5-punt 5-point 5-point	A-BS-237	A-BS-250 (A-BS-258L/R) A-BS-251 (2x)
Rolslot Serrure à rouleau Lock with roll	1-punt 1-point 1-point	-----	-----
	5-punt 5-point 5-point	A-BS-238	A-BS-250 A-BS-251 (2x)

		Cilinder Cylindre Cylinder	Veiligheids cil. Cyl. sécurité Safety cyl.	Cilinder 1/2 Cylindre 1/2 Cylinder 1/2
Afwerking - Finition - Finish	Zonder Sans Without	-----	-----	A-00-CE55
	Langschild Plaque longue Long plate	A-00-CE3070	A-00-CV3070	A-00-CE70
	Cilinderplaatje Plaque de cylindre Cylinder plate 2 x A-BF-058	A-00-CE3065	A-00-CV3065	A-00-CE65

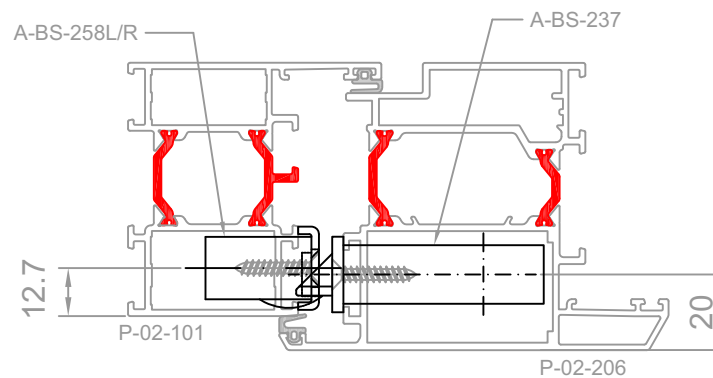
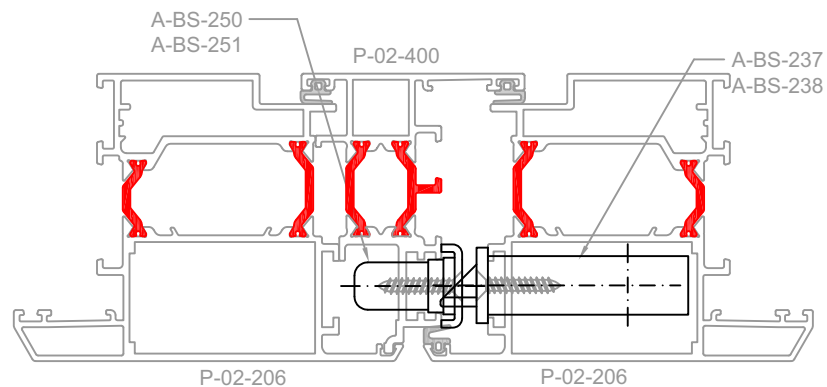

Schroeven - Vis - Screws			
Langschild Plaque longue Long plate	A-BS-252 + A-BS-253	A-00-M5095	DIN 965 ISO 7046 M 5 x 95
Langschild Plaque longue Long plate	SKG A-BS-254 + A-BS-255	A-00-M6095	DIN 965 ISO 7046 M 6 x 95
Dubbele kruk + anti krukdiefstal Béquille double + anti béquille vole Dobble handle + anti handle theft	A-BF-057 + A-BF-069 (2x)	A-00-M5090	DIN 965 ISO 7046 M 5 x 90

HCdeur_buiten_206.dwg

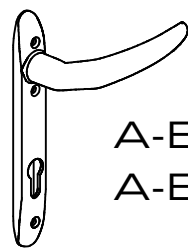
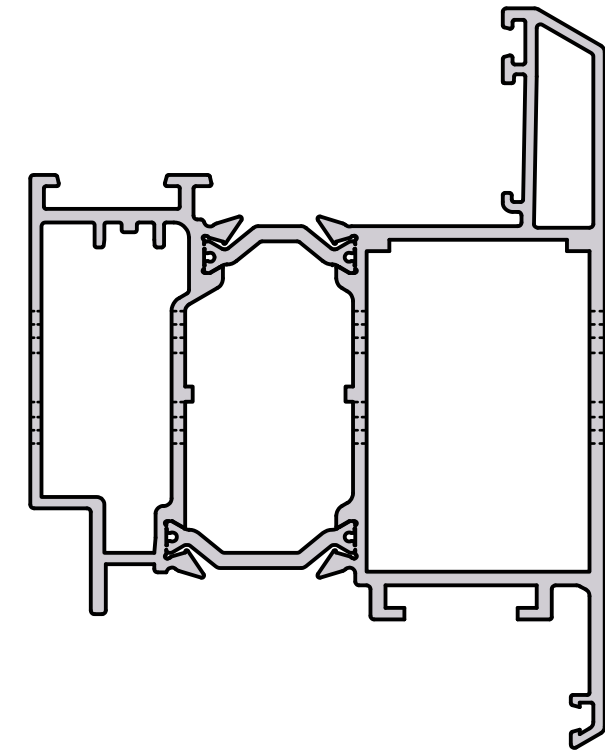
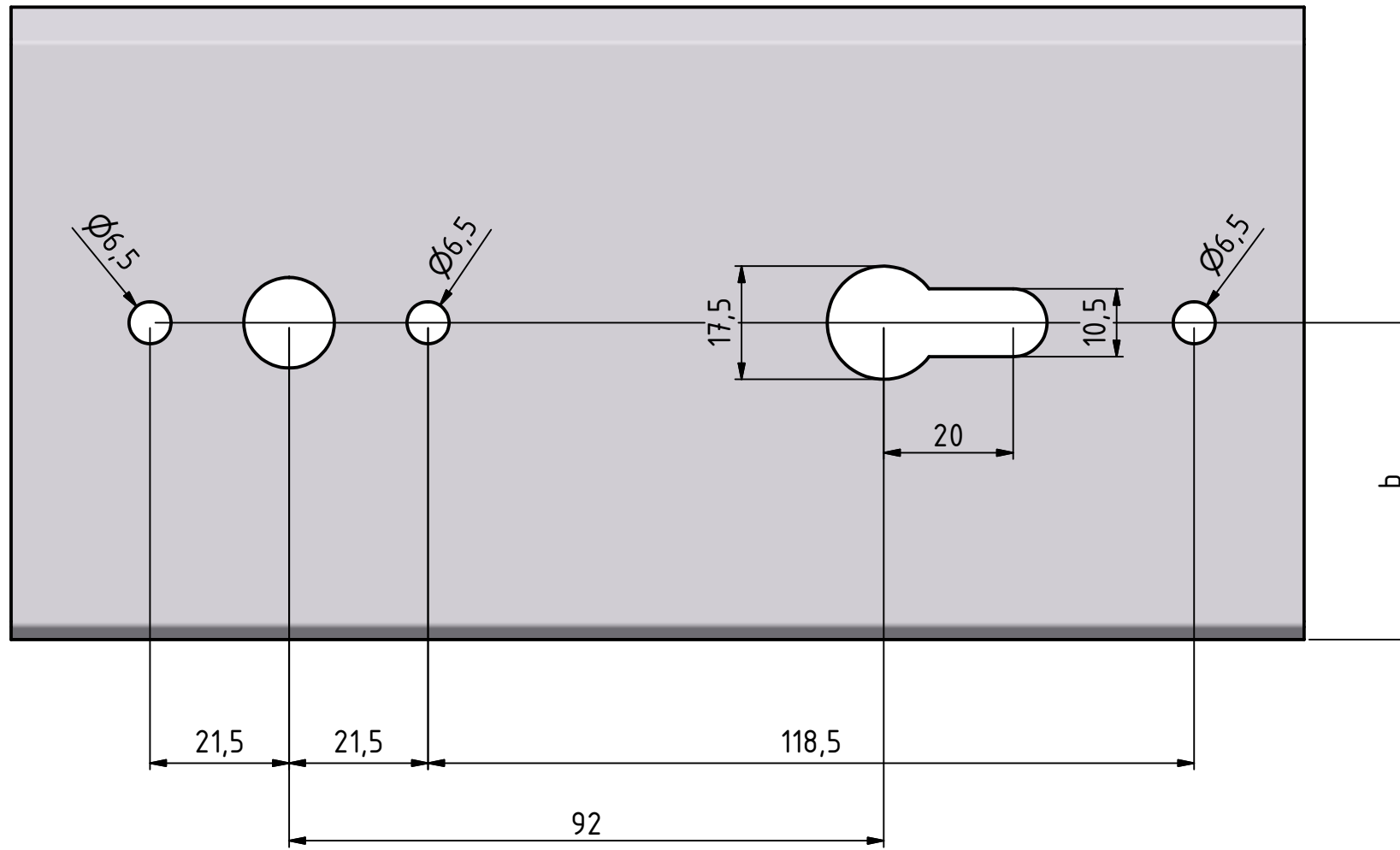

A-BS-252
A-BS-253

	P-02-205r2 b = 49
Voor	98
Pour	P-02-206 b = 54
For	103

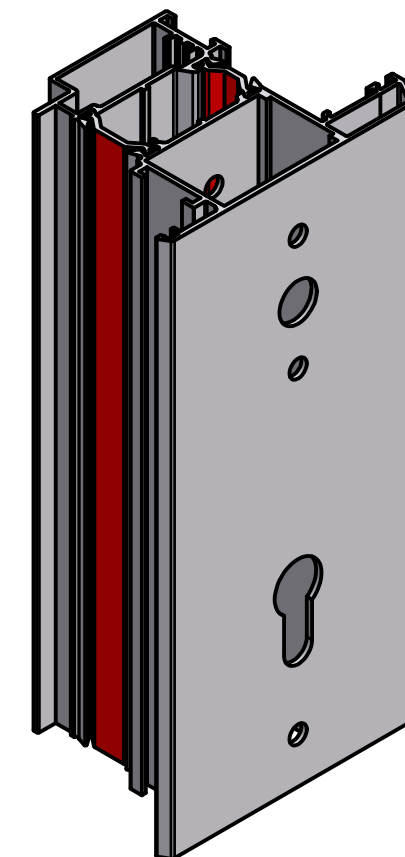

uitfrezing_deurkruk_205.idw

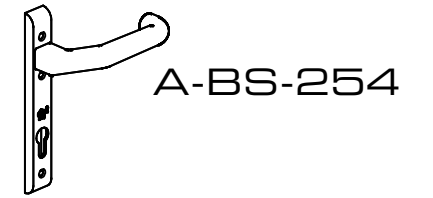
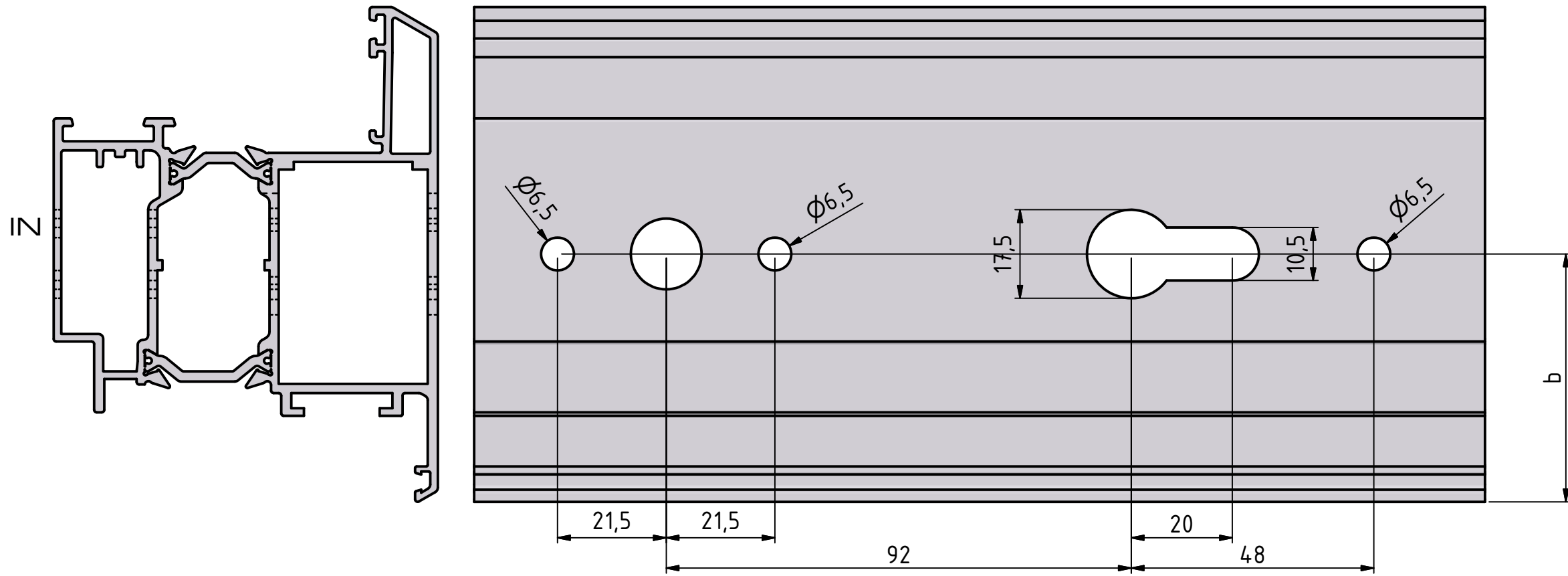

	P-02-205r2
	b = 49
Voor	98
Pour	
For	P-02-206
	b = 54
	103

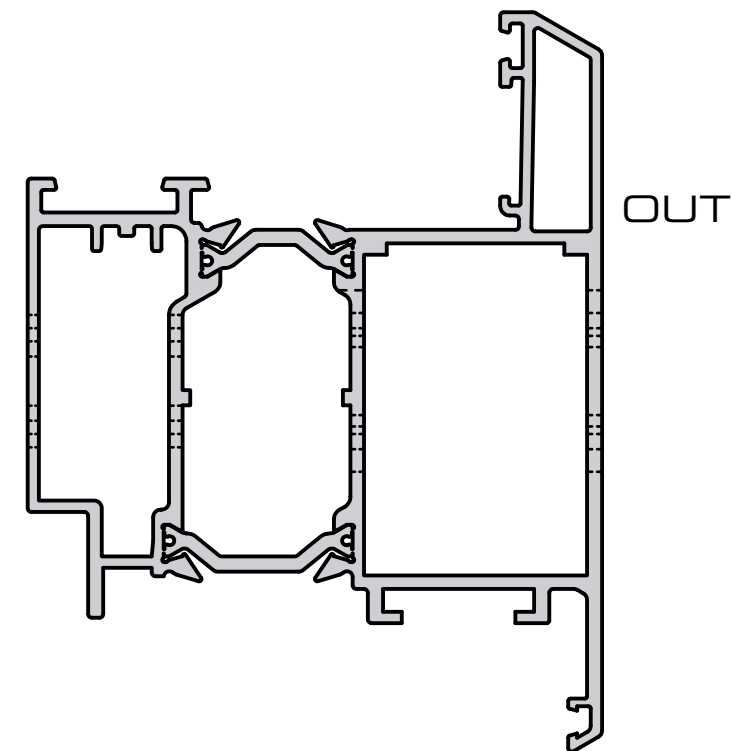
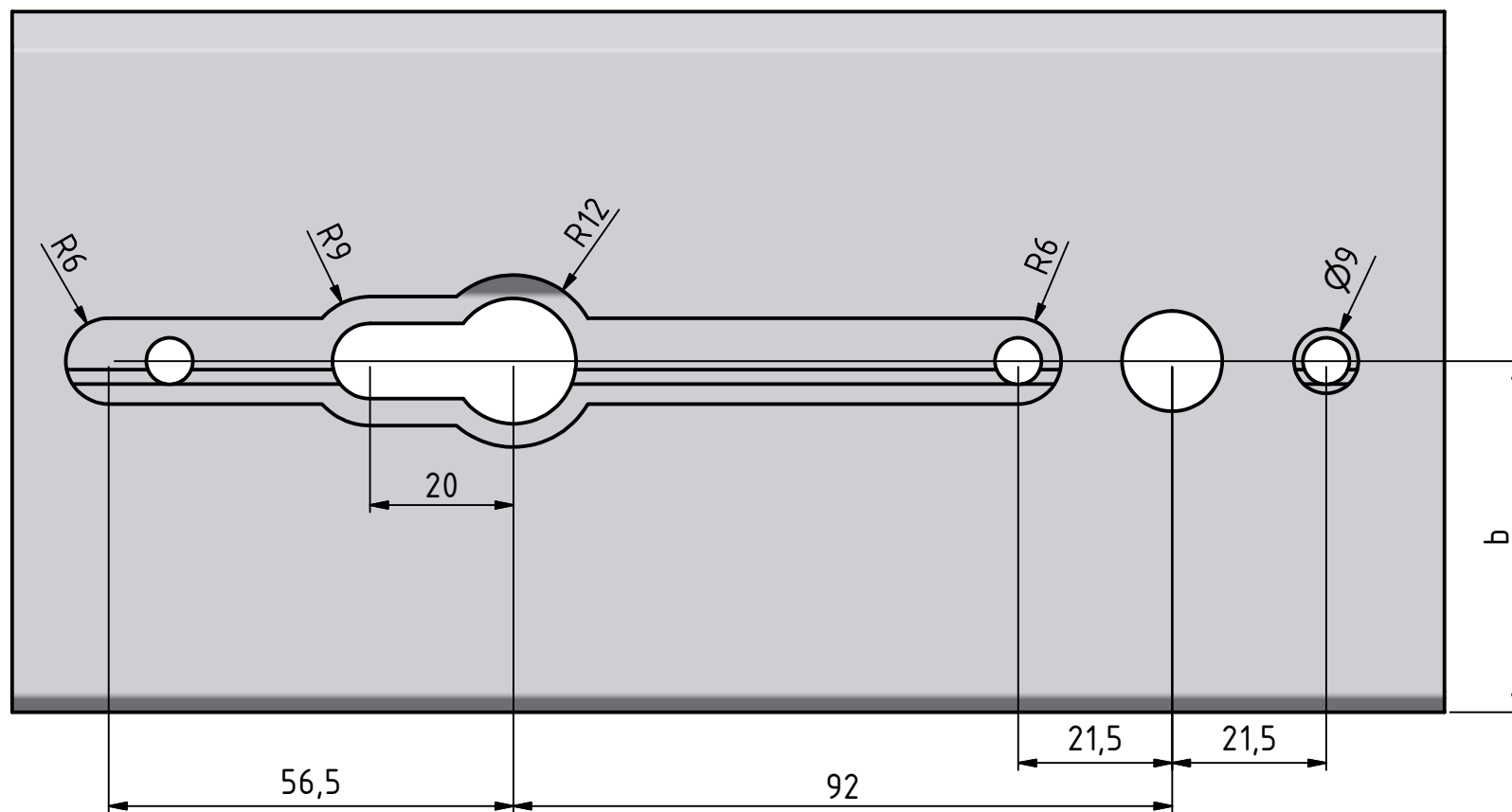

OUT

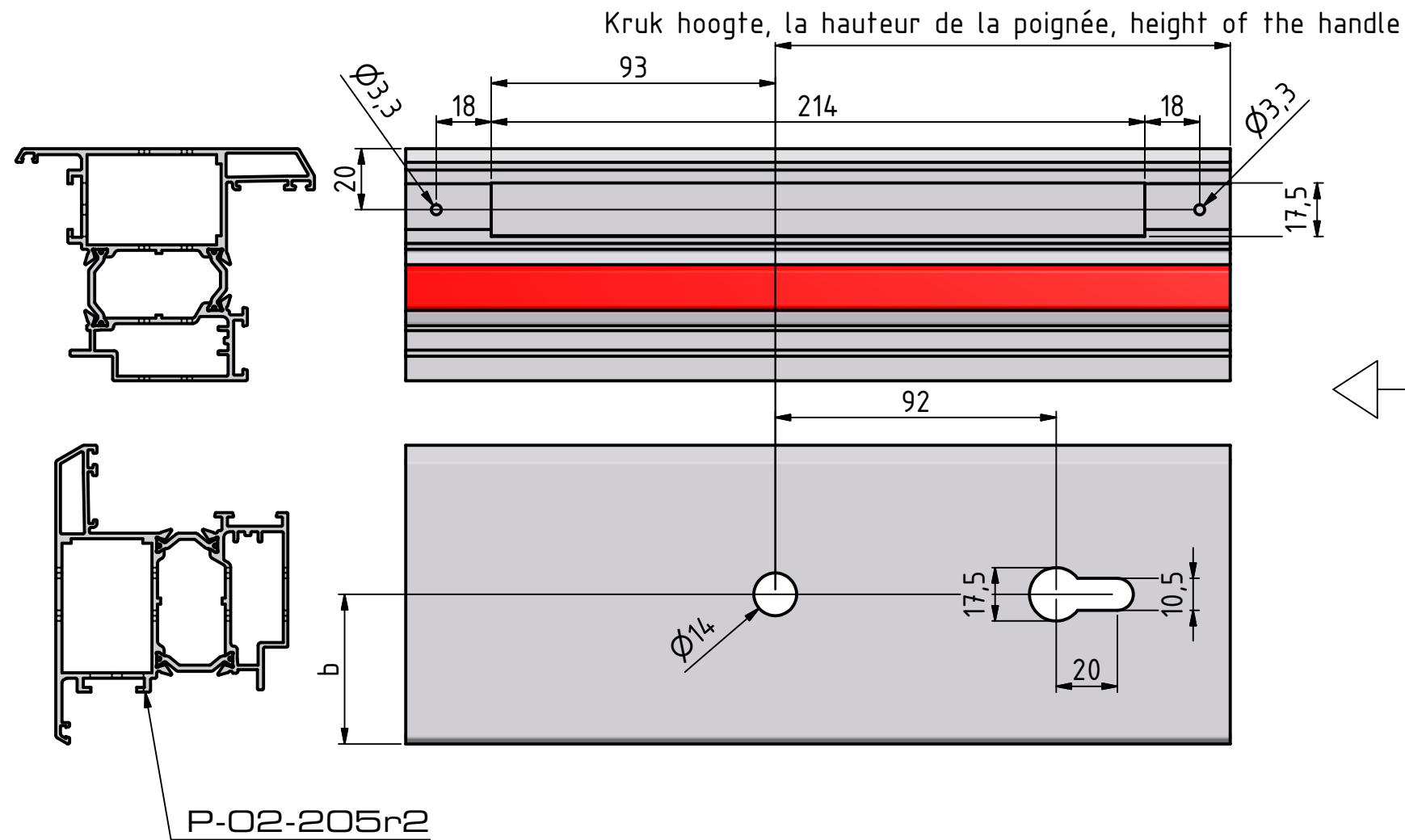

Uitfrezing
Milling
Fraisage

A-BS-240

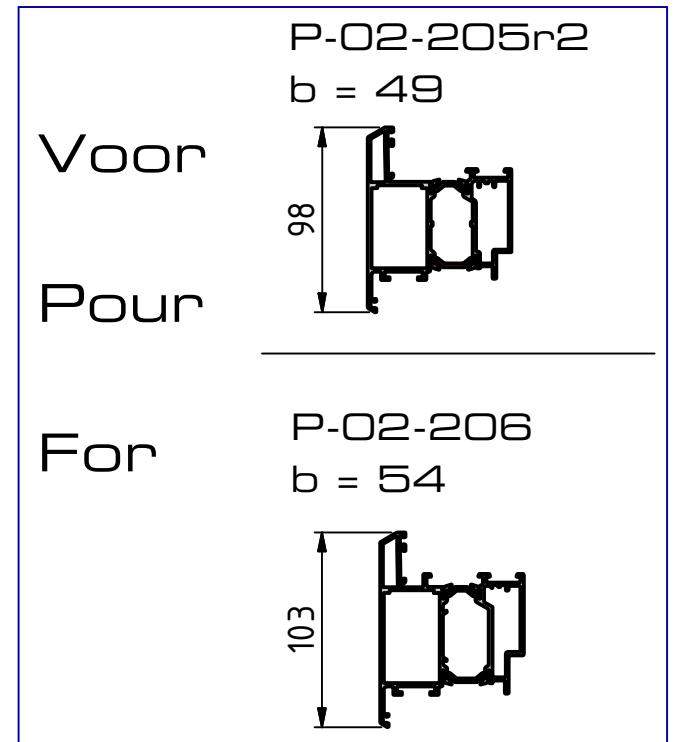

Uitfrezing
Milling
Fraisage

A-BS-241

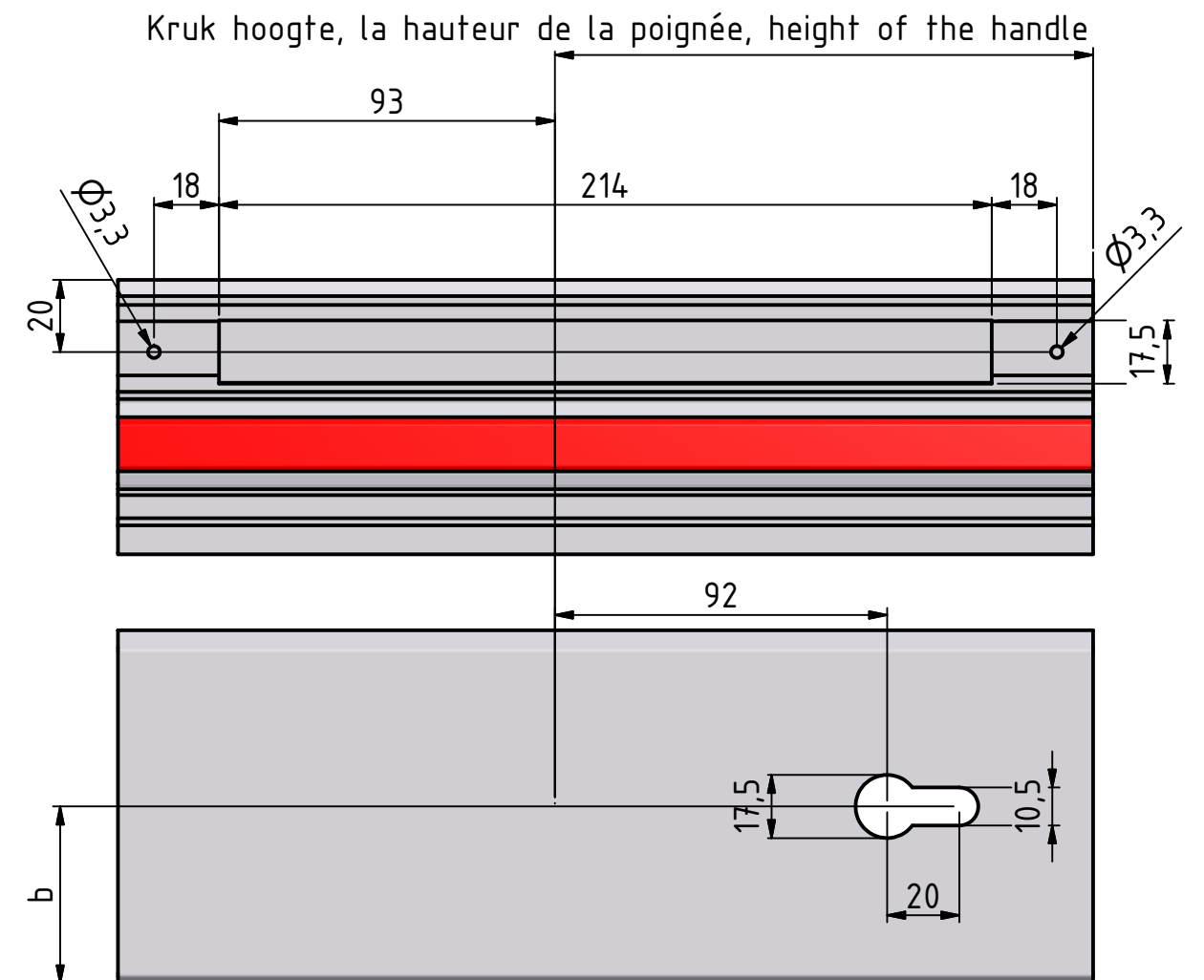



Ø7: M5x12,5
DIN 965 M5x25



Ø3,3: DIN 7982 4,2x16



Uitfrezing
Milling
Fraisage

A-BS-242
A-BS-243

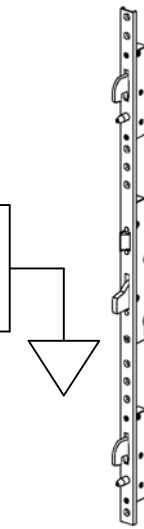

Voor
Pour
For

P-02-205r2

b = 49

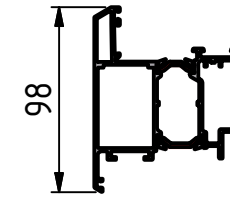

P-02-206

b = 54

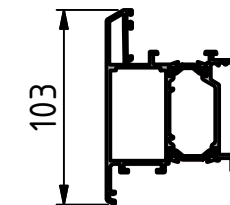

Kruk hoogte vanaf vloerpas, min 1077 mm
la hauteur de la poignée a partir du sol, min 1077 mm
height of the handle from the floor, min 1077 mm

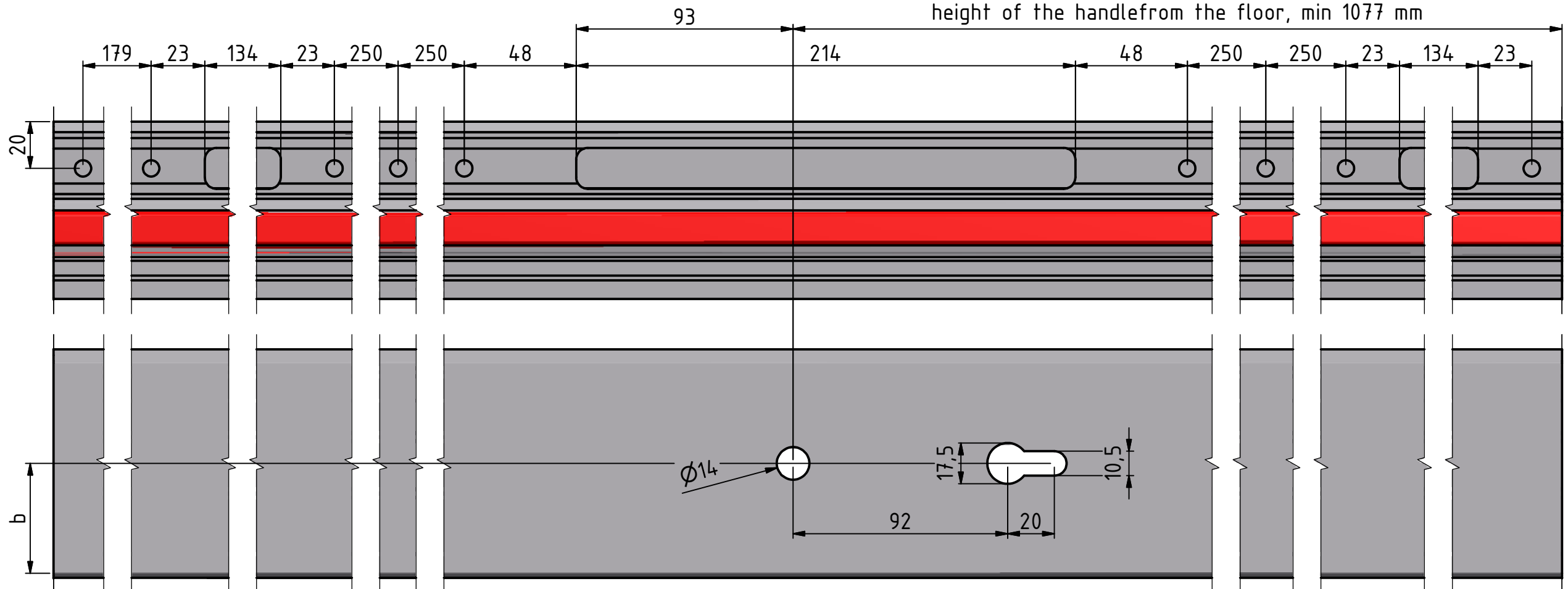
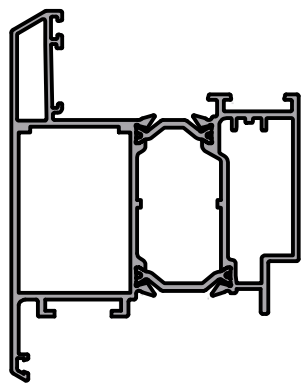
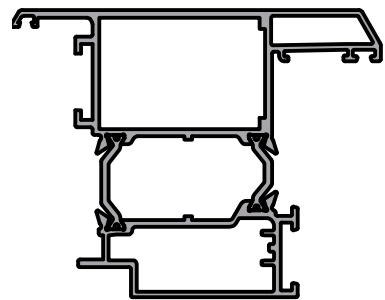

Uitfrezingslot_205.idw

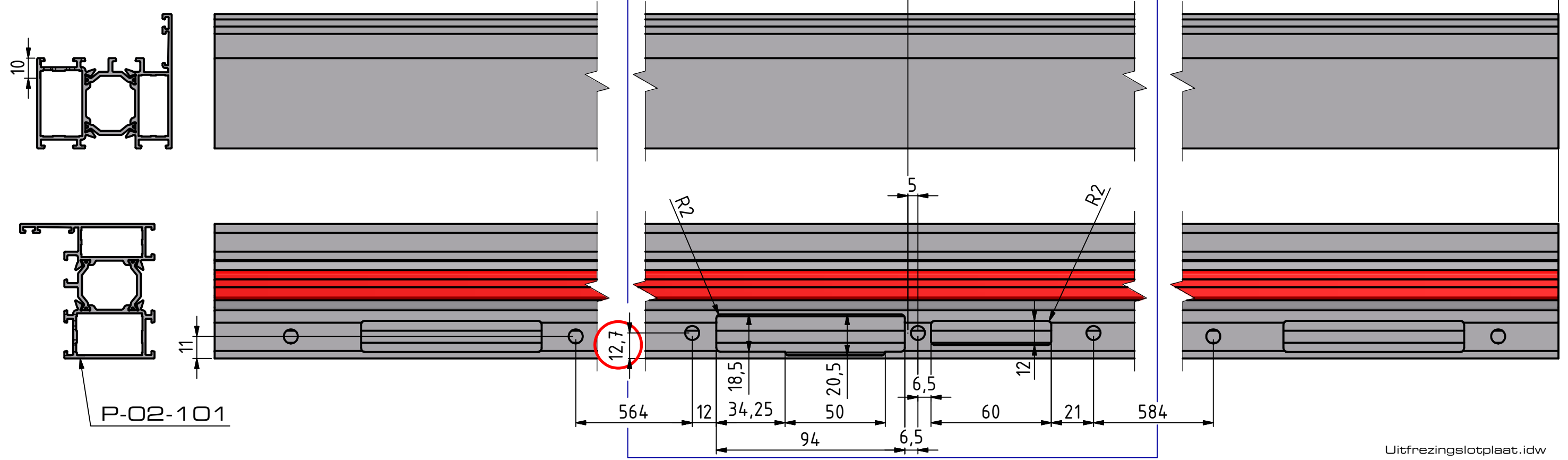
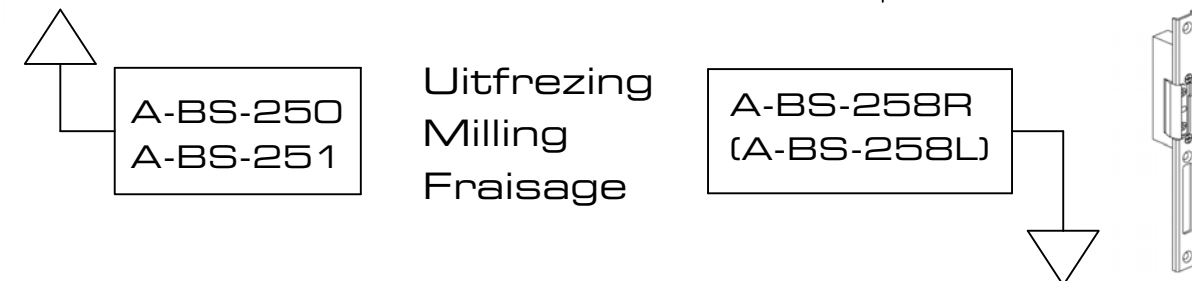
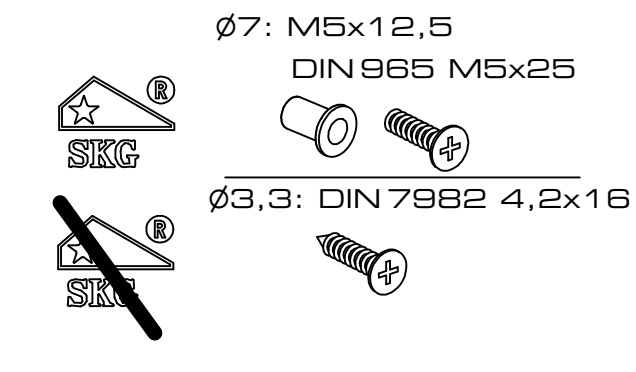
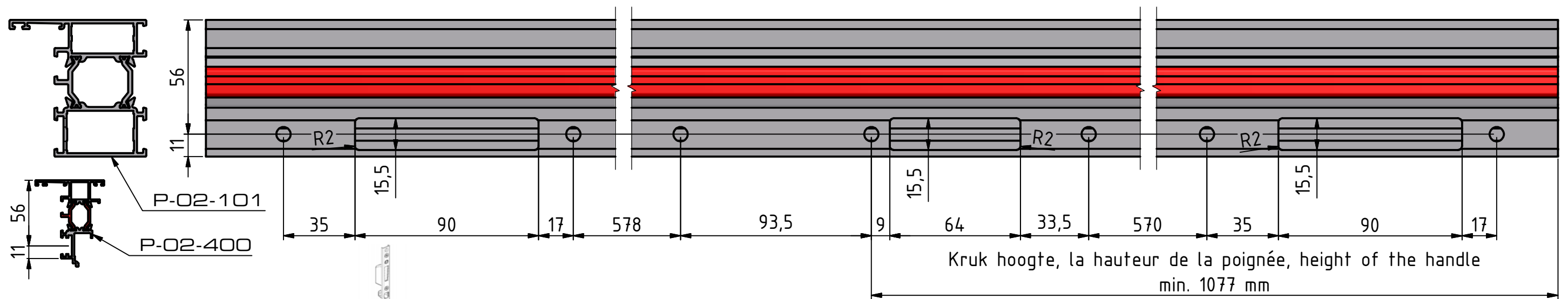

Litfrezingslotplaat.idw

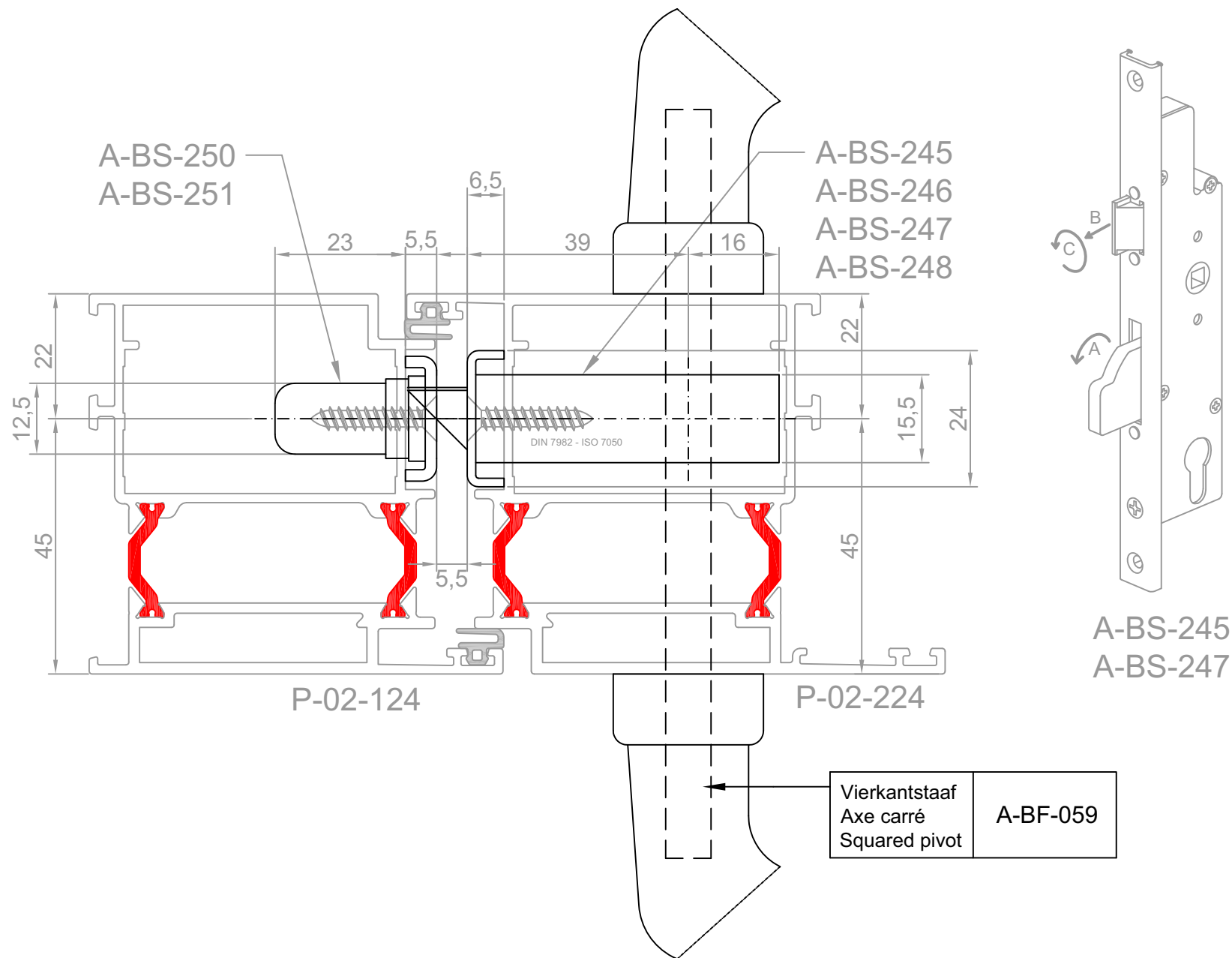

		Slottype Type serrure Locktype	Slotplaat (elektrisch) Gache (électrique) Lockplate (electric)
Penslot Serrure à pêne Lock with pen	1-punt 1-point 1-point	A-BS-245	A-BS-250 (A-BS-258L/R)
	5-punt 5-point 5-point	A-BS-247	A-BS-250 (A-BS-258L/R) A-BS-251 (2x)
Rolslot Serrure à rouleau Lock with roll	1-punt 1-point 1-point	A-BS-246	A-BS-250
	5-punt 5-point 5-point	A-BS-248	A-BS-250 A-BS-251 (2x)

		Cilinder Cylindre Cylinder	Veiligheidscil. Cyl. sécurité Safety cyl.	Cilinder 1/2 Cylindre 1/2 Cylinder 1/2
Afwerking - Finition - Finish	Zonder Sans Without	A-00-CE3045	A-00-CV3045	A-00-CE30
	Langschild Plaque longue Long plate	A-BS-252 + A-BS-253 A-BS-254 + A-BS-255	A-00-CV3560	A-00-CE35
	Cilinderplaatje Plaque de cylindre Cylinder plate	2 x A-BF-058	A-00-CV3555	A-00-CE35

Schroeven - Vis - Screws			
Langschild Plaque longue Long plate	A-BS-252 + A-BS-253		A-00-M5085 DIN 965 ISO 7046 M 5 x 85
Langschild Plaque longue Long plate	SKG A-BS-254 + A-BS-255		A-00-M6085 DIN 965 ISO 7046 M 6 x 85
Dubbele kruk + anti krukdiefstal Béquille double + anti béquille vole Dobble handle + anti handle theft	A-BF-057 + A-BF-069 (2x)		A-00-M5085 DIN 965 ISO 7046 M 5 x 85

HCdeur_vlak_binnen.dwg

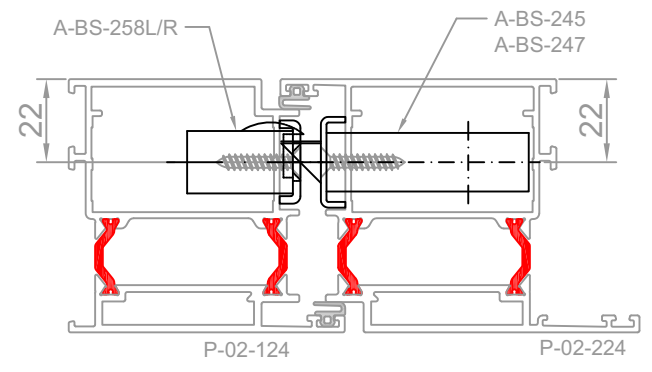
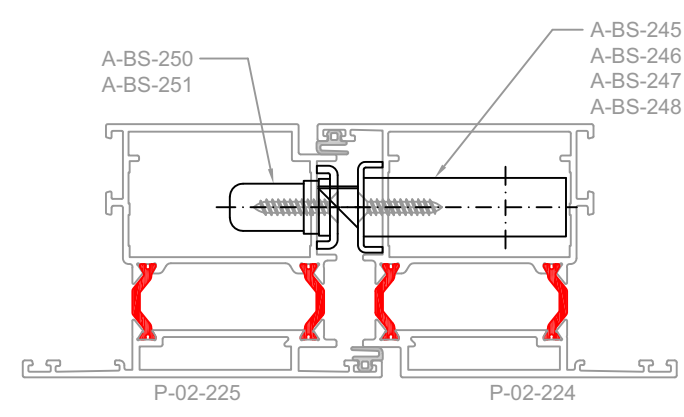

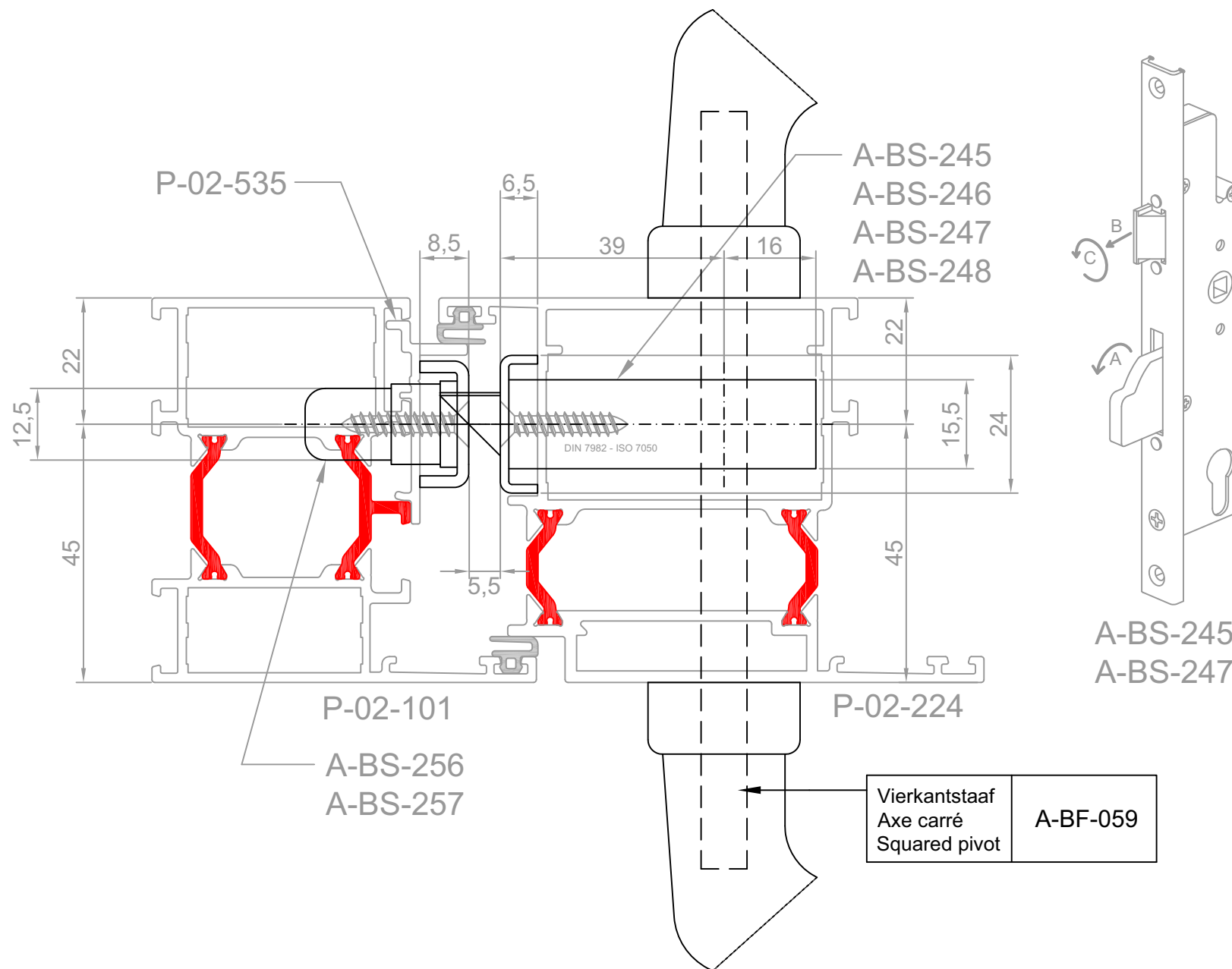

		Slottype Type serrure Locktype	Slotplaat (elektrisch) Gache (électrique) Lockplate (electric)
Penslot Serrure à pêne Lock with pen	1-punt 1-point 1-point	A-BS-245	A-BS-256 (A-BS-259L/R)
	5-punt 5-point 5-point	A-BS-247	A-BS-256 (A-BS-259L/R) A-BS-257 (2x)
Rolslot Serrure à rouleau Lock with roll	1-punt 1-point 1-point	A-BS-246	A-BS-256
	5-punt 5-point 5-point	A-BS-248	A-BS-256 A-BS-257 (2x)

		Cilinder Cylindre Cylinder	Veiligheids cil. Cyl. sécurité Safety cyl.	Cilinder 1/2 Cylindre 1/2 Cylinder 1/2	
Afwerking - Finition - Finish	Zonder Sans Without	A-00-CE3045	A-00-CV3045	A-00-CE30	
	Langschild Plaque longue Long plate	A-BS-252 + A-BS-253 A-BS-254 + A-BS-255	A-00-CE3560	A-00-CV3560	A-00-CE35
	Cilinderplaatje Plaque de cylindre Cylinder plate	2 x A-BF-058	A-00-CE3555	A-00-CV3555	A-00-CE35

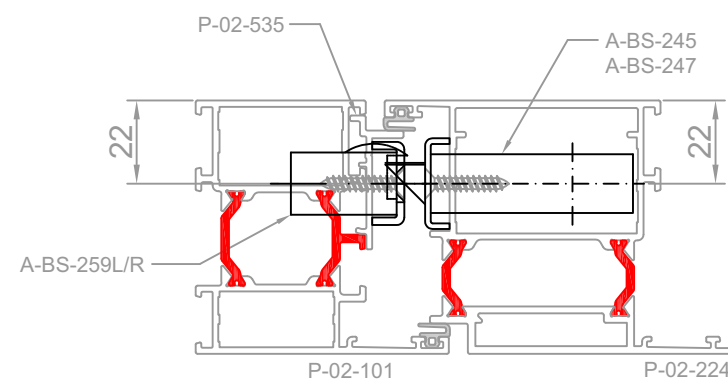
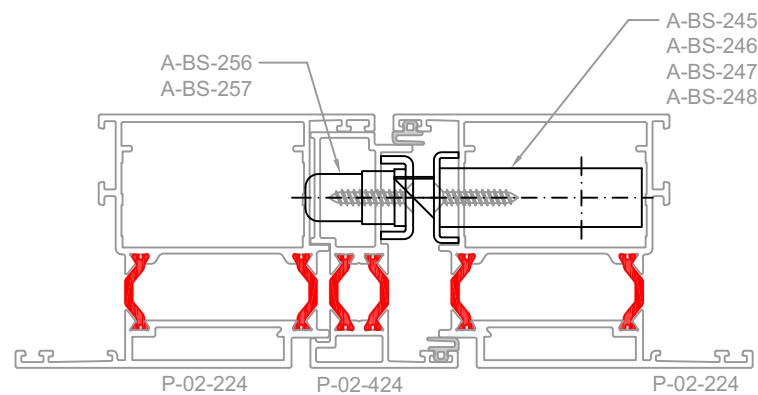

Schroeven - Vis - Screws			
Langschild Plaque longue Long plate	A-BS-252 + A-BS-253	A-00-M5085	DIN 965 ISO 7046 M 5 x 85
Langschild Plaque longue Long plate	SKG A-BS-254 + A-BS-255	A-00-M6085	DIN 965 ISO 7046 M 6 x 85
Dubbele kruk + anti krukdiefstal Béquille double + anti béquille vole Dobble handle + anti handle theft	A-BF-057 + A-BF-069 (2x)	A-00-M5085	DIN 965 ISO 7046 M 5 x 85

HCdeur_vlak_binnen_vleugel.dwg

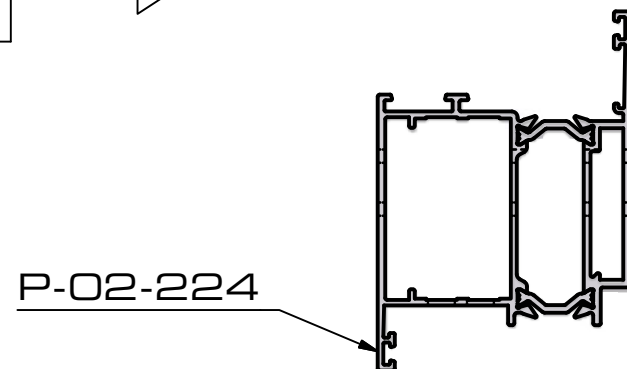
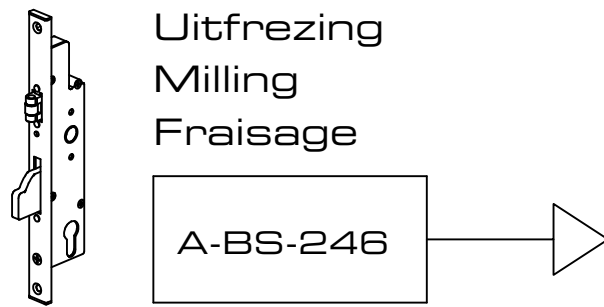
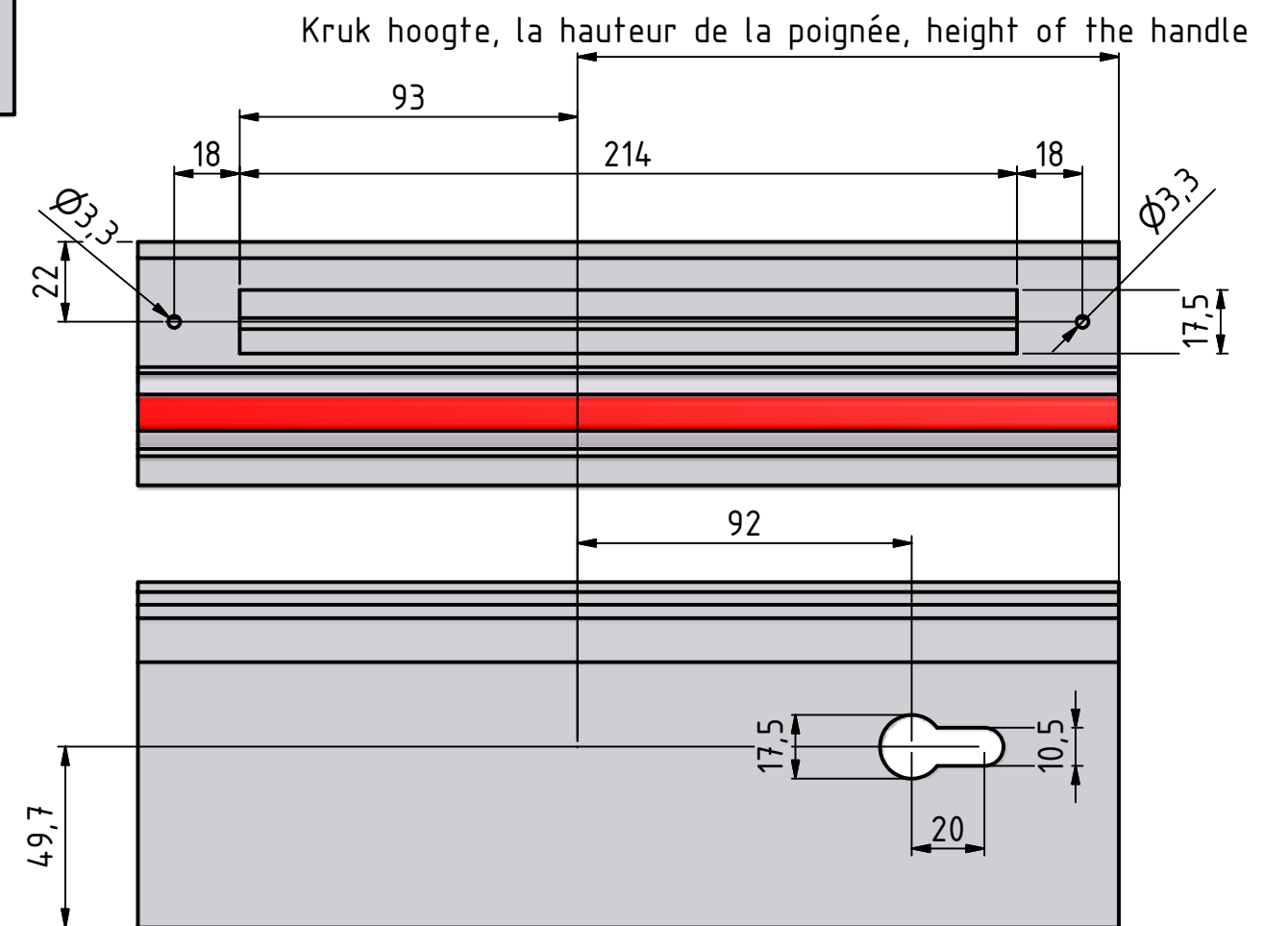
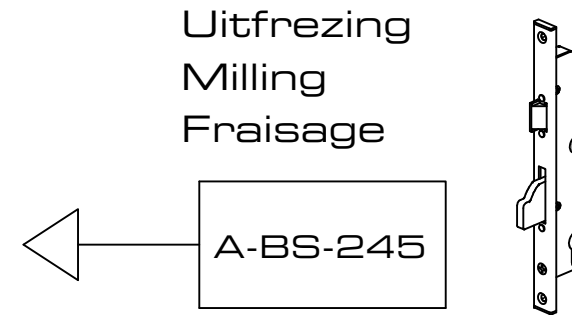
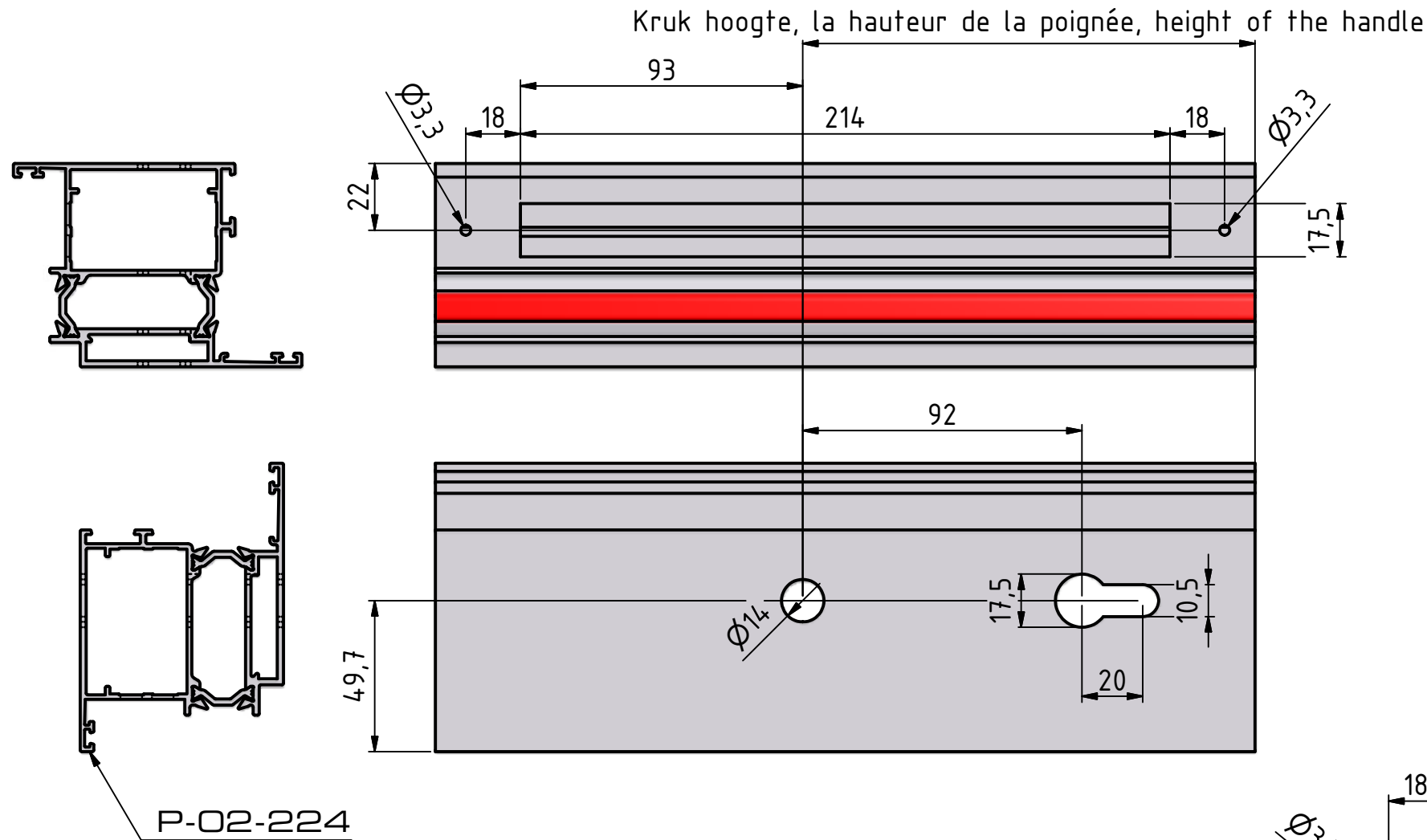

uitfrezingen/enkelvlak.idw

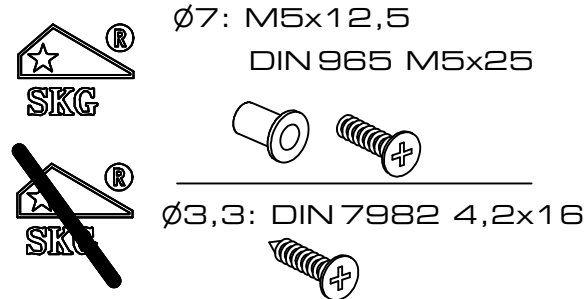

Uitfrezing
Milling
Fraisage

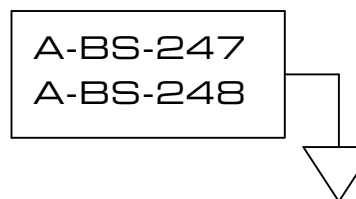

Kruk hoogte vanaf vloerpas, min 1077 mm
la hauteur de la poignée a partir du sol, min 1077 mm
height of the handle from the floor, min 1077 mm

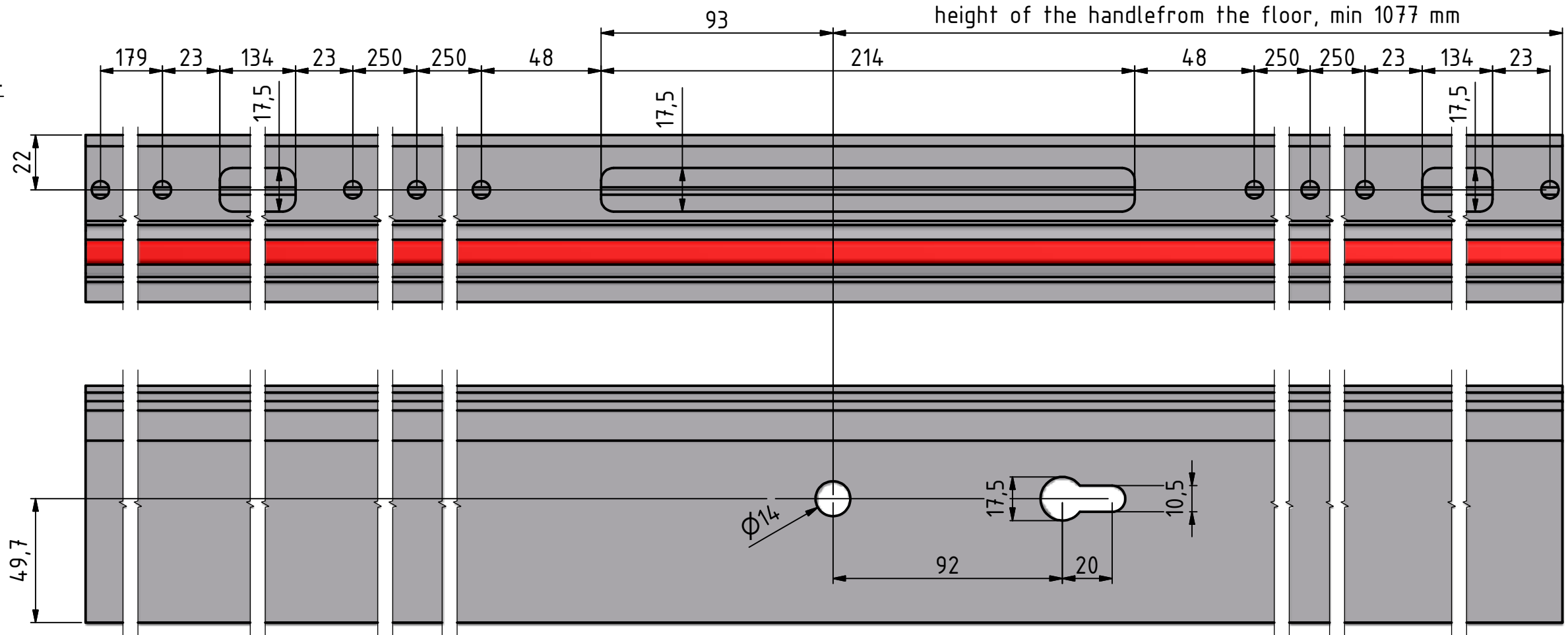
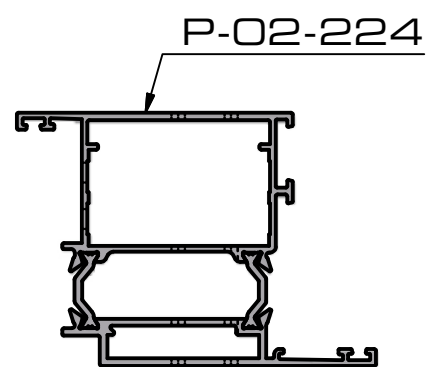

Uitfrezingslotvlak.idw

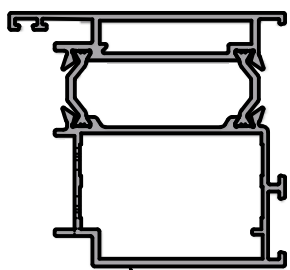
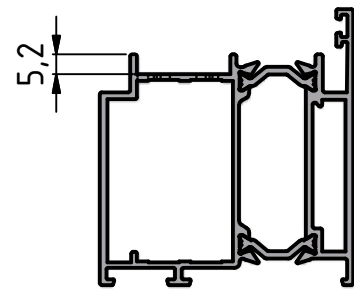
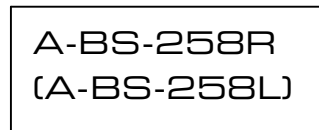
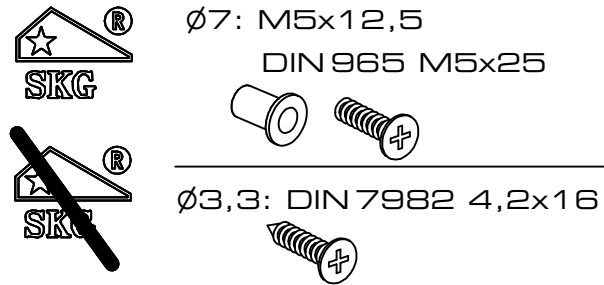
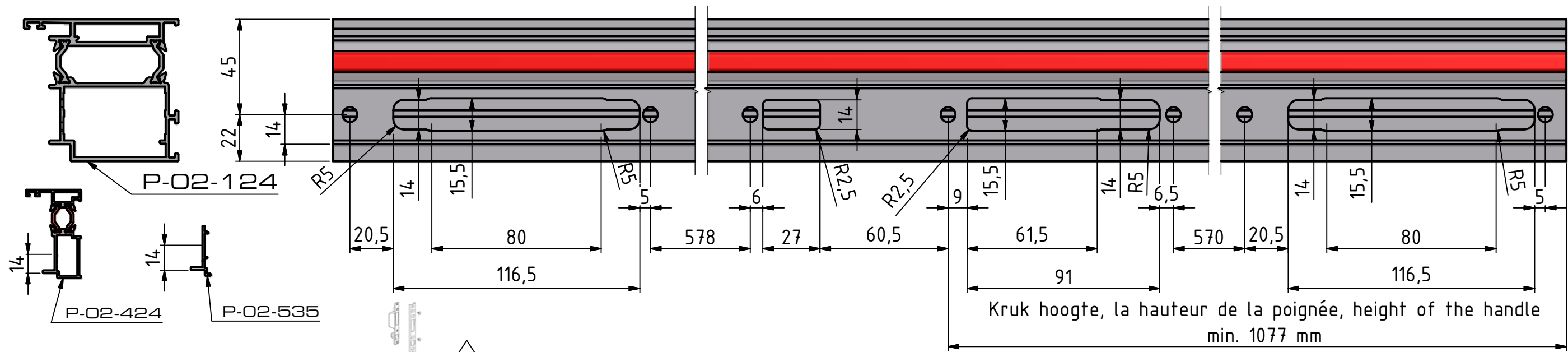

P-02-124

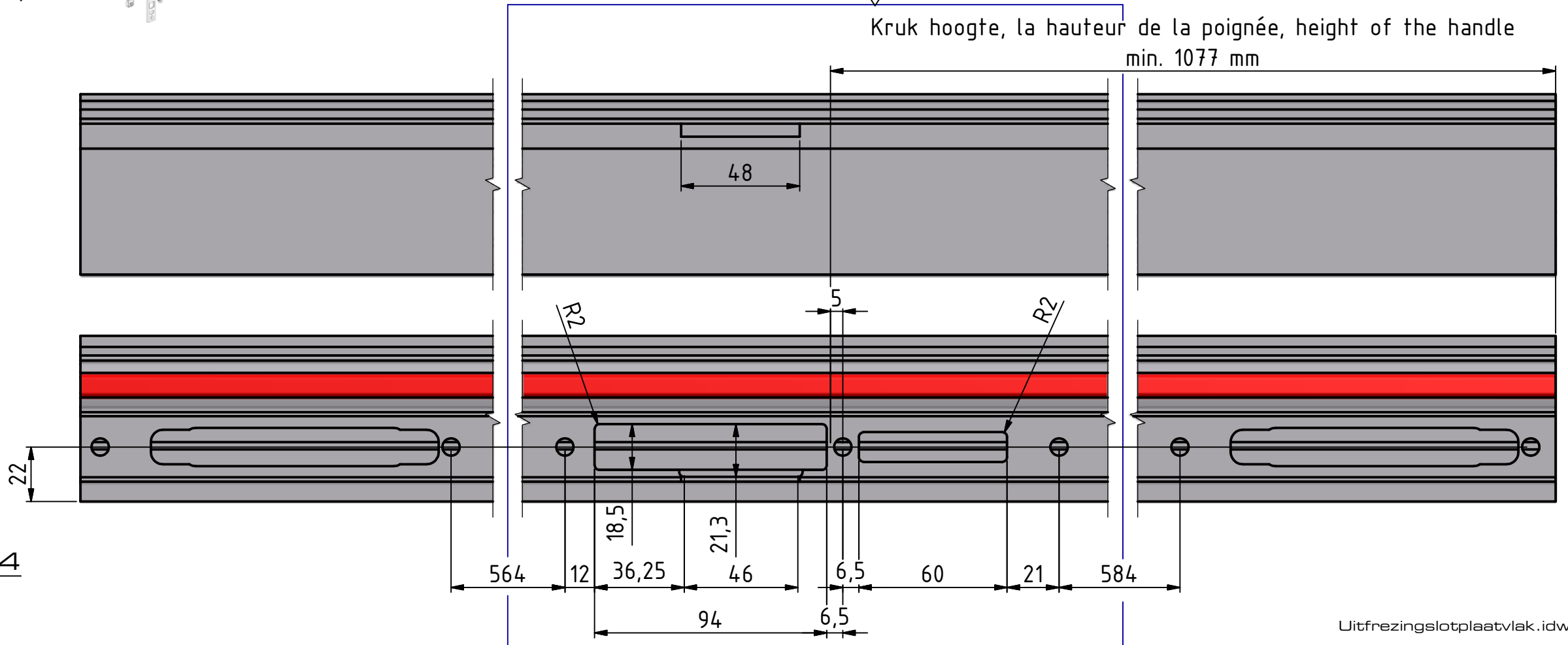

Uitfrezingslotplaatvlak.idw

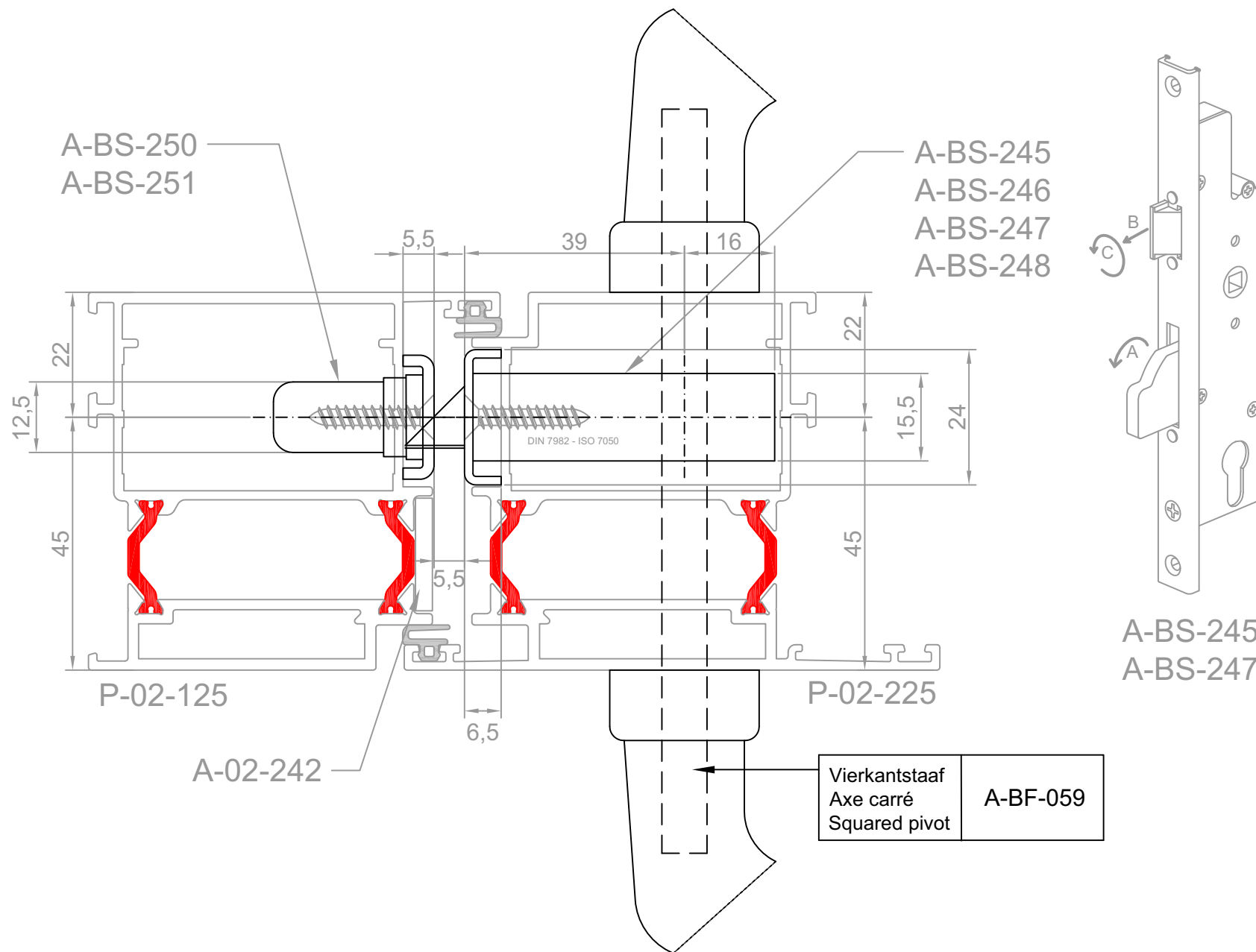

		Slottype Type serrure Locktype	Slotplaat (elektrisch) Gache (électrique) Lockplate (electric)
Penslot Serrure à pêne Lock with pen	1-punt 1-point 1-point	A-BS-245	A-BS-250 (A-BS-258L/R)
	5-punt 5-point 5-point	A-BS-247	A-BS-250 (A-BS-258L/R) A-BS-251 (2x)
Rolslot Serrure à rouleau Lock with roll	1-punt 1-point 1-point	A-BS-246	A-BS-250
	5-punt 5-point 5-point	A-BS-248	A-BS-250 A-BS-251 (2x)

		Cilinder Cylindre Cylinder	Veiligheids cil. Cyl. sécurité Safety cyl.	Cilinder 1/2 Cylindre 1/2 Cylinder 1/2
Afwerking - Finition - Finish	Zonder Sans Without	A-00-CE3045	A-00-CV3045	A-00-CE30
	Langschild Plaque longue Long plate	A-00-CE3560	A-00-CV3560	A-00-CE35
	Cilinderplaatje Plaque de cylindre Cylinder plate 2 x A-BF-058	A-00-CE3555	A-00-CV3555	A-00-CE35

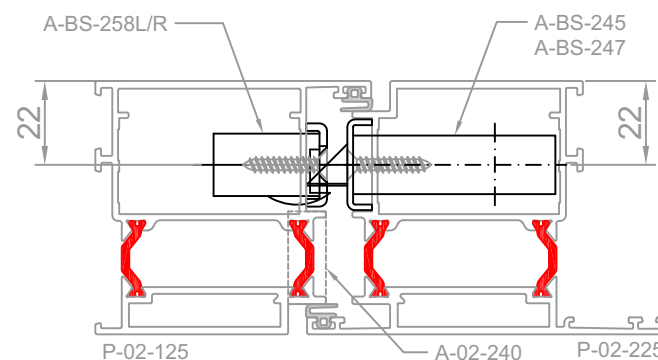
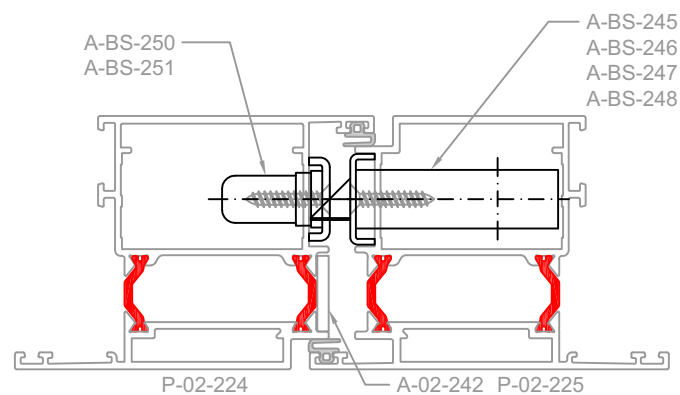

Schroeven - Vis - Screws			
Langschild Plaque longue Long plate	A-BS-252 + A-BS-253	A-00-M5085	DIN 965 ISO 7046 M 5 x 85
Langschild Plaque longue Long plate	SKG A-BS-254 + A-BS-255	A-00-M6085	DIN 965 ISO 7046 M 6 x 85
Dubbele kruk + anti krukdiefstal Béquille double + anti béquille vole Dobble handle + anti handle theft	A-BF-057 + A-BF-069 (2x)	A-00-M5085	DIN 965 ISO 7046 M 5 x 85

HCdeur_vlak_buiten.dwg

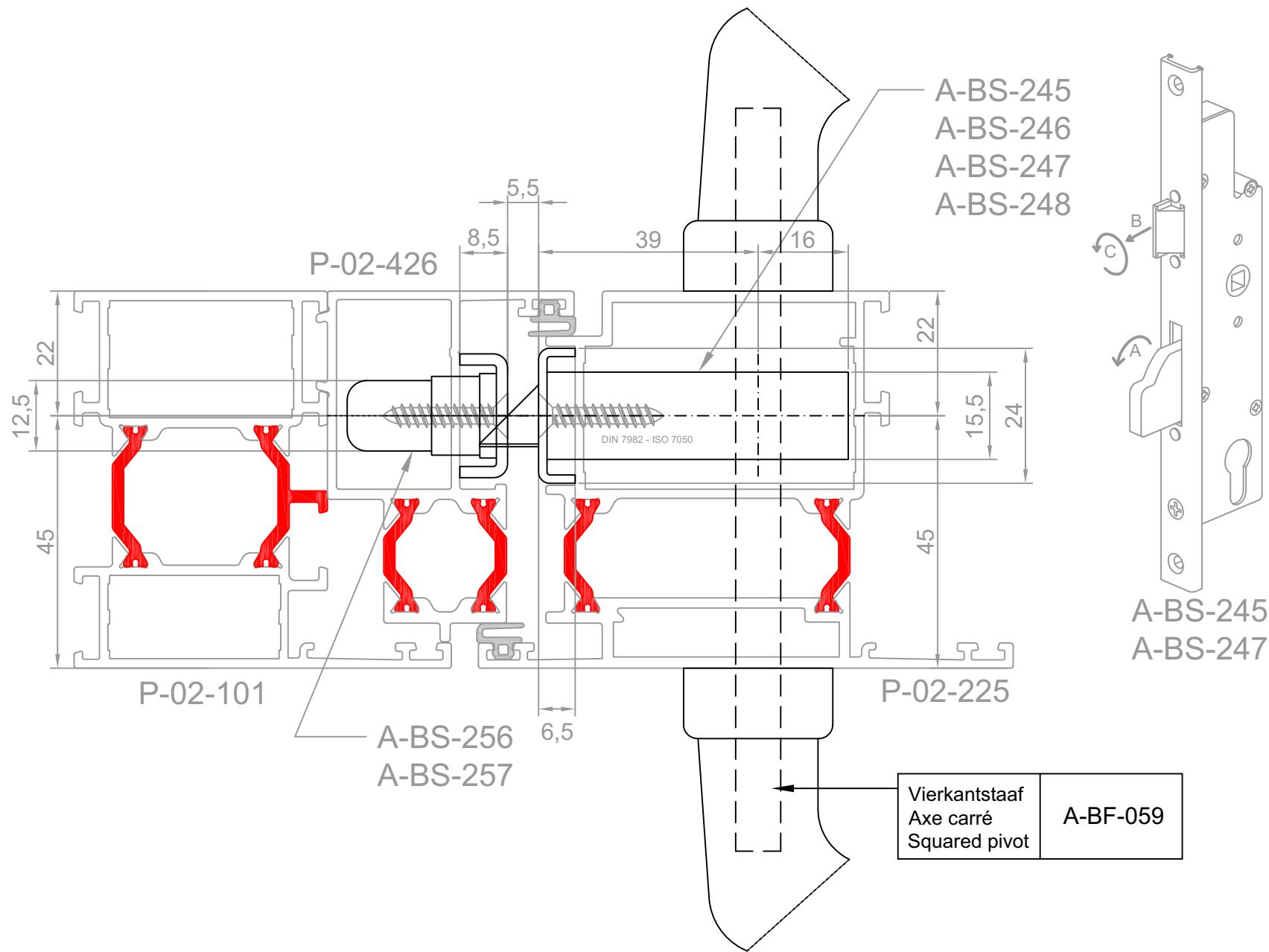

		Slottype Type serrure Locktype	Slotplaat (elektrisch) Gache (électrique) Lockplate (electric)
Penslot Serrure à pêne Lock with pen	1-punt 1-point 1-point	A-BS-245	A-BS-256 (A-BS-259L/R)
	5-punt 5-point 5-point	A-BS-247	A-BS-256 (A-BS-259L/R) A-BS-257 (2x)
Rolslot Serrure à rouleau Lock with roll	1-punt 1-point 1-point	A-BS-246	A-BS-256
	5-punt 5-point 5-point	A-BS-248	A-BS-256 A-BS-257 (2x)

		Cilinder Cylindre Cylinder	Veiligheidscil. Cyl. sécurité Safety cyl.	Cilinder 1/2 Cylindre 1/2 Cylinder 1/2	
Afwerking - Finition - Finish	Zonder Sans Without	A-00-CE3045	A-00-CV3045	A-00-CE30	
	Langschild Plaque longue Long plate	A-BS-252 + A-BS-253 A-BS-254 + A-BS-255	A-00-CE3560	A-00-CV3560	A-00-CE35
	Cilinderplaatje Plaque de cylindre Cylinder plate 2 x A-BF-058	A-00-CE3555	A-00-CV3555	A-00-CE35	

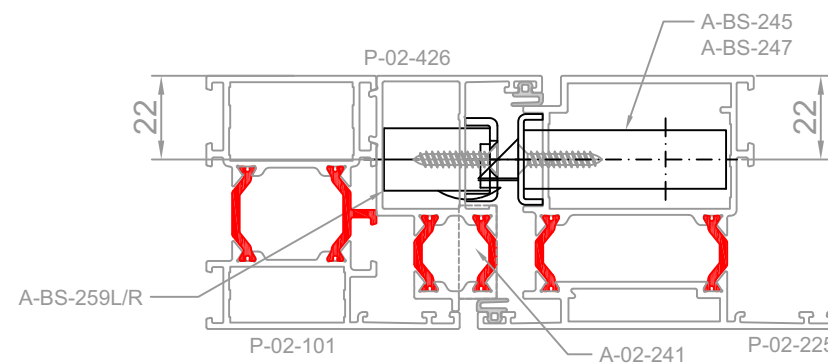
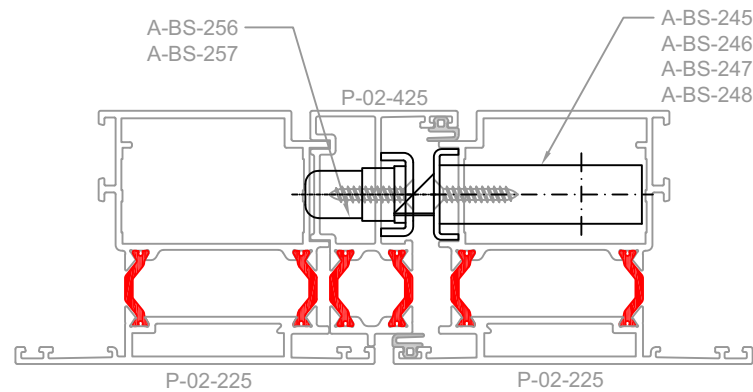

Schroeven - Vis - Screws			
Langschild Plaque longue Long plate	A-BS-252 + A-BS-253	A-00-M5085	DIN 965 ISO 7046 M 5 x 85
Langschild Plaque longue Long plate	SKG A-BS-254 + A-BS-255	A-00-M6085	DIN 965 ISO 7046 M 6 x 85
Dubbele kruk + anti krukdiefstal Béquille double + anti béquille vole Dobble handle + anti handle theft	A-BF-057 + A-BF-069 (2x)	A-00-M5085	DIN 965 ISO 7046 M 5 x 85

HCdeur_vlak_buiten_vleugel.dwg

Kruk hoogte, la hauteur de la poignée, height of the handle

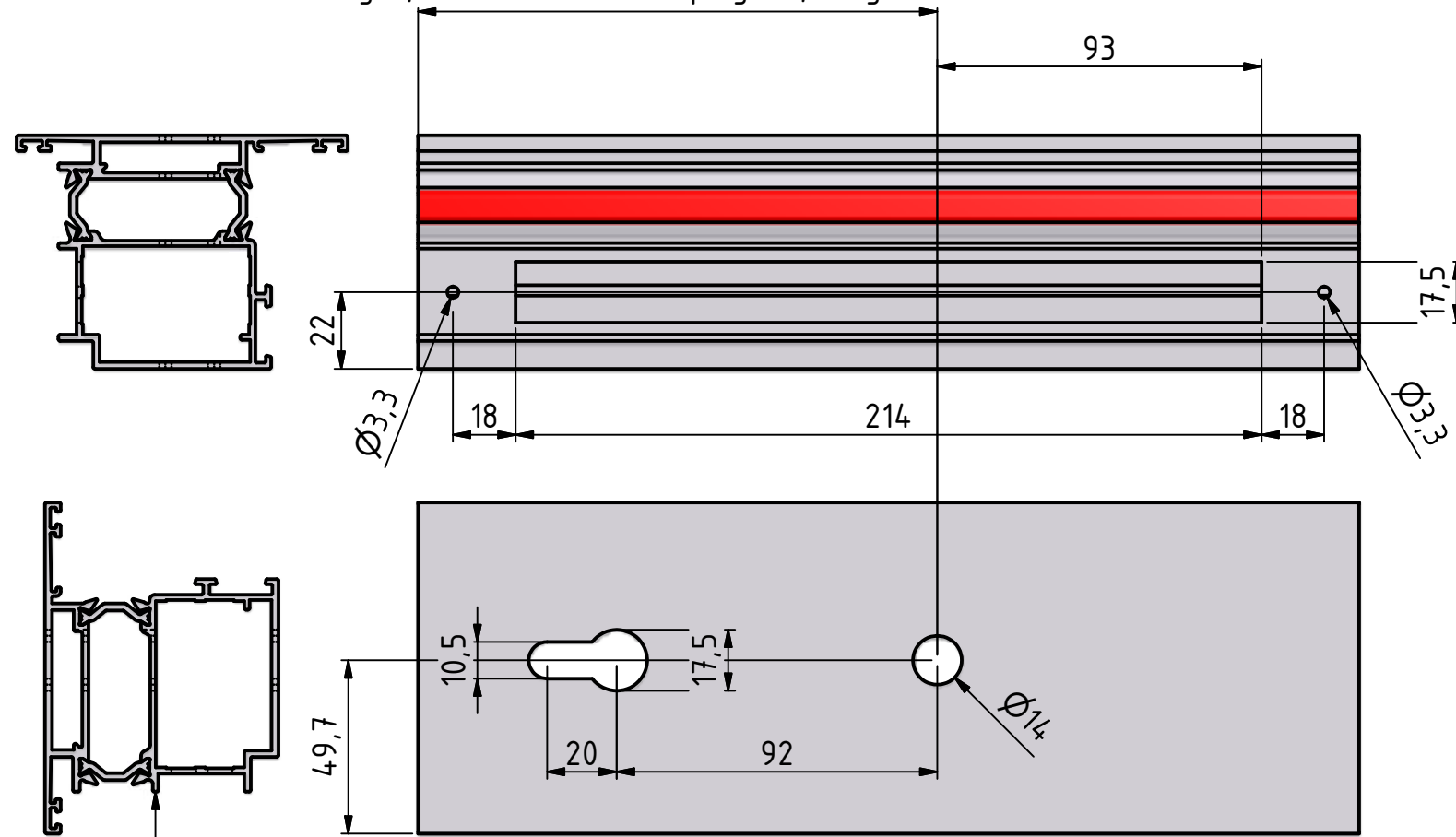

Uitfrezing
Milling
Fraisage

A-BS-245

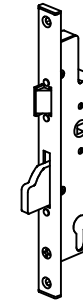

P-02-225

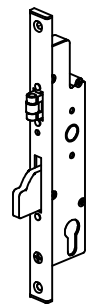

Uitfrezing
Milling
Fraisage

A-BS-246

P-02-225

Kruk hoogte, la hauteur de la poignée, height of the handle

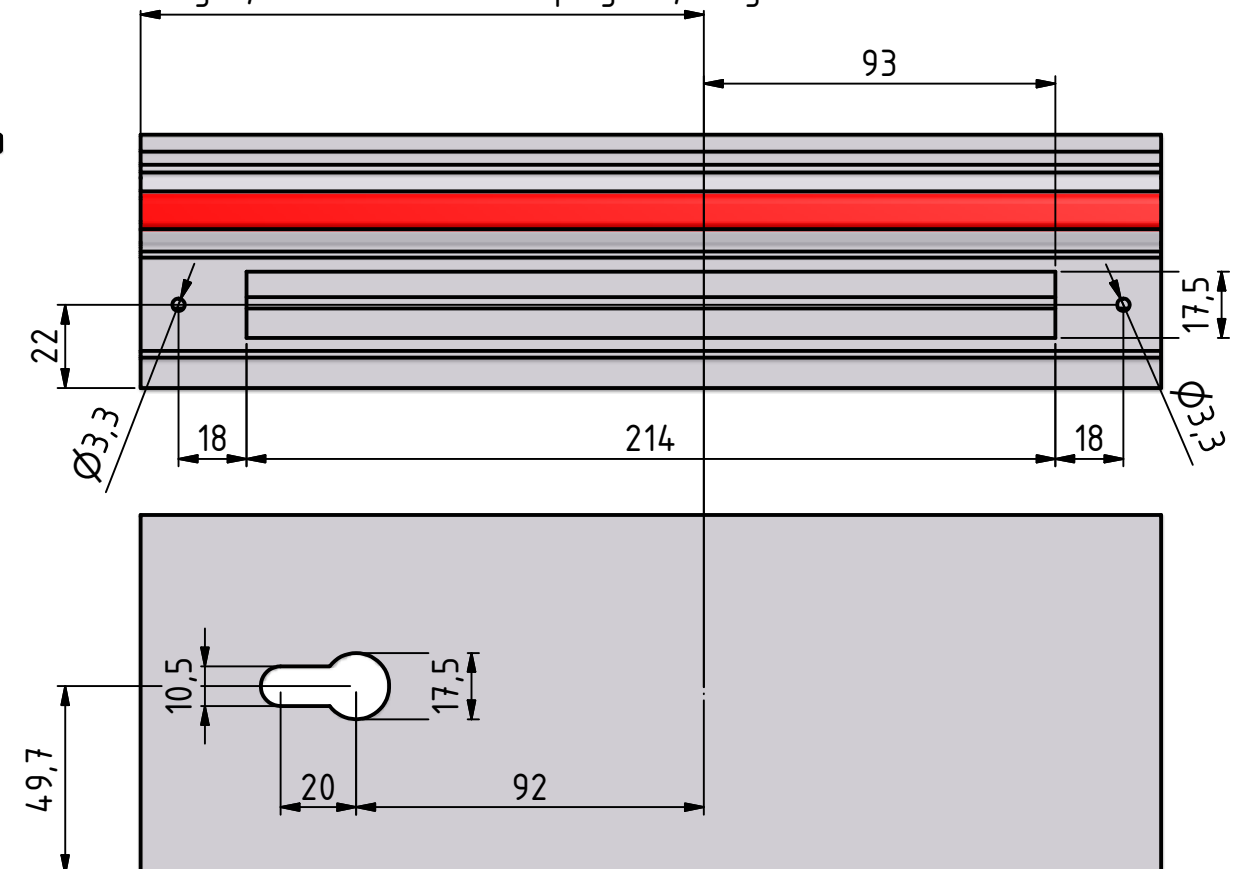

uitfrezingenkelvlak_225.idw

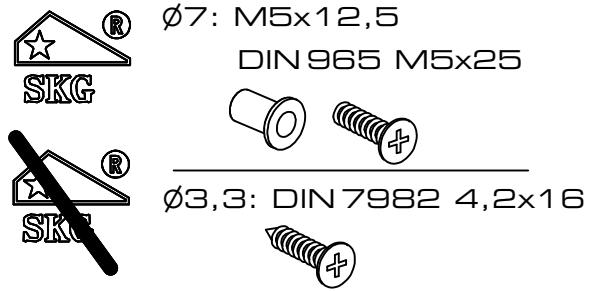

Uitfrezing
 Milling
 Fraisage

A-BS-247
 A-BS-248



Kruk hoogte vanaf vloerpas, min 1077 mm
 la hauteur de la poignée a partir du sol, min 1077 mm
 height of the handle from the floor, min 1077 mm

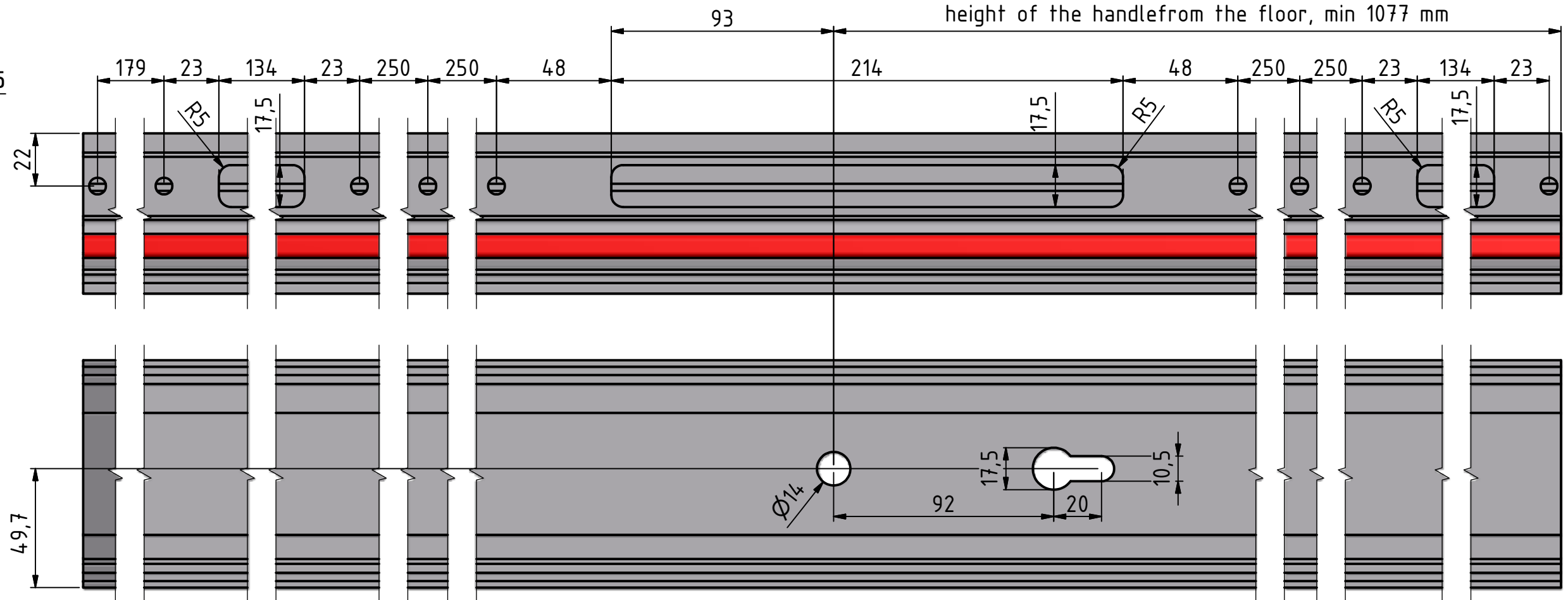
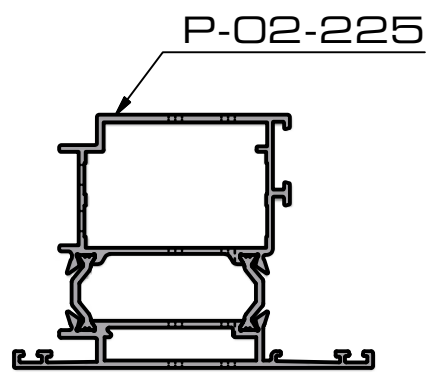

Uitfrezingslotvlak_225.idw

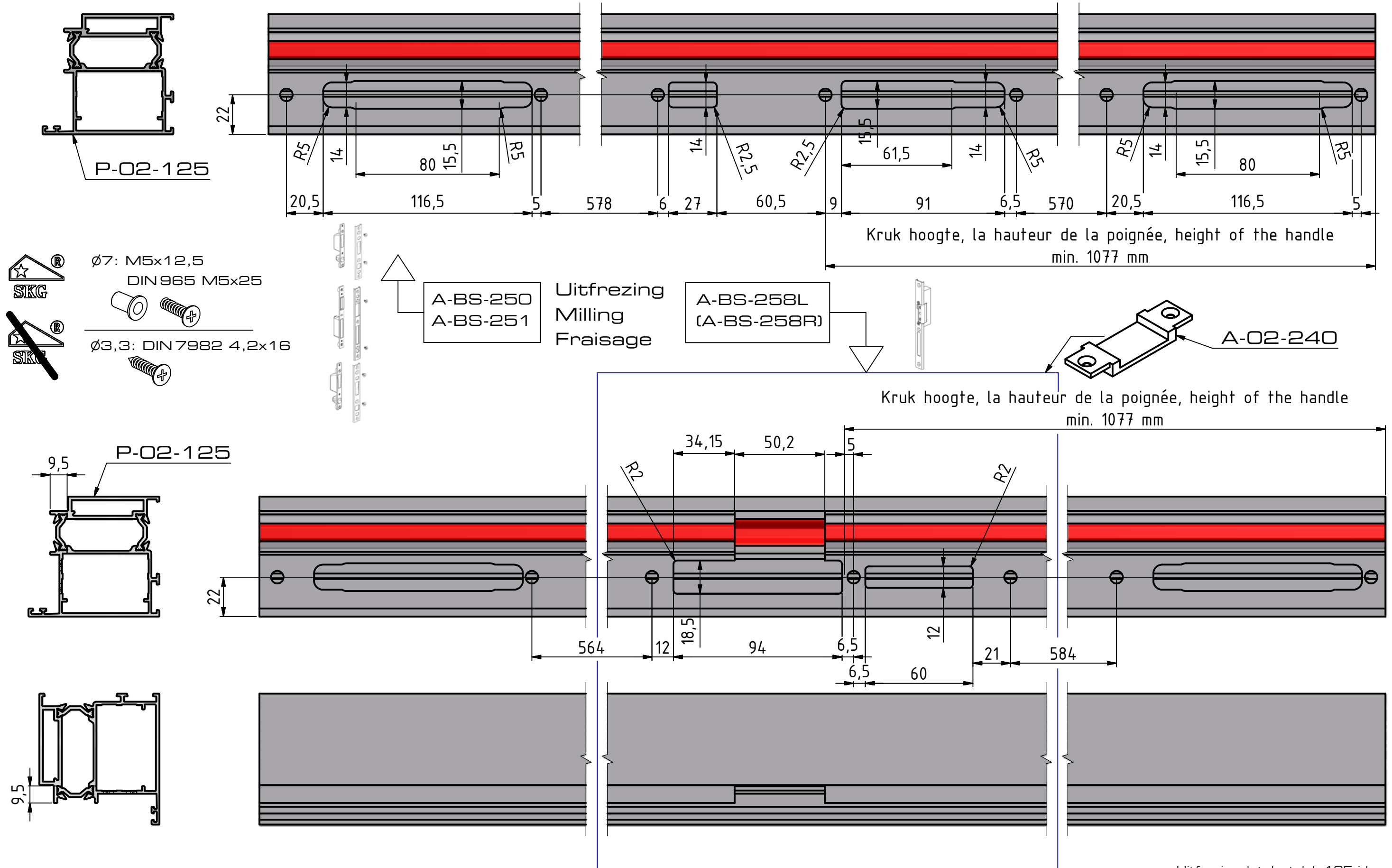

Uitfrezingslotplaatvlak_125.idw

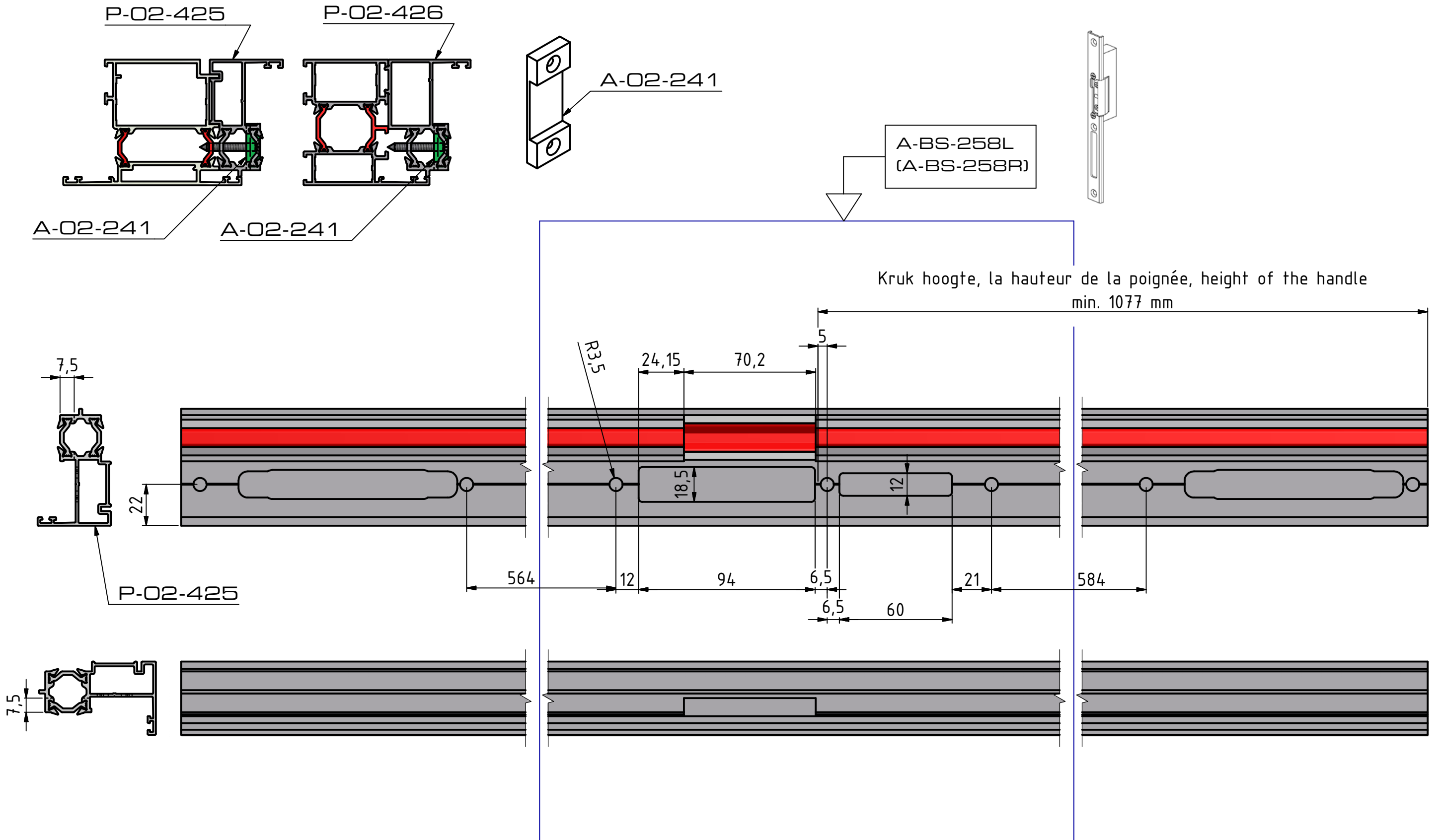

Litfrezingslotplaatvlak_425.idw